

# Wimbledon AX3/5 BLOCK DIAGRAM

PCB STACK UP  
6L UMA CO-LAY DIS

- LAYER 1 : TOP
- LAYER 2 : SGND
- LAYER 3 : IN1
- LAYER 4 : IN2
- LAYER 5 : VCC
- LAYER 6 : BOT

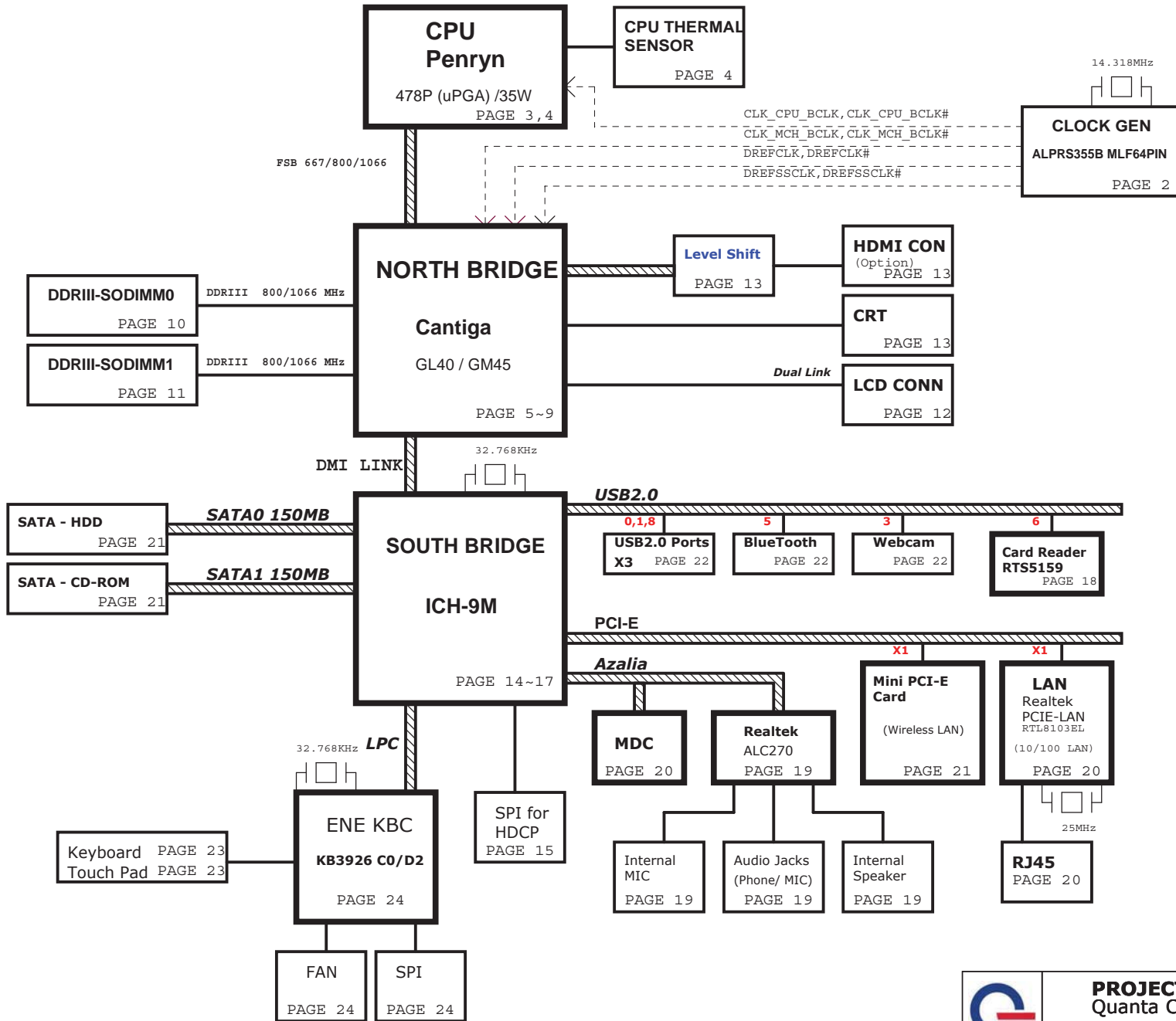

- SYSTEM CHARGER (ISL6251AHAZ-T) PAGE 25
- SYSTEM POWER (RT8206BGQW) PAGE 26
- VCCP +1.05V (RT8209AGQW) & +1.8VSUS (RT9043GB) PAGE 27
- CPU CORE (ISL6262ACRZ-T) PAGE 28
- DDR III SMD DR +1.5VSUS (RT8207AGQW) PAGE 29
- SYSTEM DISCHARGER PAGE 30

Keyboard PAGE 23  
Touch Pad PAGE 23

FAN PAGE 24  
SPI PAGE 24

 <b>NBS</b>	<b>PROJECT :AX3</b>		Rev 1A
	Quanta Computer Inc.		
Size Custom	Document Number	Block Diagram	
Date: Wednesday, November 25, 2009 Sheet 1 of 30			

3,4,5,6,8,9,14,17,27,28 +1.05V  
4,6,9,10,11,12,13,14,15,16,17,18,19,20,21,22,23,24,28,30 +3V

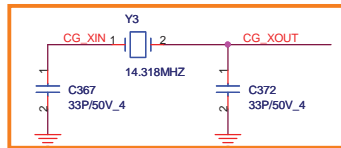
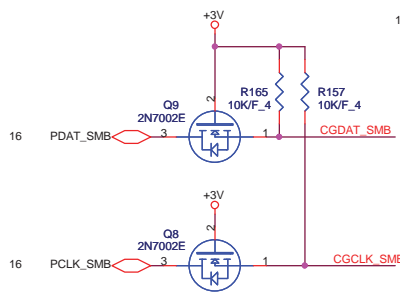
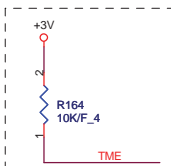
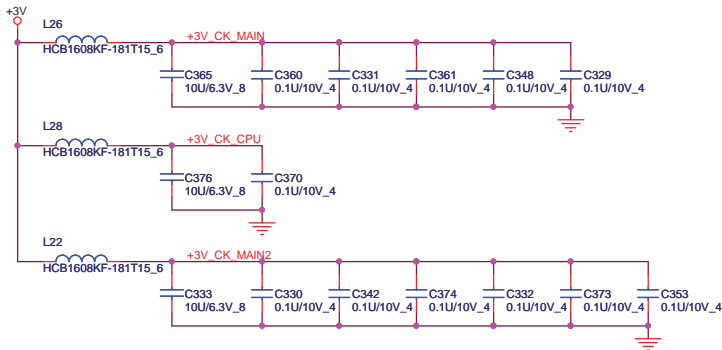

DB:Change from 27P to 33P(TXC suggestion)

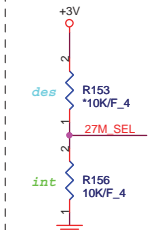

0=UMA  
1 = External VGA

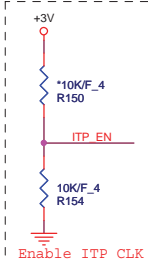

Enable ITP CLK

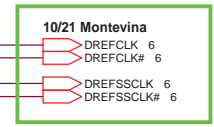
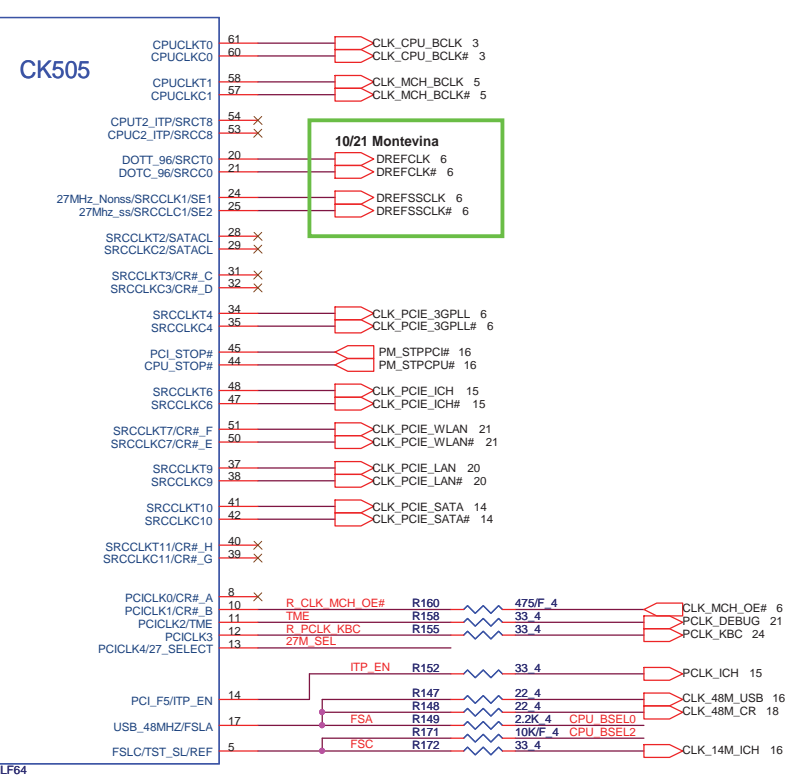
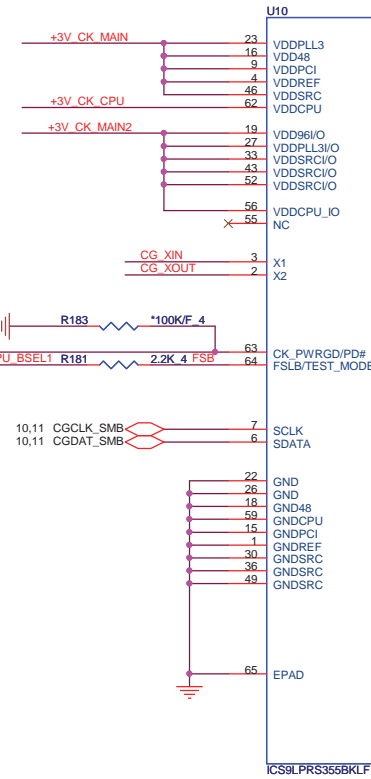

27M_SEL PIN13	PIN20	PIN21	PIN24	PIN25
0=UMA	DOT96T	DOT96C	SRCT1/LCDT_100	SRCT1/LCDT_100
1 = External VGA	SRCT0	SRCC0	27Mout-NSS	27Mout-SS

CK505 QFN64

Silego SLG8SP513VTR AL8SP513000  
Realtek RTM875N-606-VD-GR AL000875000  
ICS ICS9LPRS355BKLF ALPRS355000



CPU Clock select

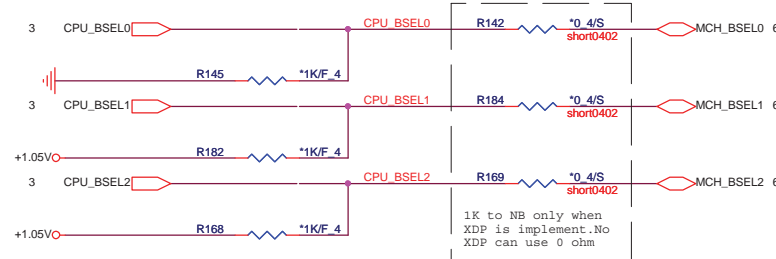

1k to NB only when XDP is implement.No XDP can use 0 ohm

FSC	FSB	FSA	CPU	SRC	PCI
1	0	1	100	100	33
0	0	1	133	100	33
0	1	1	166	100	33
0	1	0	200	100	33
1	0	0	333	100	33
1	1	0	400	100	33
1	1	1	RSVD	100	33

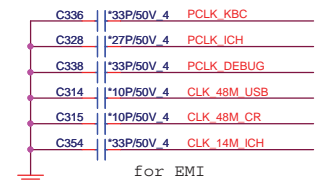

**PROJECT :AX3**  
Quanta Computer Inc.

Size Custom	Document Number	Rev 1A
<b>Clock Generator</b>		
Date: Friday, November 27, 2009		Sheet 2 of 30



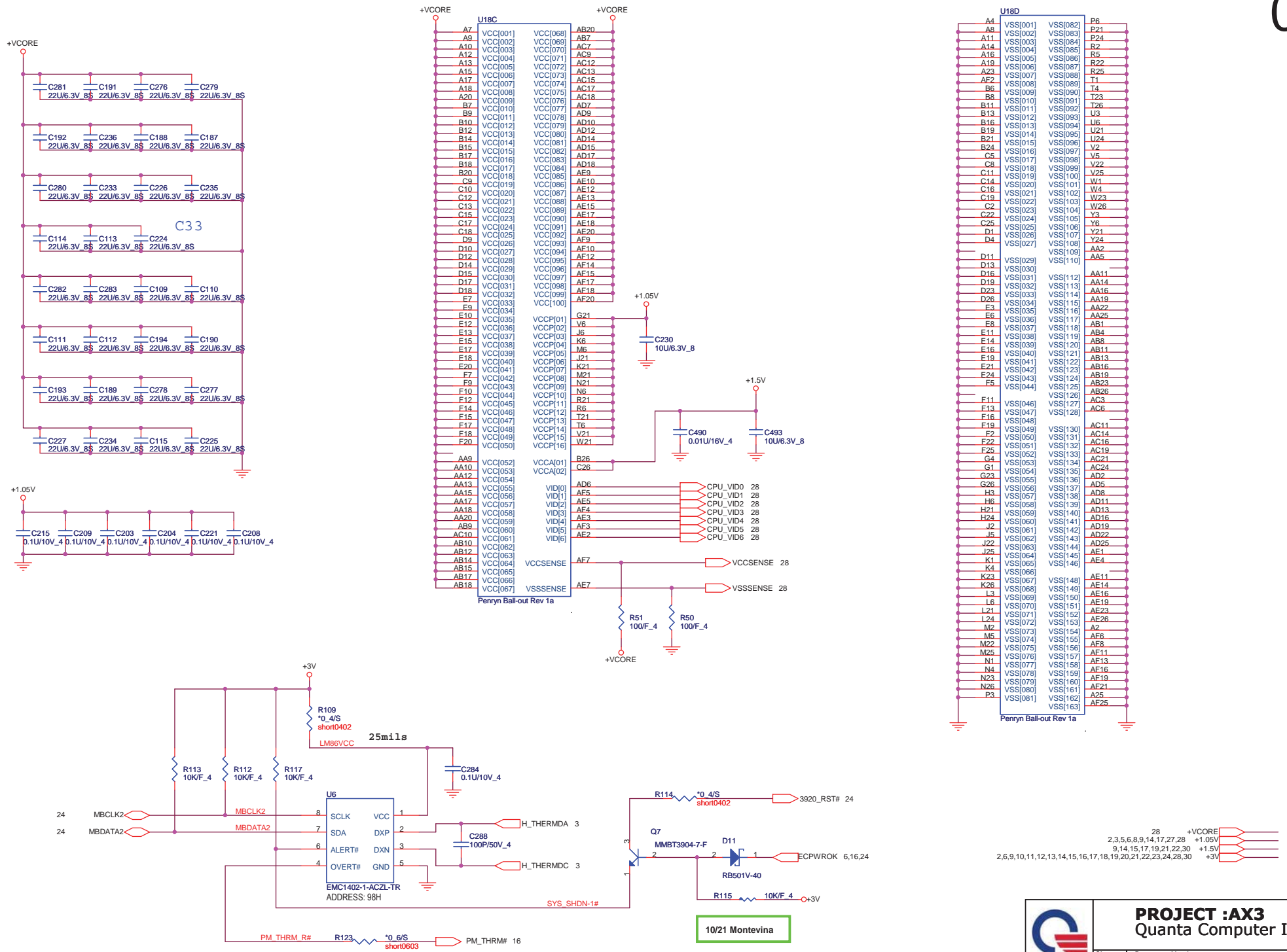

**PROJECT :AX3**  
 Quanta Computer Inc.

Size Custom Document Number Penryn & TH Monitor 2/2 Rev 1A  
 Date: Friday, November 27, 2009 Sheet 4 of 30

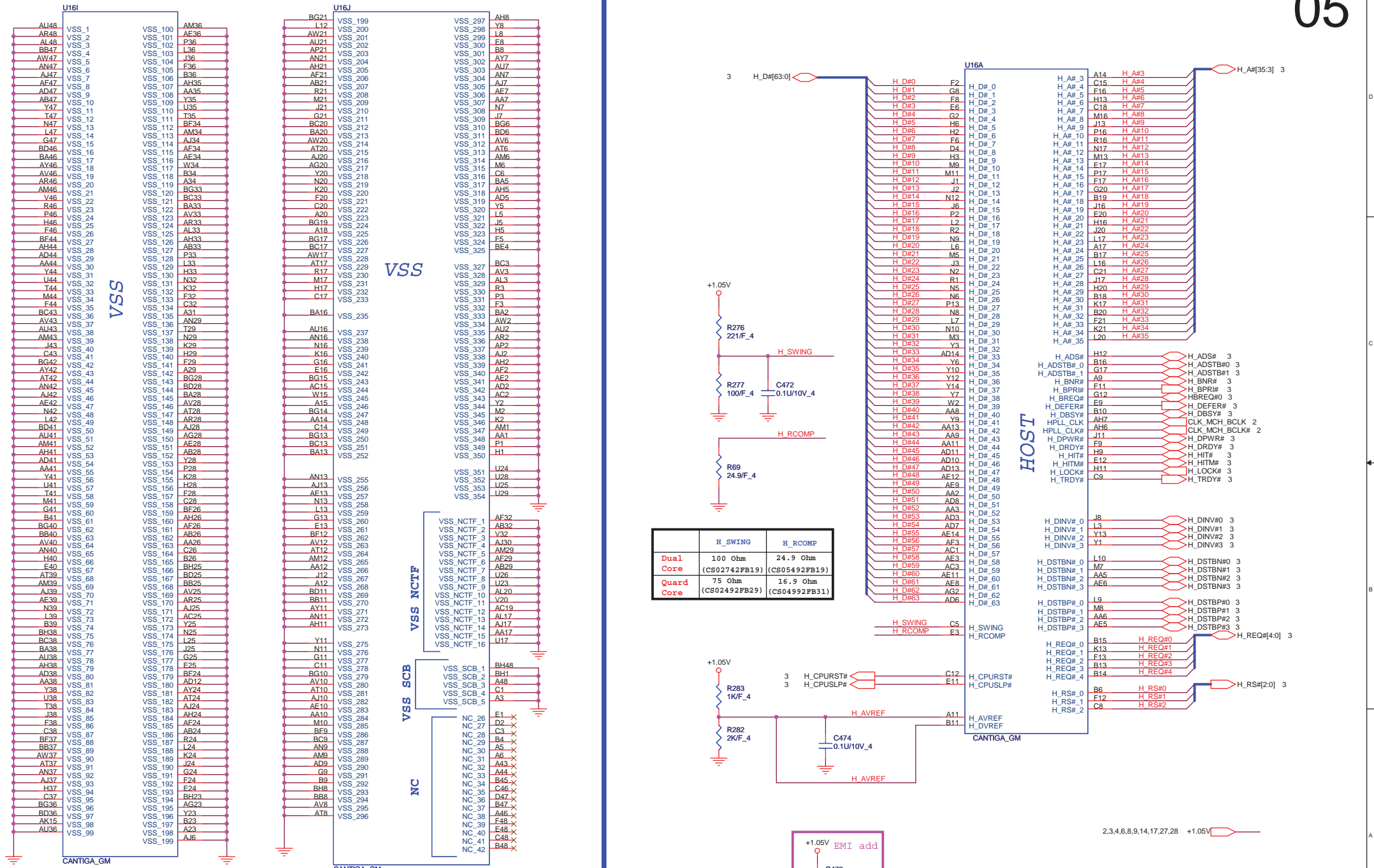

2,3,4,6,8,9,14,17,27,28 +1.05V

**PROJECT :AX3**  
Quanta Computer Inc.

Size Custom Document Number  
NB5 Cantiga Host & VSS 1/5 Rev 1A

Date: Friday, November 27, 2009 Sheet 5 of 30



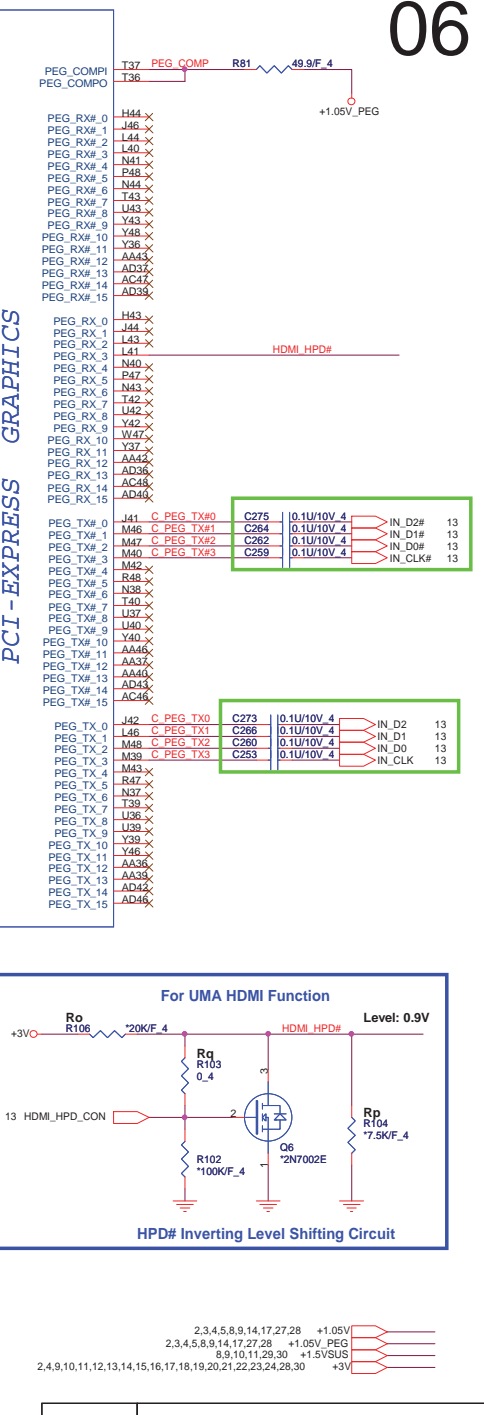
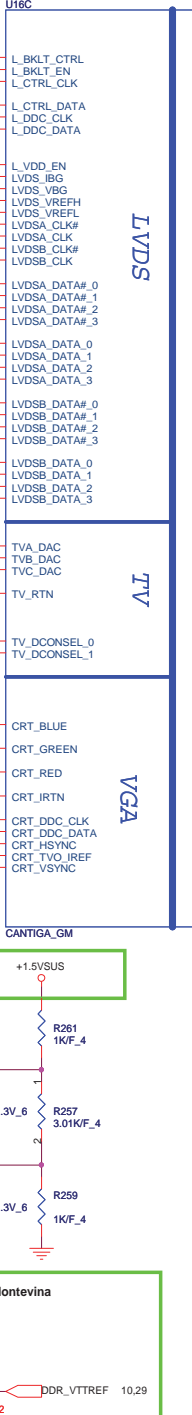
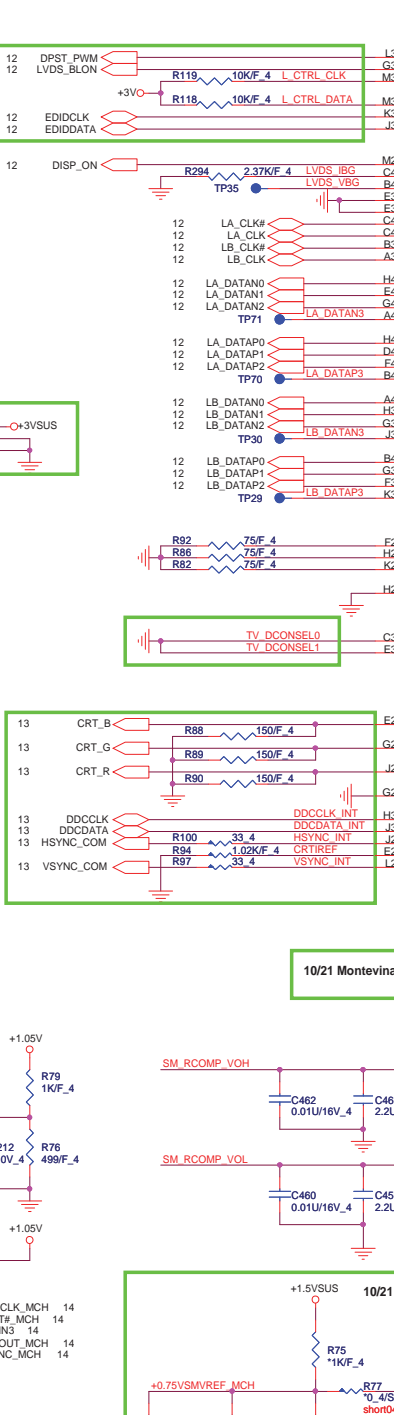
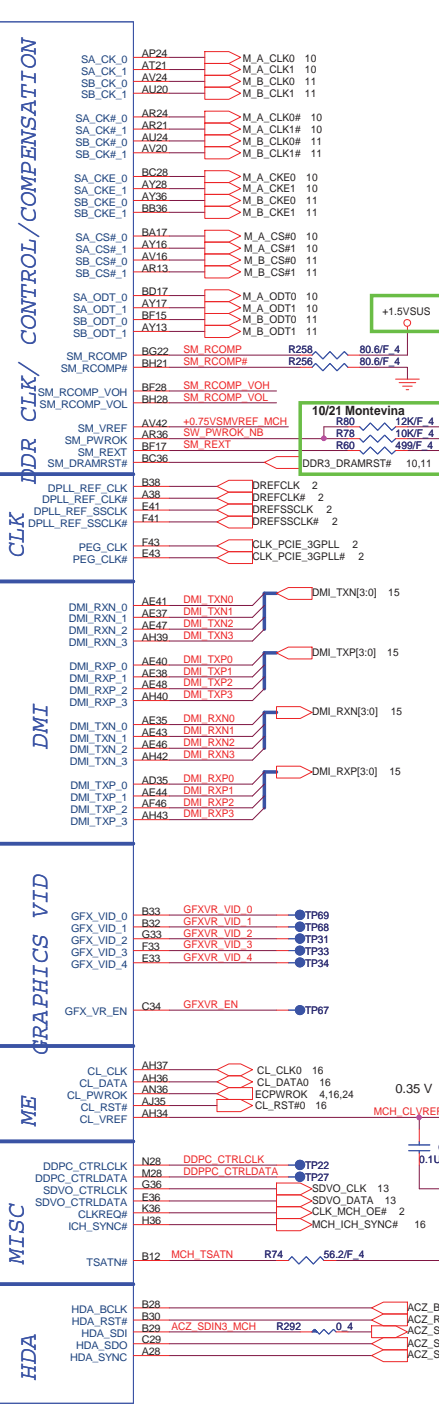
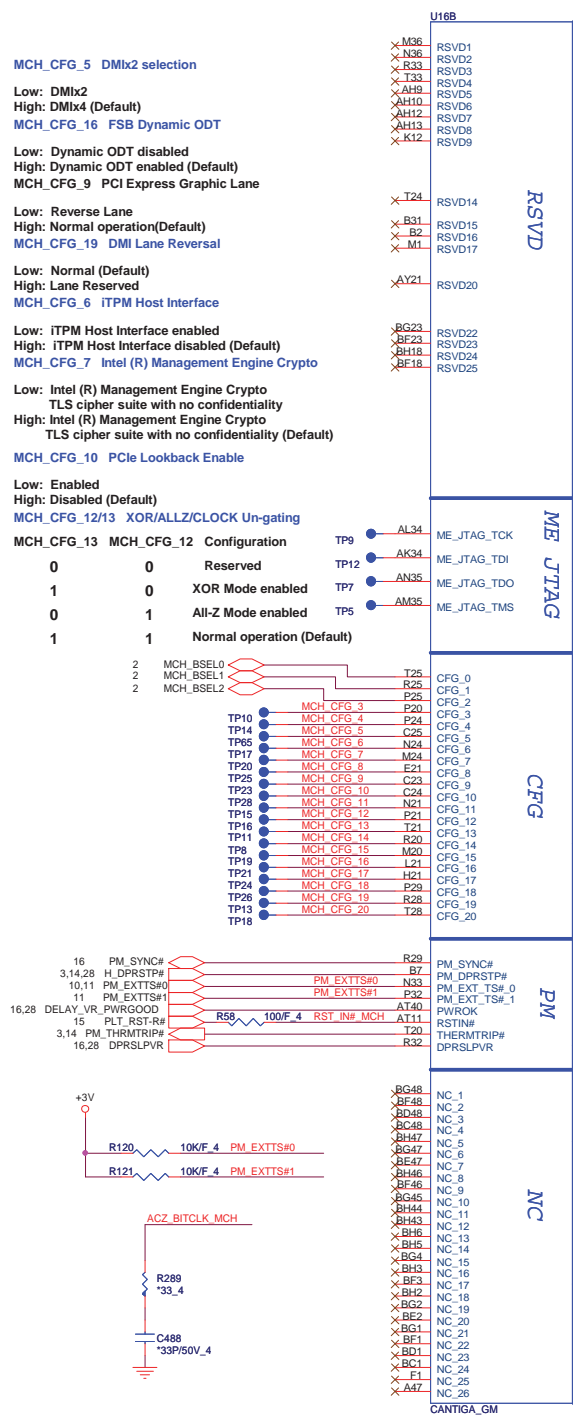

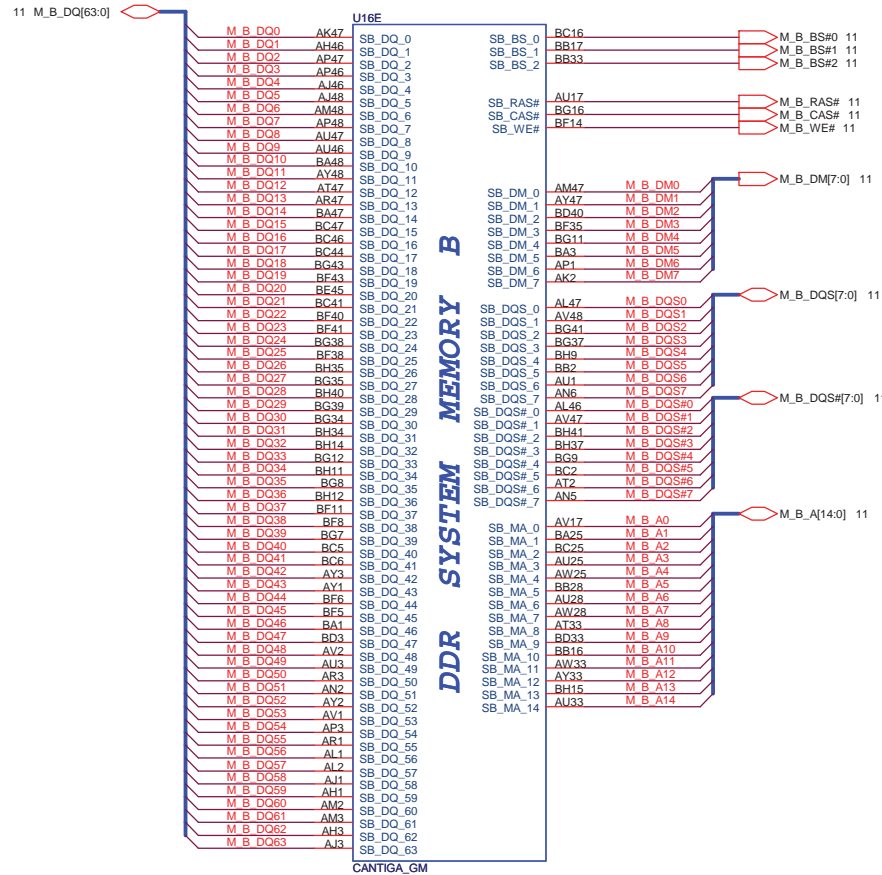
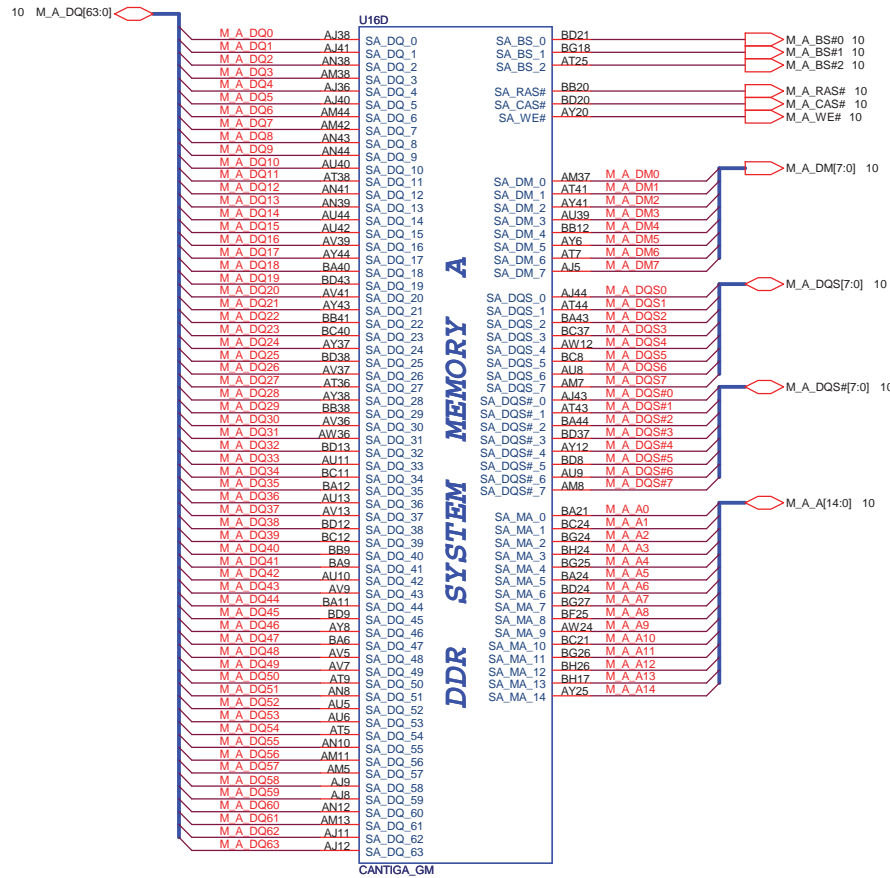

**PROJECT :AX3**  
 Quanta Computer Inc.

Size Custom Document Number Cantiga DDR3 3/5 Rev 1A  
 Date: Friday, November 27, 2009 Sheet 7 of 30

NBS5

10/21 Montevina +1.5VSUS

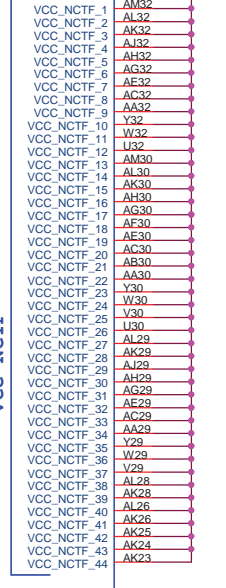
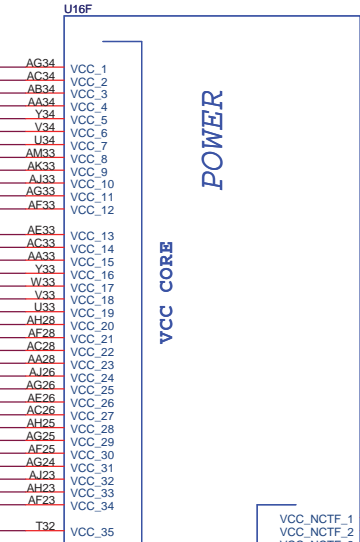
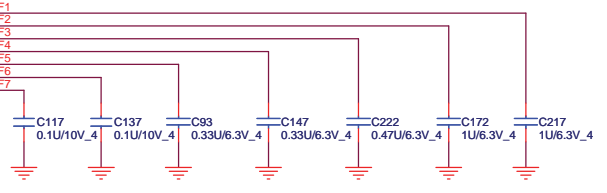
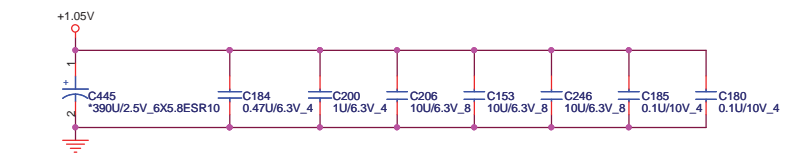
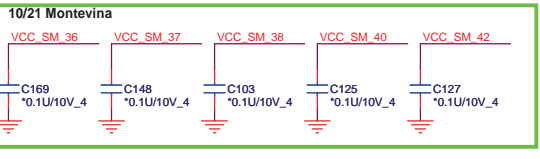
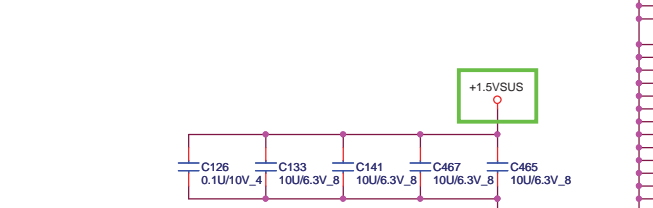
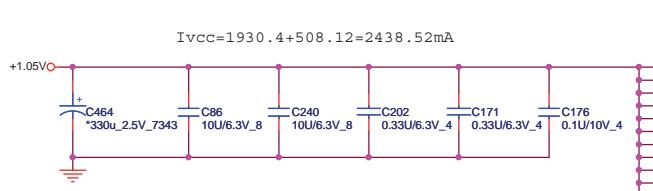
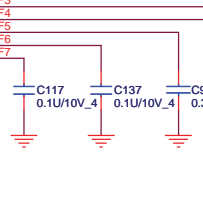
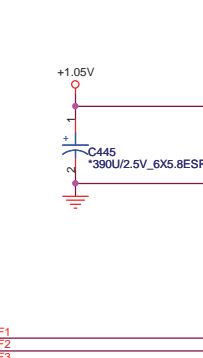
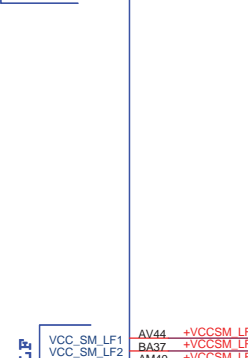
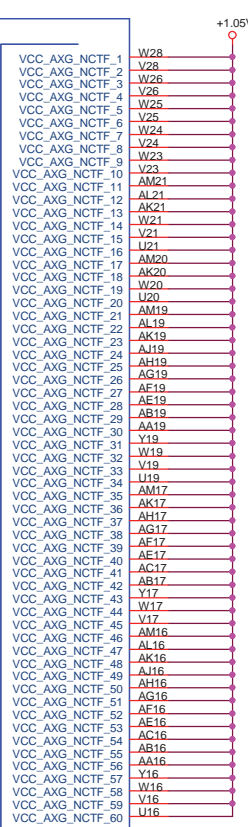
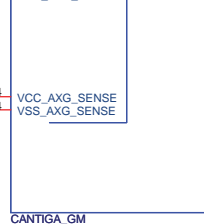
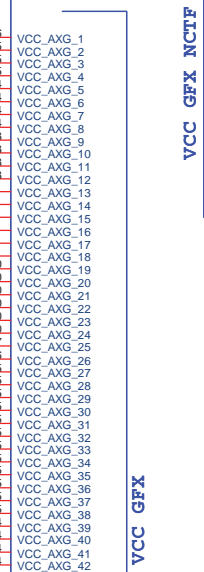
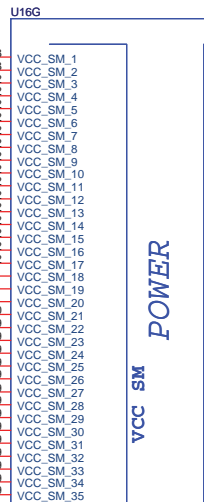
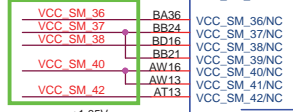
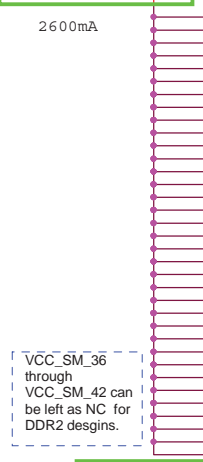

CANTIGA\_GM

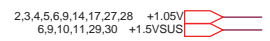
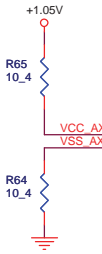

**PROJECT :AX3**  
Quanta Computer Inc.

Size Custom Document Number Cantiga VCC 4/5 Rev 1A

Date: Friday, November 27, 2009 Sheet 8 of 30

NBS





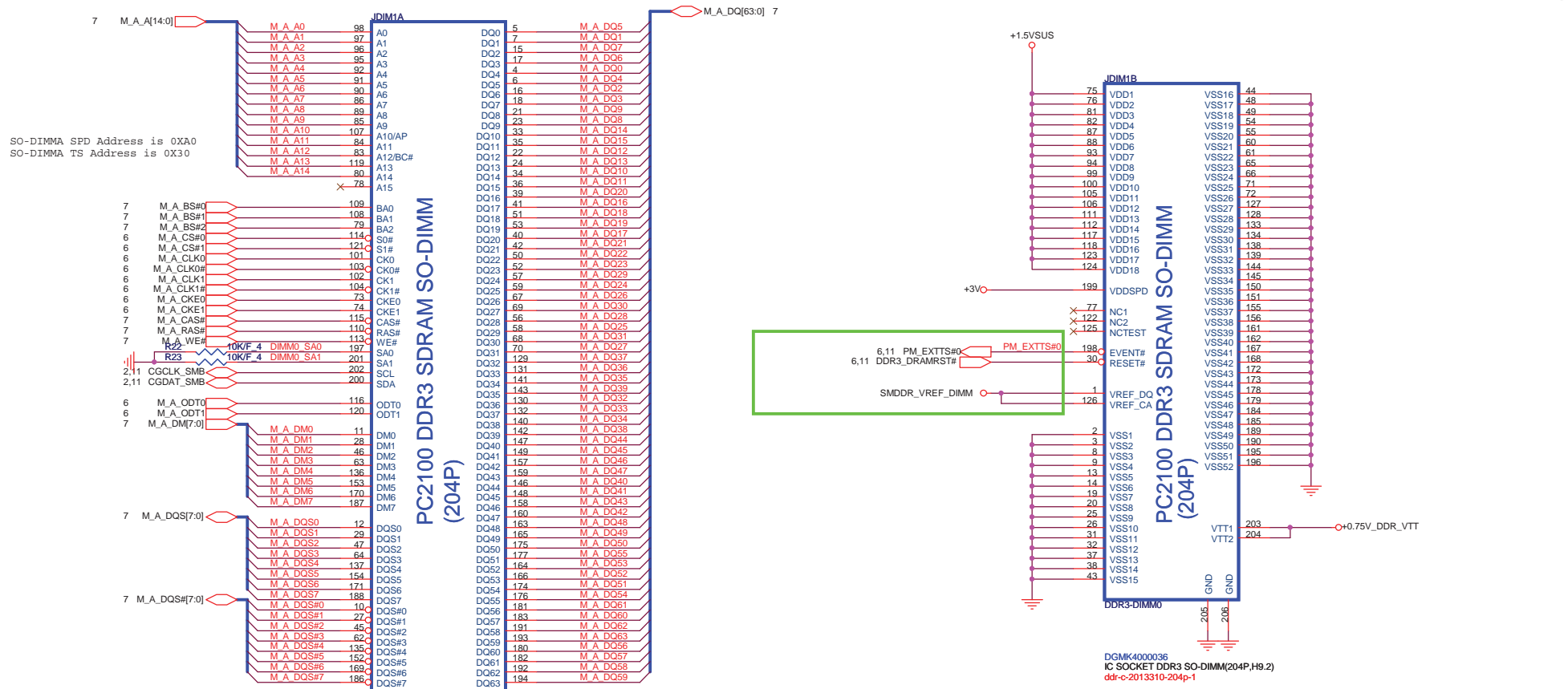

DDR3-DIMM0  
 DGMK4000036  
 IC SOCKET DDR3 SO-DIMM(204P,H9.2)  
 ddr-c-2013310-204p-1  
 Reverse type change to Standard type.

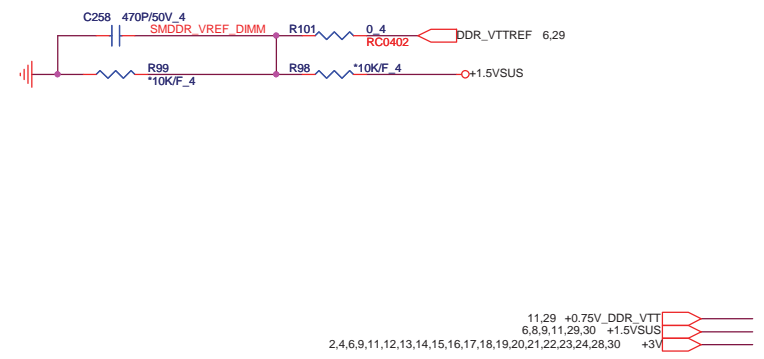
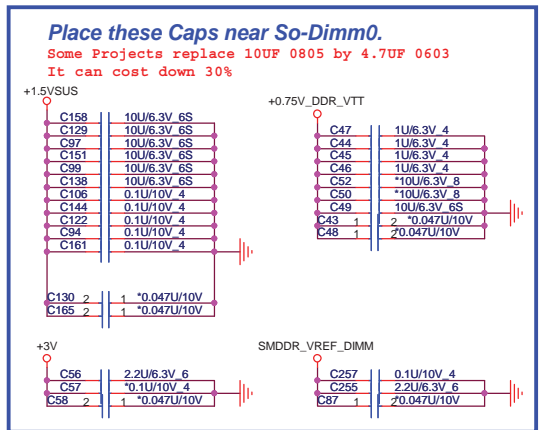

**PROJECT :AX3**  
 Quanta Computer Inc.

Size Custom	Document Number <b>DDR3 DIMM-0</b>	Rev 1A
Date: Friday, November 27, 2009		Sheet 10 of 30

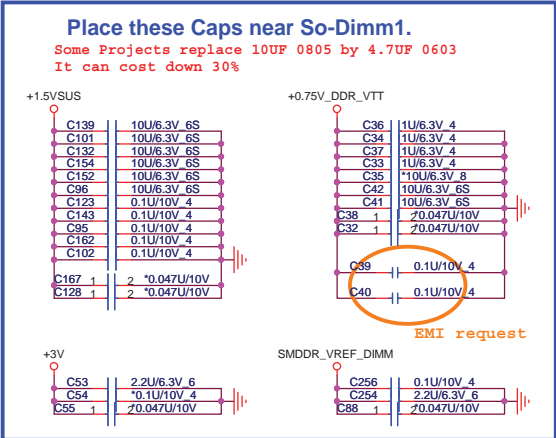
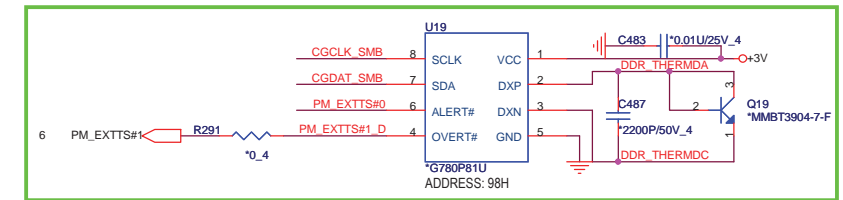
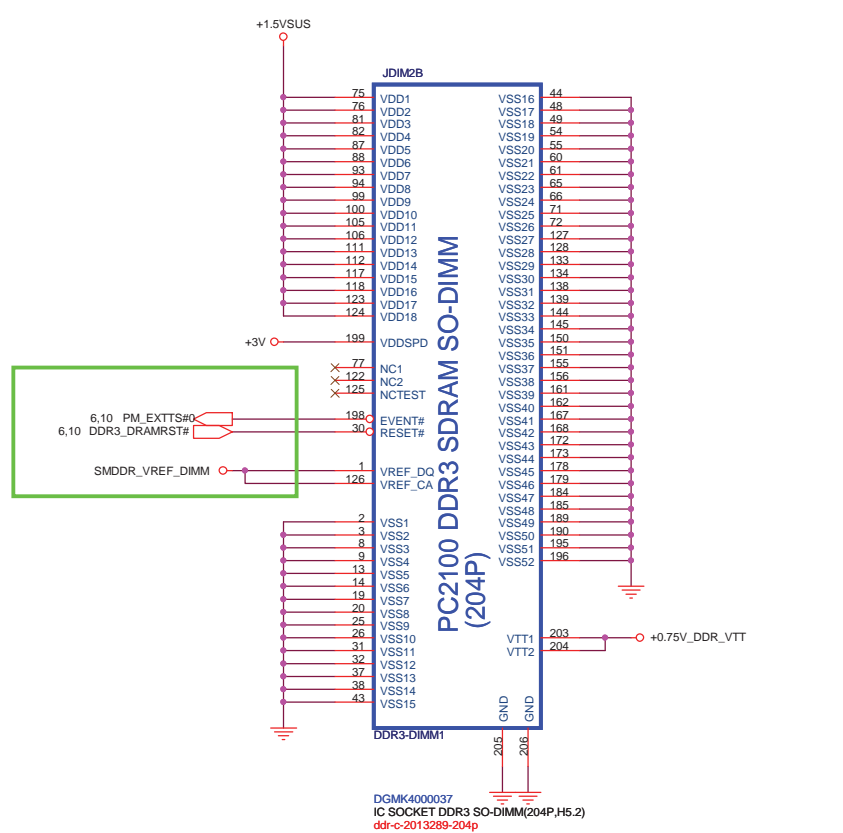
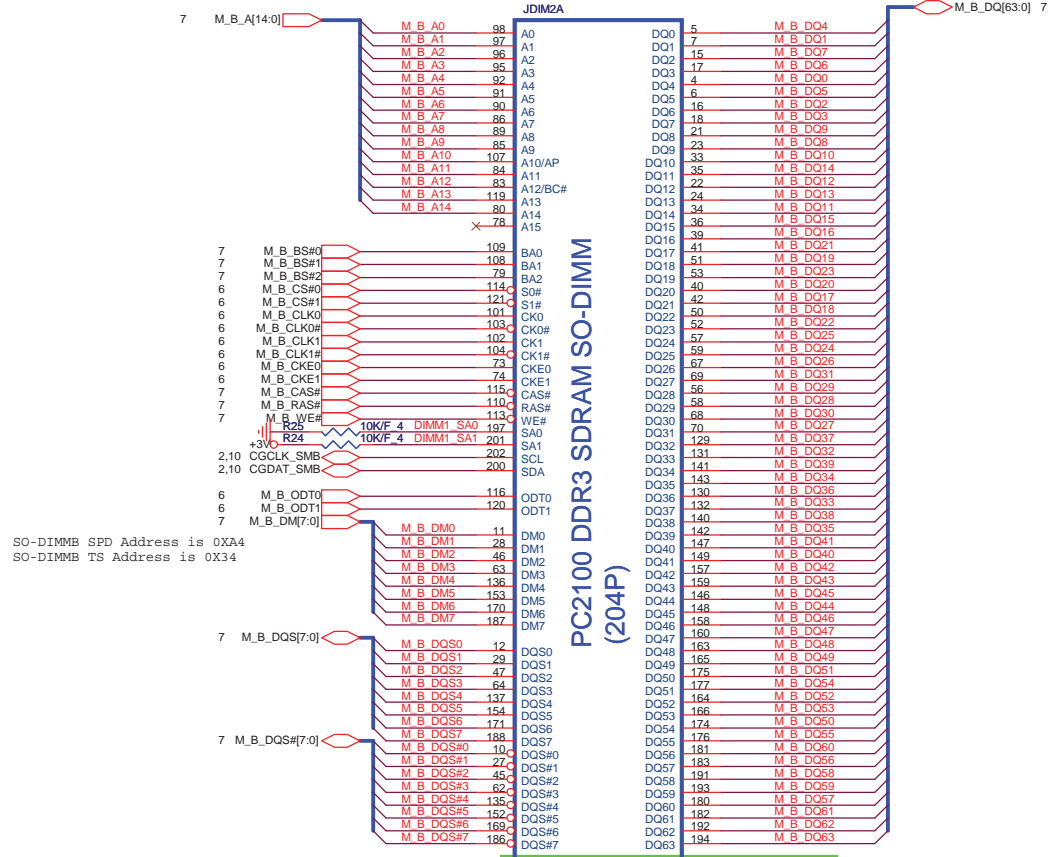

**PROJECT :AX3**  
Quanta Computer Inc.

Size Custom Document Number **DDR3 DIMM-1** Rev 1A

Date: Friday, November 27, 2009 Sheet 11 of 30

NBS5

# LID Switch

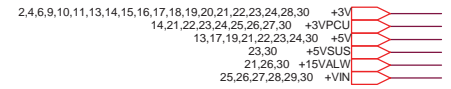
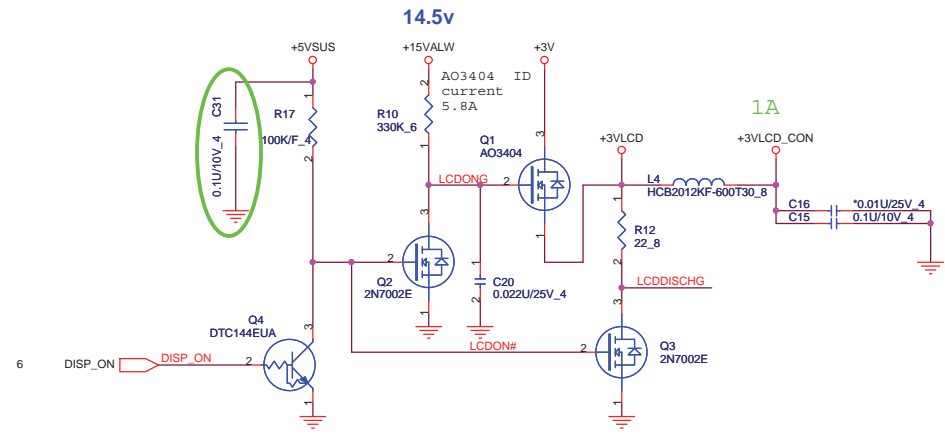
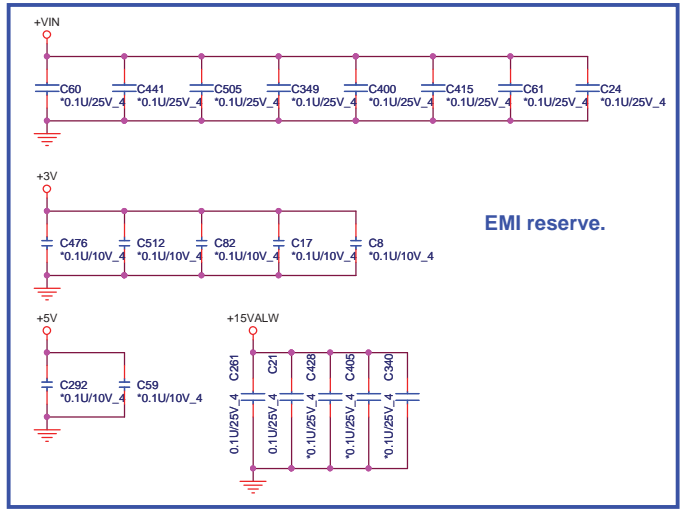
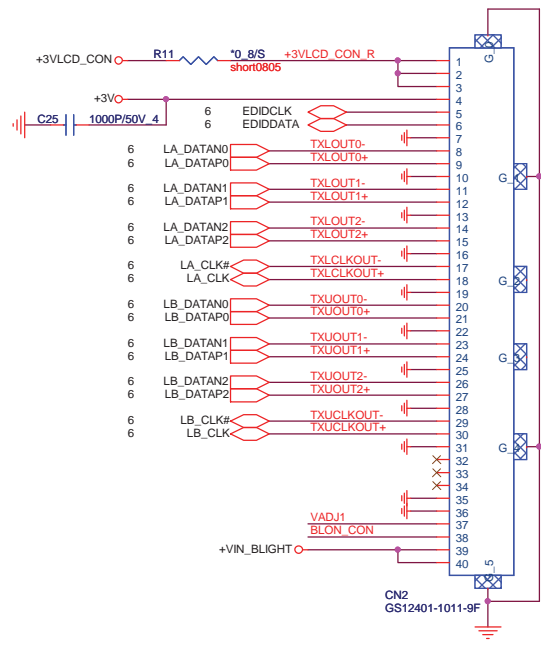
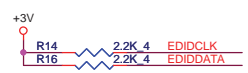
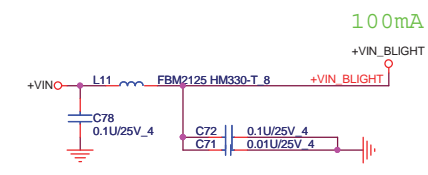
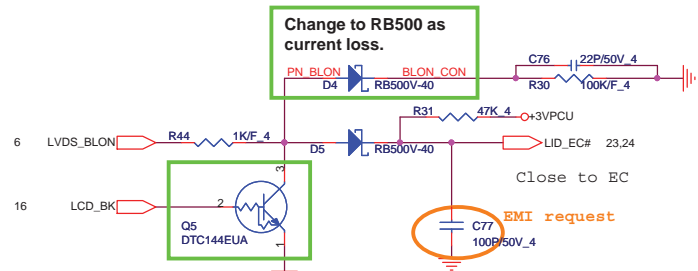

**PROJECT :AX3**  
Quanta Computer Inc.

Size Custom Document Number **LCD CONN/LID** Rev 1A

Date: Friday, November 27, 2009 Sheet 12 of 30

CRT PORT

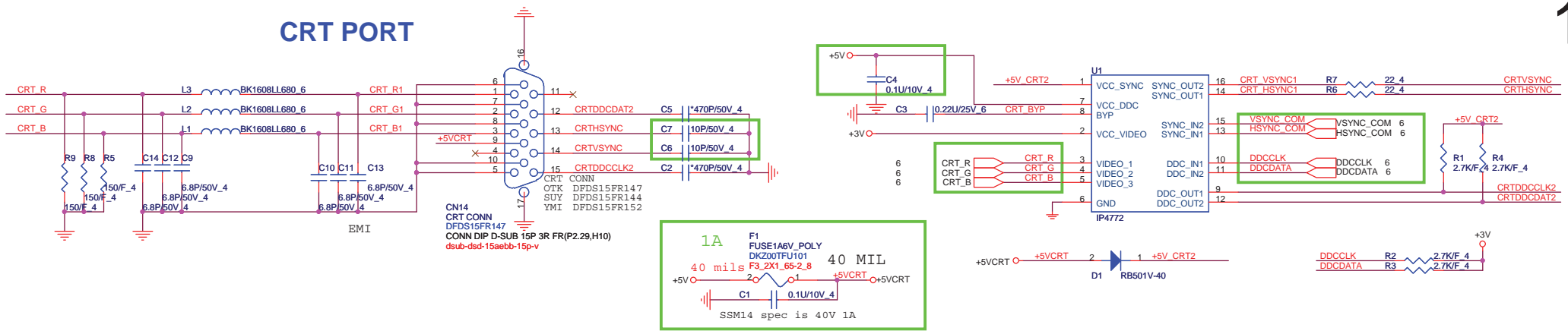

For UMA HDMI function

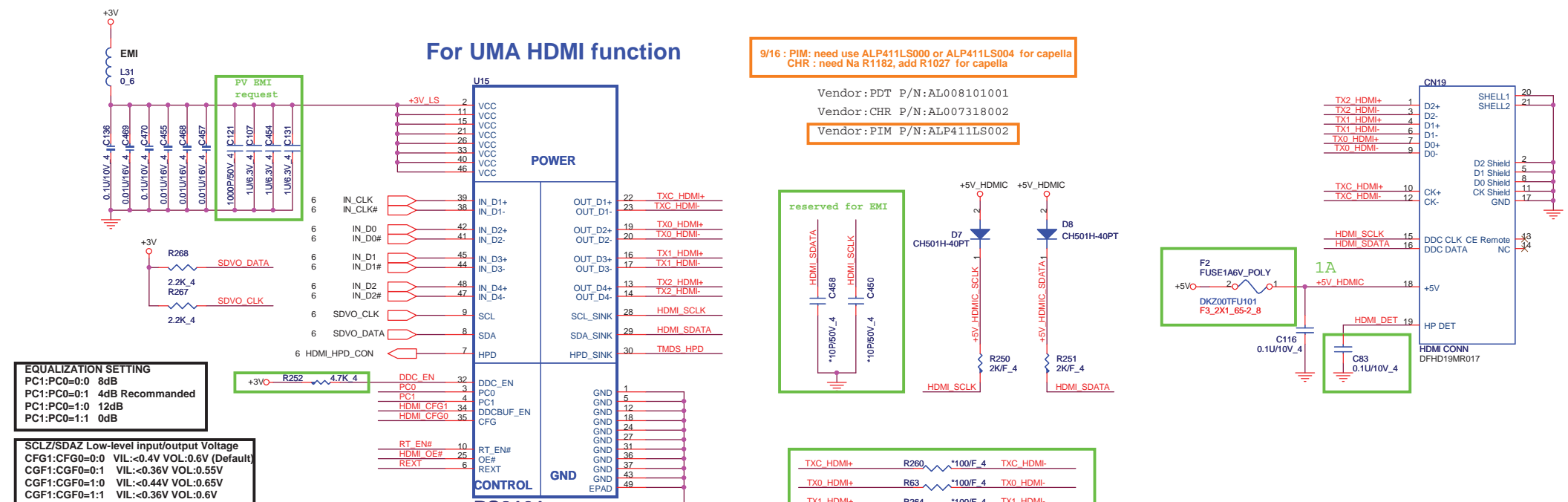

**EQUALIZATION SETTING**  
 PC1:PC0=0:0 8dB  
 PC1:PC0=0:1 4dB Recommended  
 PC1:PC0=1:0 12dB  
 PC1:PC0=1:1 0dB

**SCLZ/SDAZ Low-level input/output Voltage**  
 CFG1:CFG0=0:0 VIL:<0.4V VOL:0.6V (Default)  
 CGF1:CGF0=0:1 VIL:<0.36V VOL:0.55V  
 CGF1:CGF0=1:0 VIL:<0.44V VOL:0.65V  
 CGF1:CGF0=1:1 VIL:<0.36V VOL:0.6V

Signals	R	PDT	CHR	PIM
PC0	Ra	4.7K	NC	NC
	Rb	NC	NC	0
PC1	Rc	NC	10K	NC
	Rd	NC	NC	0
HDMI_CFG0	Re	NC	10K	NC
	Rf	NC	NC	0
HDMI_CFG1	Rg	NC	10K	NC
	Rh	NC	NC	0
REXT	Ri	499	1.2K	0
RT_EN#	Rj	NC	NC	0
HDMI_OE#	Rk	NC	0	0

Detect	R	PDT	CHR	PIM
IC	Rm	0	20K	0
	Rn	NC	47K	NC
NB (Page6)	Ro	NC	20K	20K
	Rp	NC	7.5K	7.5K
	Rq	0	0	0

**PROJECT :AX3**  
 Quanta Computer Inc.

**NBS5**

Size Custom Document Number **CRT/HDMI Conn** Rev 1A  
 Date: Friday, November 27, 2009 Sheet 13 of 30



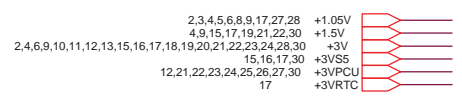
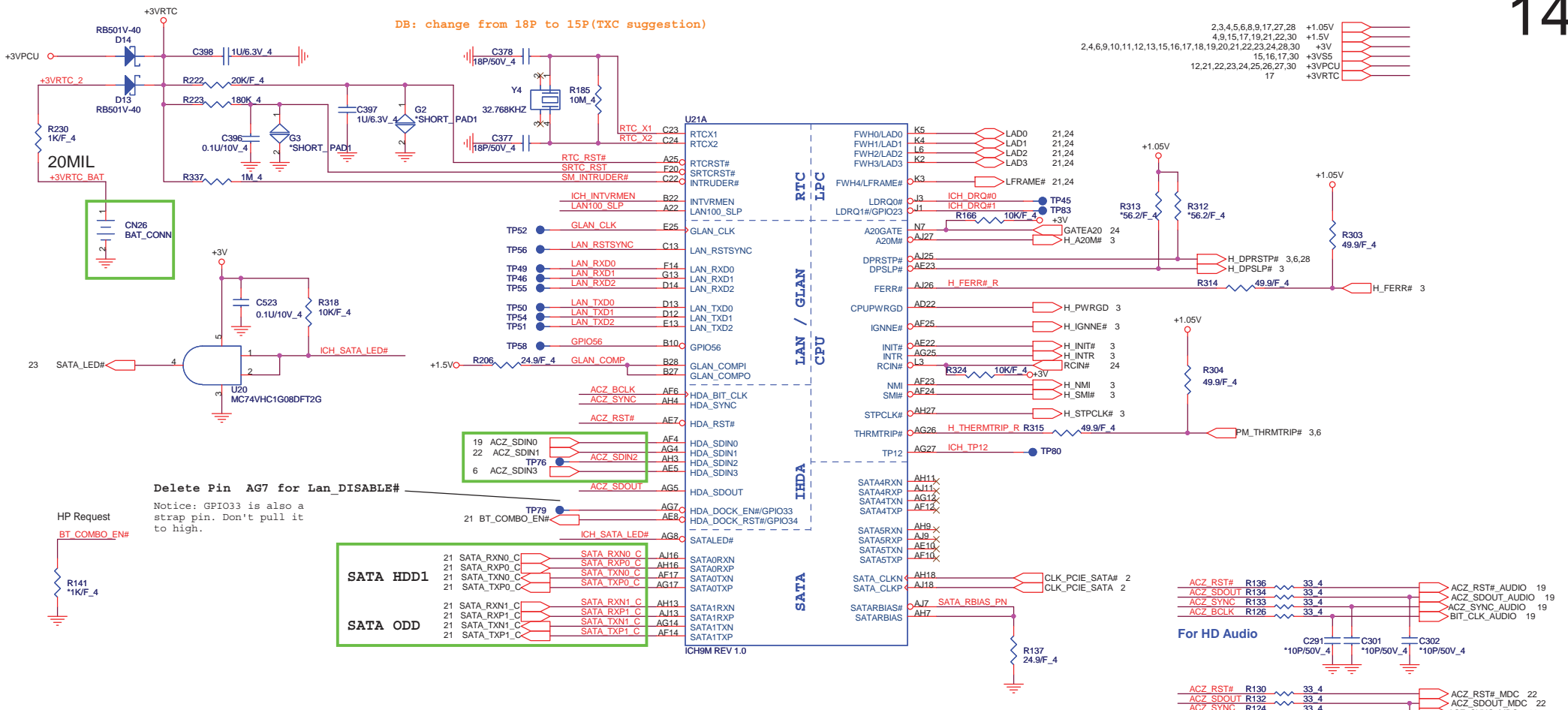

Delete Pin AG7 for Lan\_DISABLE#  
 Notice: GPIO33 is also a strap pin. Don't pull it to high.

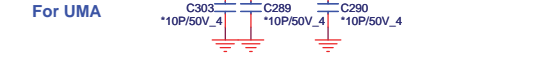
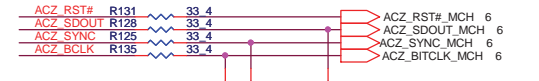
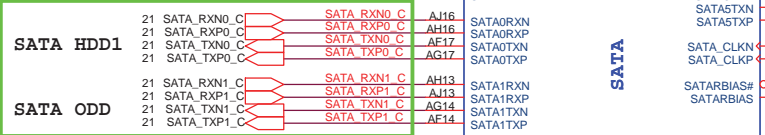

**SB Strap**

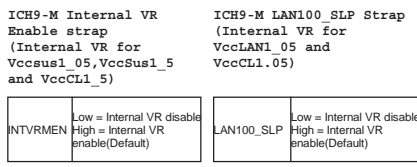

**XOR Chain Entrance Strap**

ICH_TP3	HDA_SDOUT	Description
0	0	RSVD
0	1	Enter XOR Chain
1	0	Normal opration(Default)
1	1	Set PCIe port config bit 1

**ICH9 Boot BIOS select**

STRAP	PCI_GNT0#	SPI_CS#1
SPI	0	1
PCI	1	0
LPC	1	1

(default)

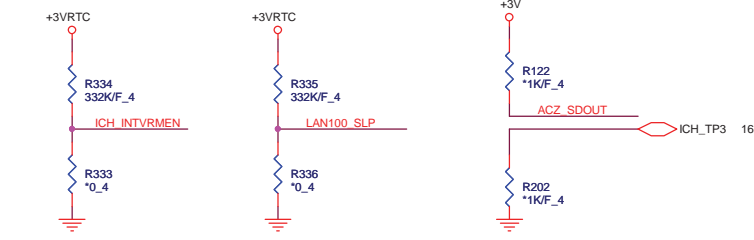
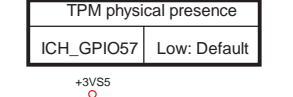
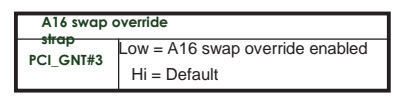
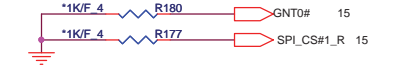
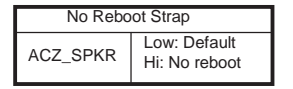

**PROJECT :AX3**  
 Quanta Computer Inc.

Size Custom Document Number ICH9-M SATA/HDA/RTC 1/4 Rev 1A  
 Date: Friday, November 27, 2009 Sheet 14 of 30

MINI CARD PCI-E (WLAN)

PCI-E-LAN

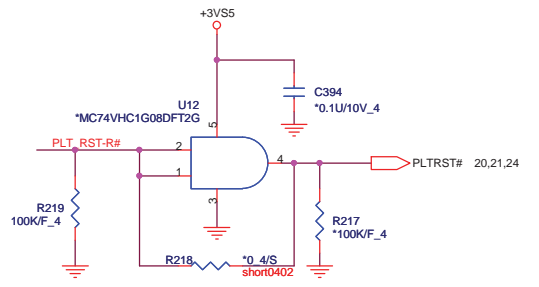
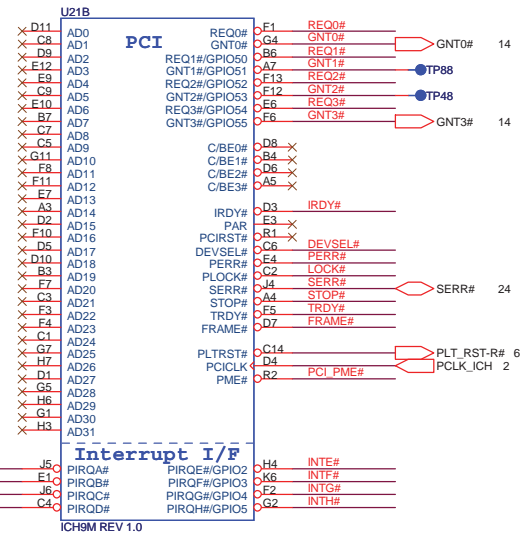
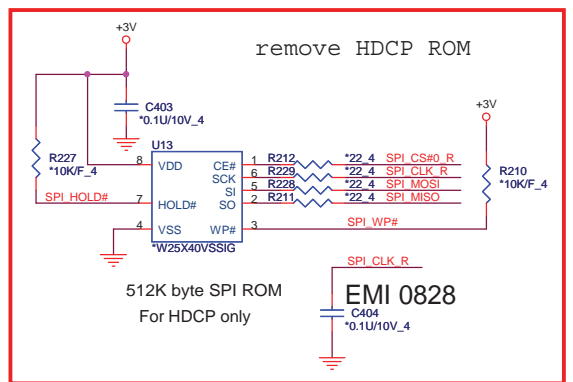
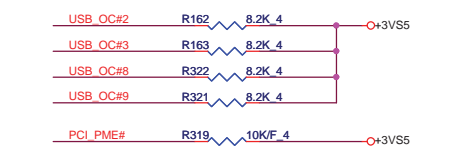
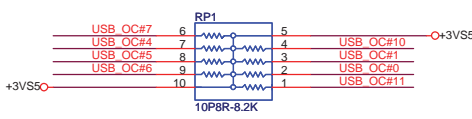
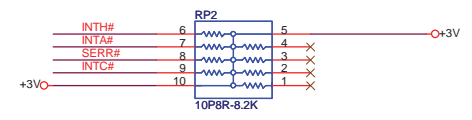
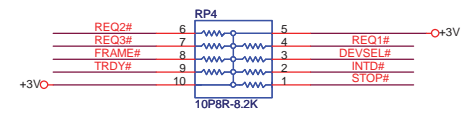
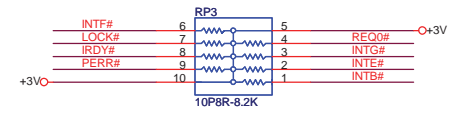
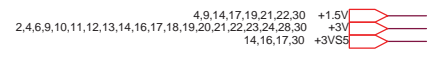
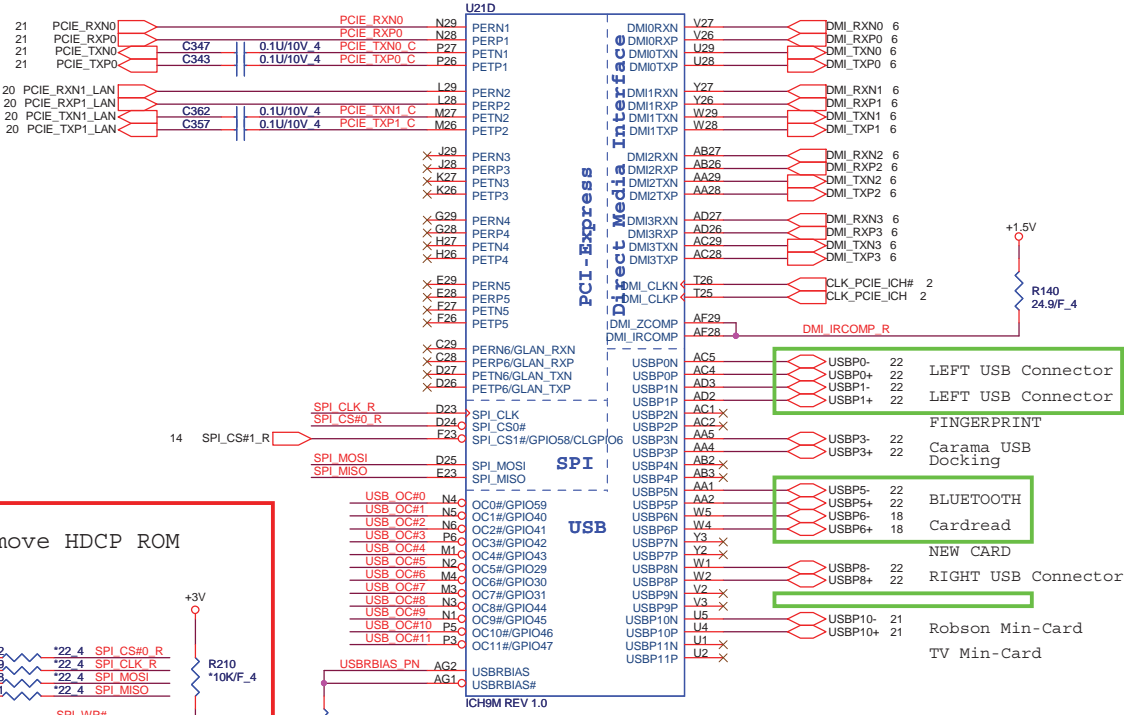

**PROJECT :AX3**  
Quanta Computer Inc.

Size Custom Document Number ICH9-M DMI/PCIe/USB 2/4 Rev 1A

Date: Friday, November 27, 2009 Sheet 15 of 30

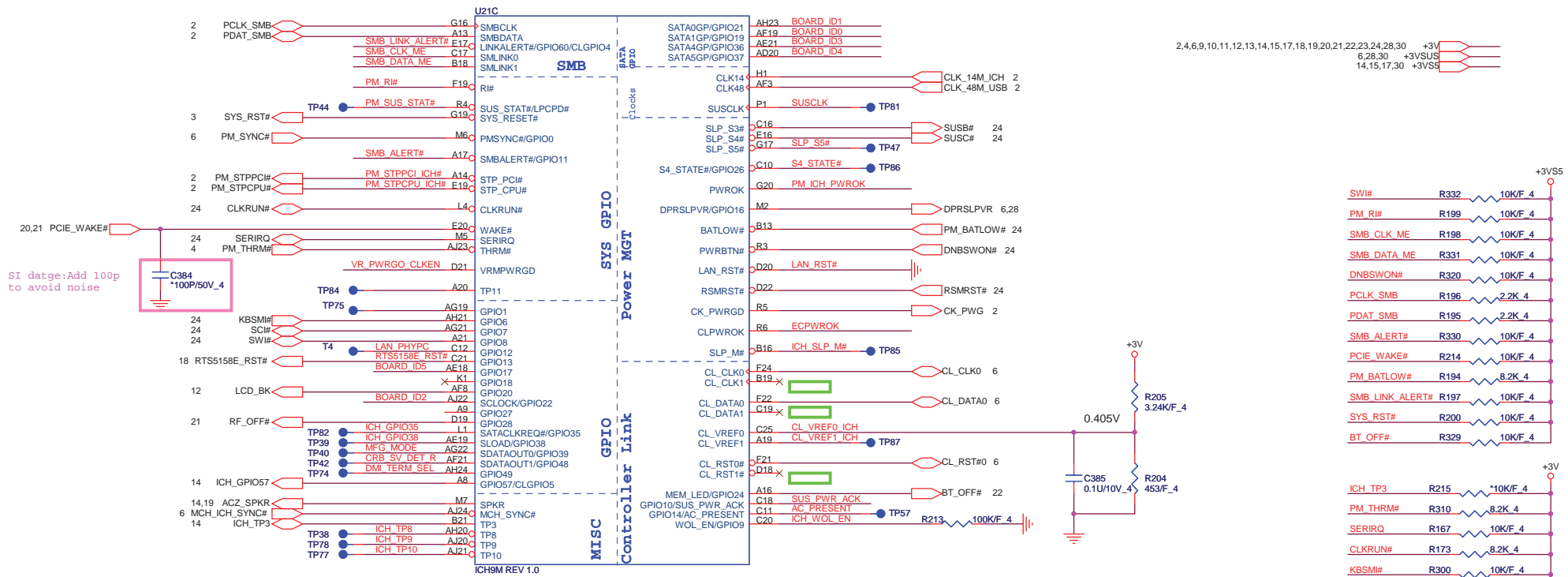

SI datge:Add 100p to avoid noise

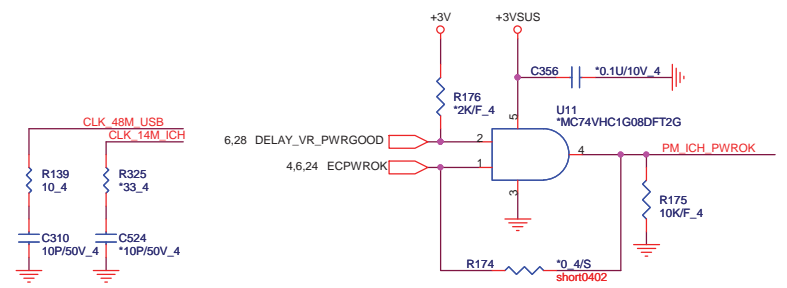
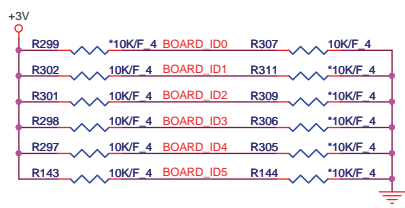
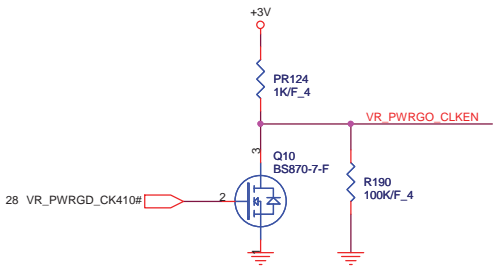
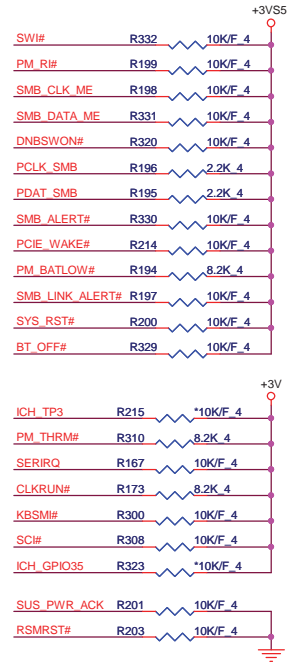
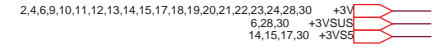
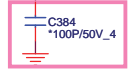

Board ID	ID0	ID1	ID2	ID3	ID4	ID5
	GPIO19	GPIO21	GPIO22	GPIO36	GPIO37	GPIO17
UMA/DIS	0=UMA 1=Dis.					
CardReader		0=No 1=Yes				
HDMI			0=No 1=Yes			
Bluetooth				0=No 1=Yes		
Camera					0=No 1=Yes	
Modem						0=No 1=Yes

AX3 MB P/N	ID0	ID1	ID2	ID3	ID4	ID5
31AX6MB0000	0	1	1	1	1	1
31AX6MB0010	0	1	1	1	1	1
31AX6MB0020	0	1	1	1	1	1

**PROJECT :AX3**  
Quanta Computer Inc.

Size Custom Document Number ICH9-M GPIO/Board ID 3/4 Rev 1A

Date: Friday, November 27, 2009 Sheet 16 of 30

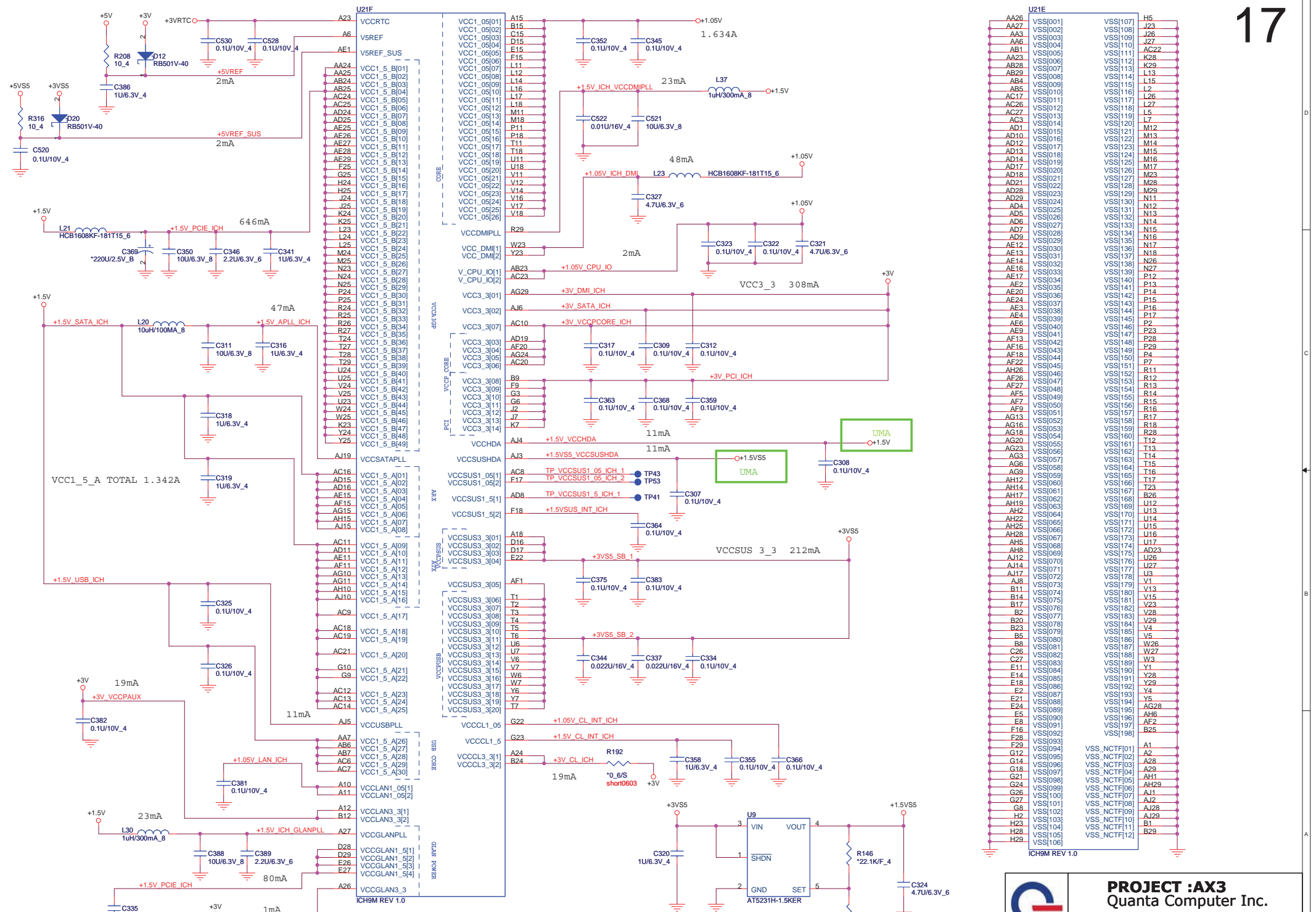

**PROJECT :AX3**  
**Quanta Computer Inc.**

Size Custom Document Number ICH9-M Power 4/4 Rev 1A  
 Date: Thursday, November 26, 2009 Sheet 17 of 30

PU for internal CLK input  
Unstuff for external XTAL(12MHZ)

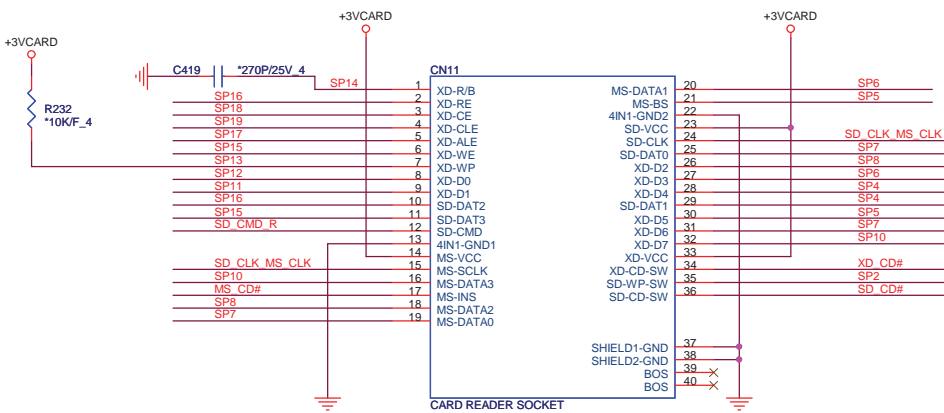
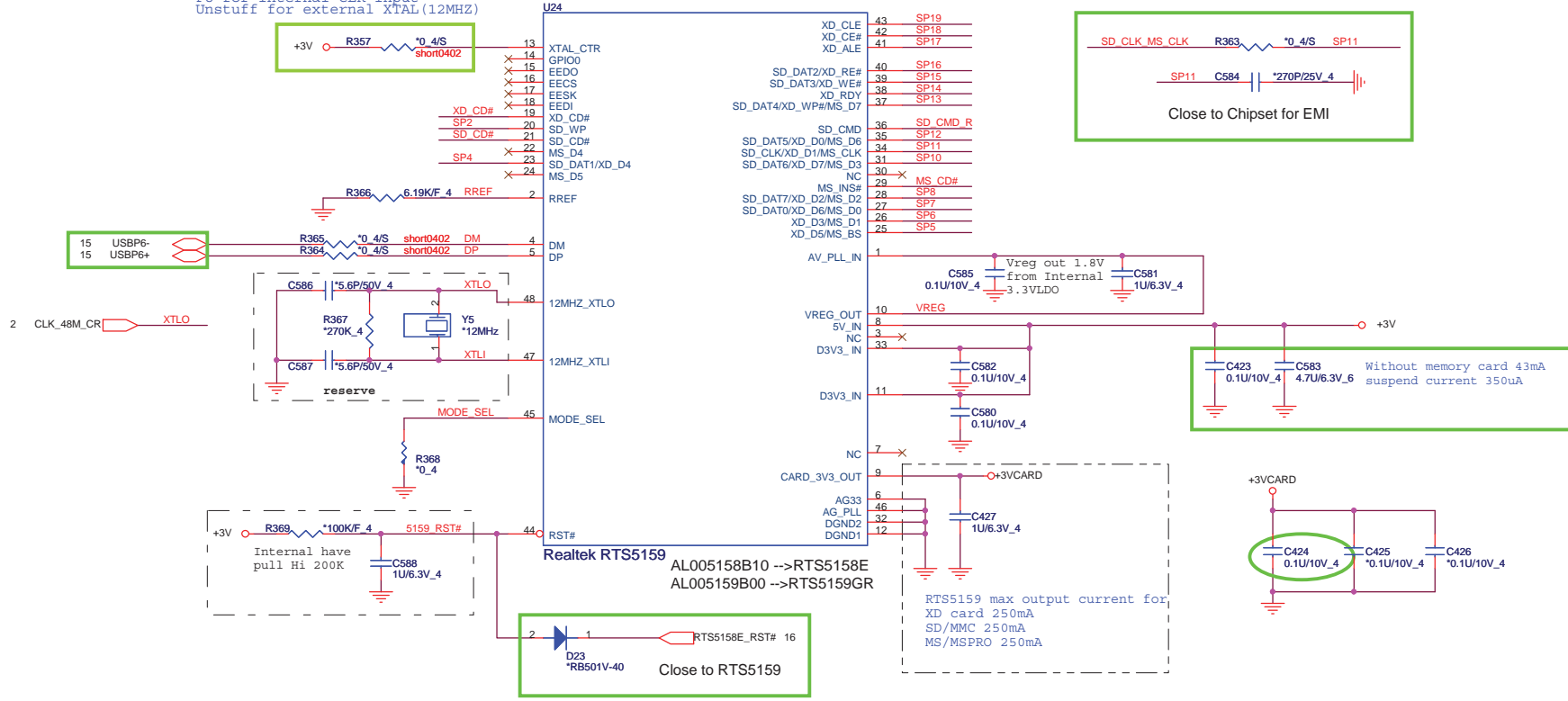

**5 IN1 CARD-READER (PUSH-PUSH)**

Support SD/SD PRO/MMC/MS/MS PRO/xD Cards

2,4,6,9,10,11,12,13,14,15,16,17,19,20,21,22,23,24,28,30 +3V

**Note:**

SP0	SD/MMC	MS	XD
SP1	SD WP		XD CD#
SP2	SD WP		
SP3	SD CD#		
SP4	SD DAT1		XD D4
SP5		MS BS	XD D5
SP6		MS D1	XD D3
SP7	SD DAT0	MS D0	XD D6
SP8	SD DAT7	MS D2	XD D2
SP9		MS INS#	
SP10	SD DAT6	MS D3	XD D7
SP11	SD CLK	MS SCLK	XD D1
SP12	SD DAT5		XD D0
SP13	SD DAT4		XD D4
SP14			XD R/B#
SP15	SD DAT3		XD WE#
SP16	SD DAT2		XD RE#
SP17			XD ALE
SP18			XD CE#
SP19			XD CLE

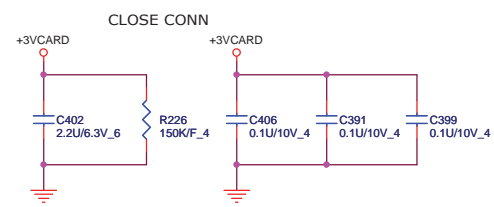

**PROJECT :AX3**  
Quanta Computer Inc.

Size Custom Document Number  
**RTS5159/CR Socket**

Date: Friday, November 27, 2009 Sheet 18 of 30

Rev 1A





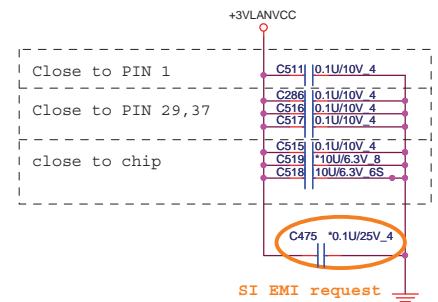
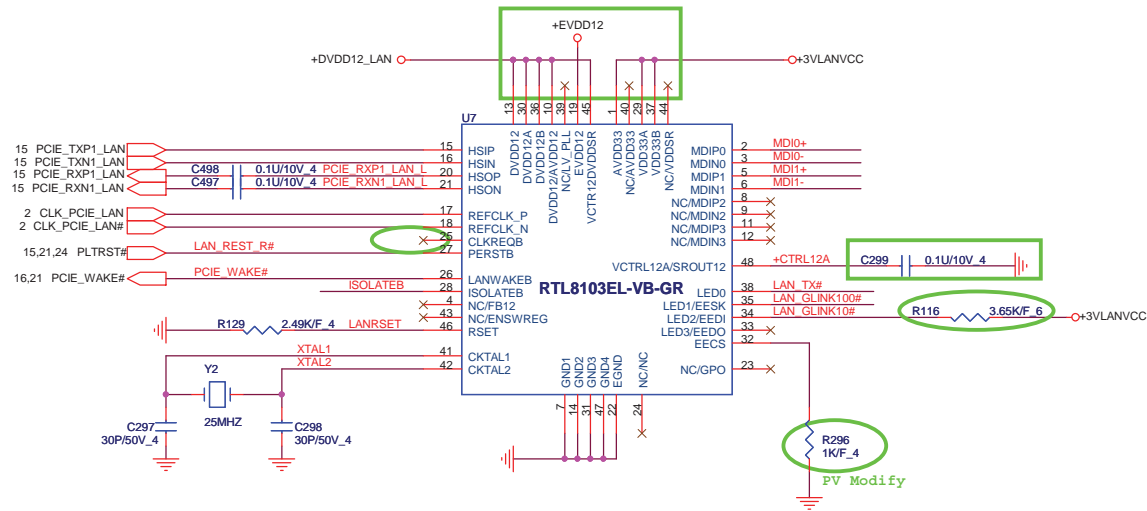

### Transformer for 10/100

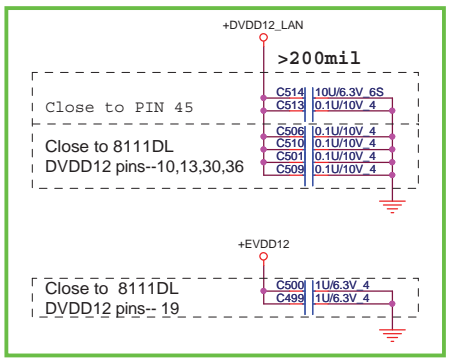
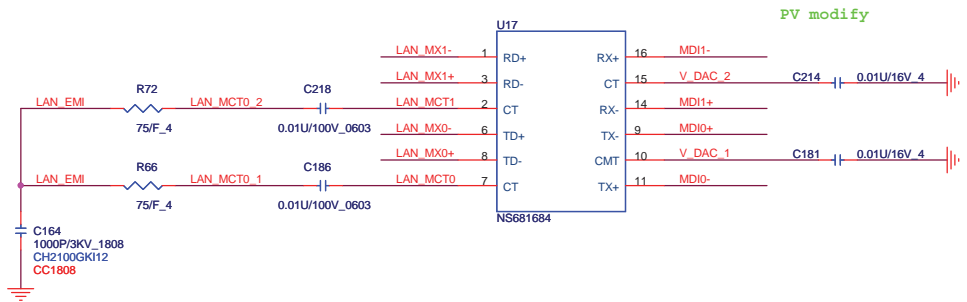

### Lan Con.

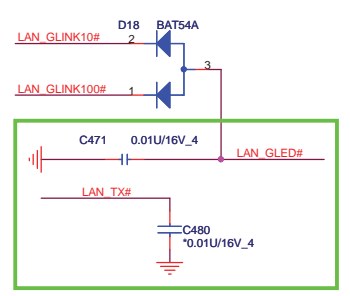

### RJ45

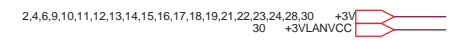
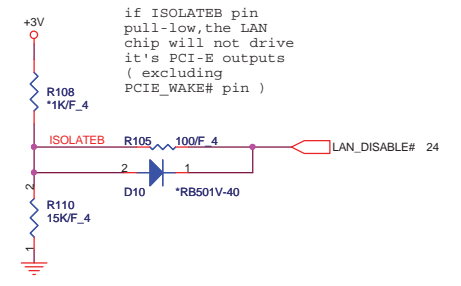
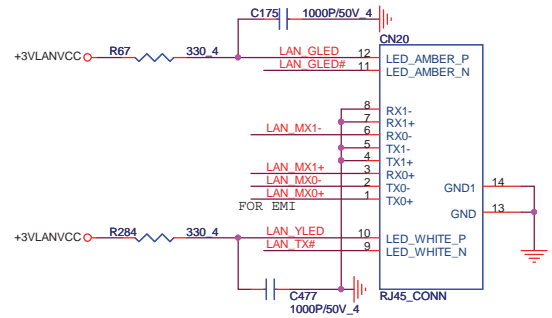

	<b>PROJECT :AX3</b>		Rev 1A
	Quanta Computer Inc.		
Size Custom	Document Number	RTL8103EL/RJ45	
Date: Friday, November 27, 2009	Sheet	20	of 30

### Mini PCI-E Card WLAN

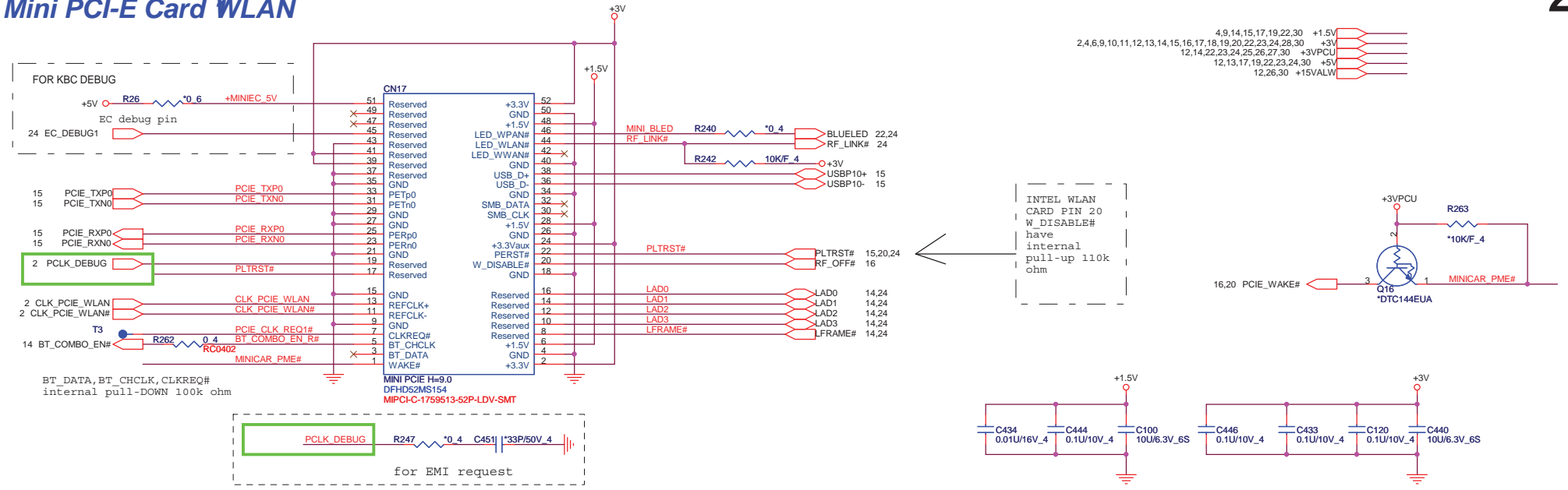

### SATA HDD CONNECTOR

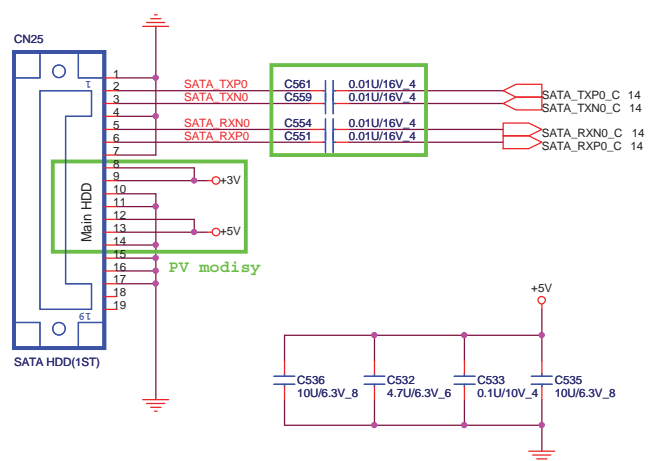

### SATA ODD CONNECTOR

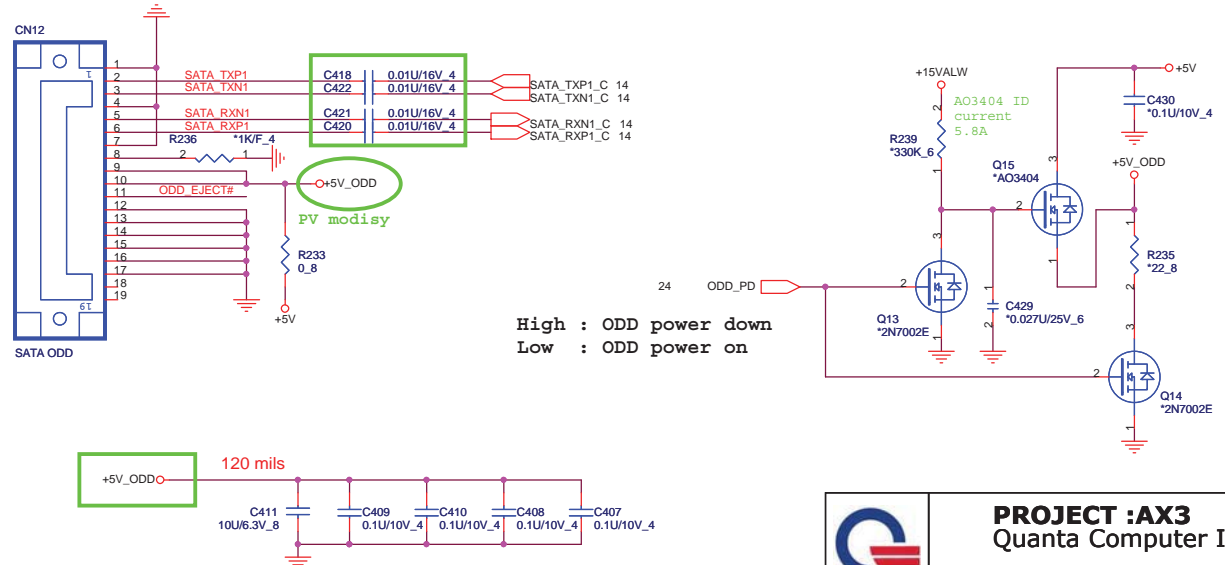

**PROJECT :AX3**  
Quanta Computer Inc.

**NBS5**

Size Custom	Document Number <b>HDD/ODD/FAN</b>	Rev 1A
Date: Friday, November 27, 2009	Sheet 21 of 30	

### BLUETOOTH

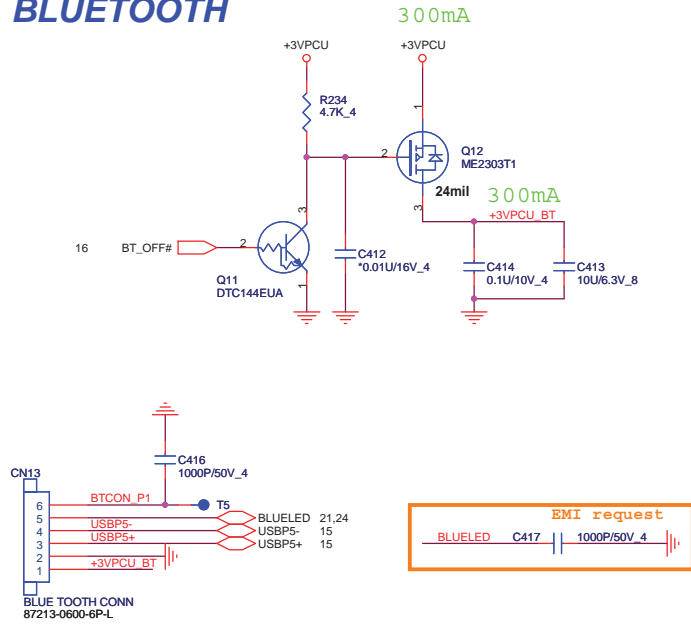

### LEFT SIDE USBX1

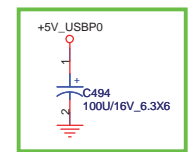
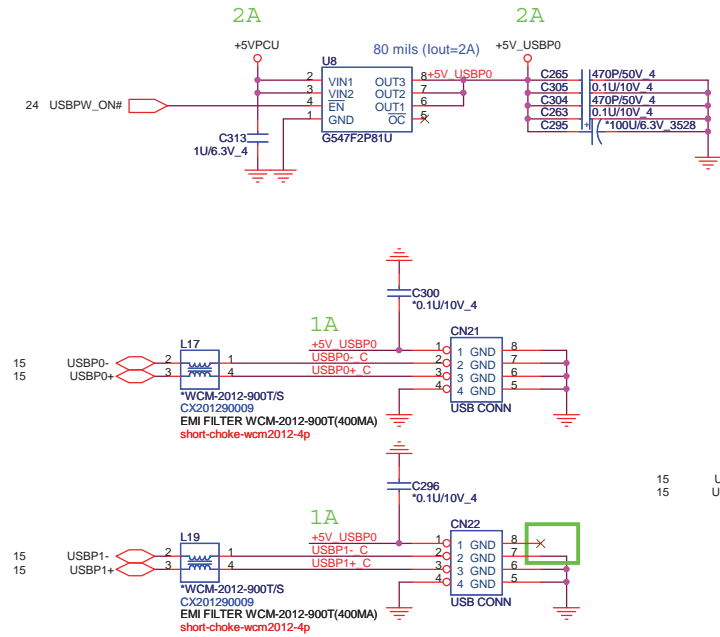

### Right SIDE USBX1

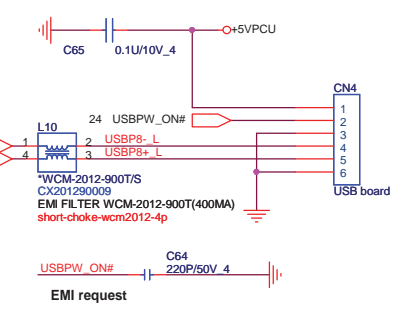

### CAMERA

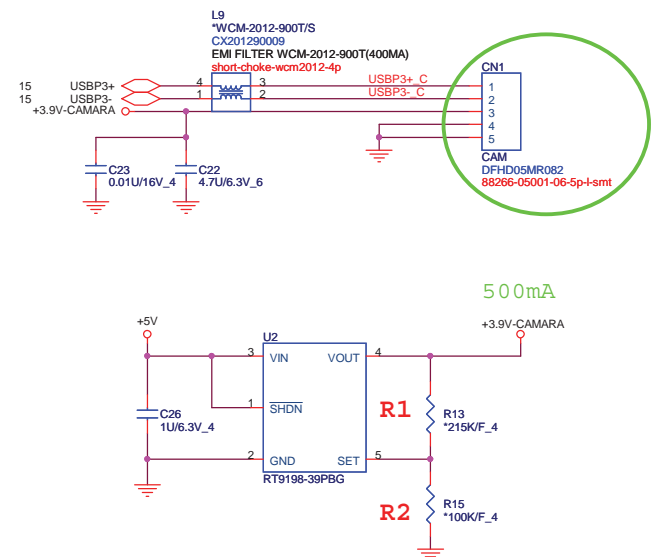

### Modem CONN

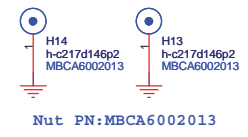
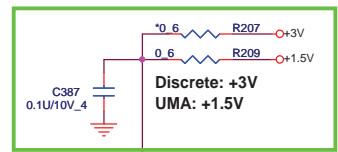
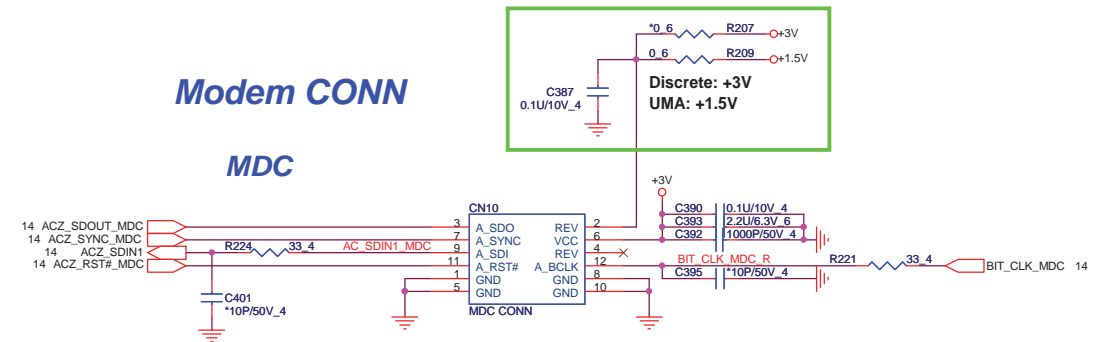

**PROJECT :AX3**  
Quanta Computer Inc.

Size Custom Document Number **USB/BT/CAMERA/Modem** Rev 1A

Date: Friday, November 27, 2009 Sheet 22 of 30

### POWER BOTTON CONNECT

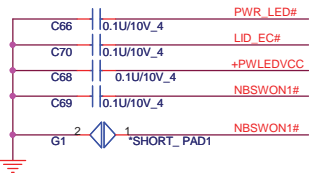
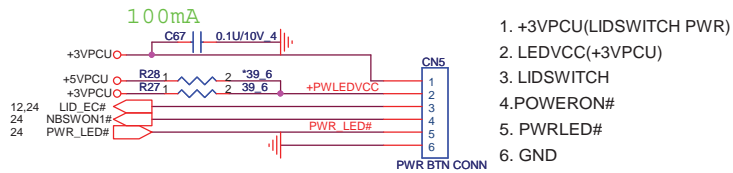

### SATA LED

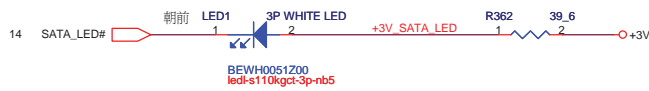

### KEYBOARD Con.

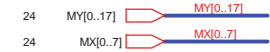
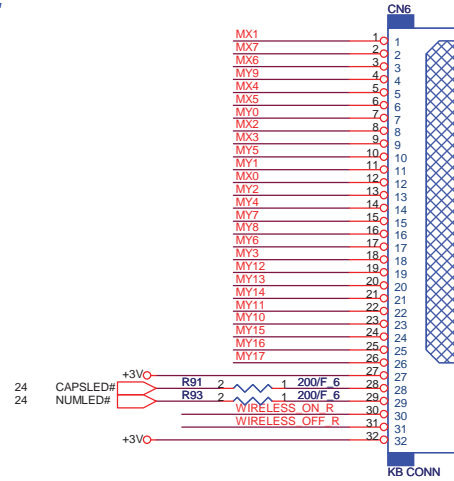
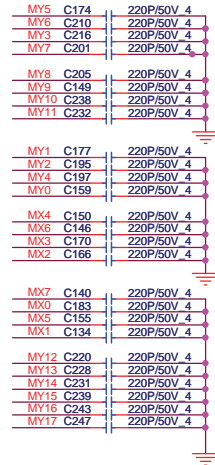

### KEYBOARD PULL-UP

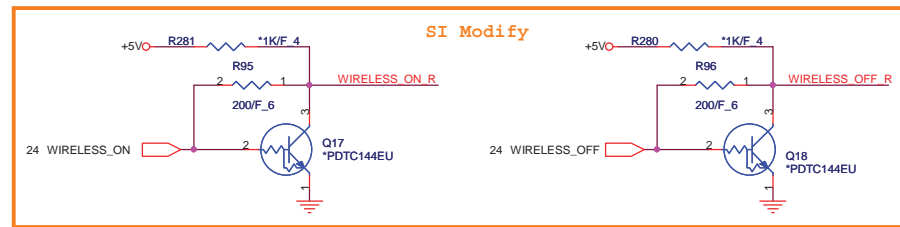
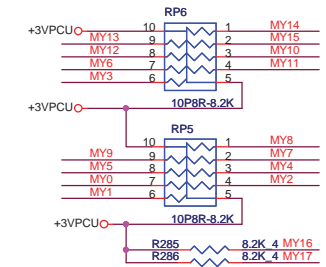

### HOLE & PAD

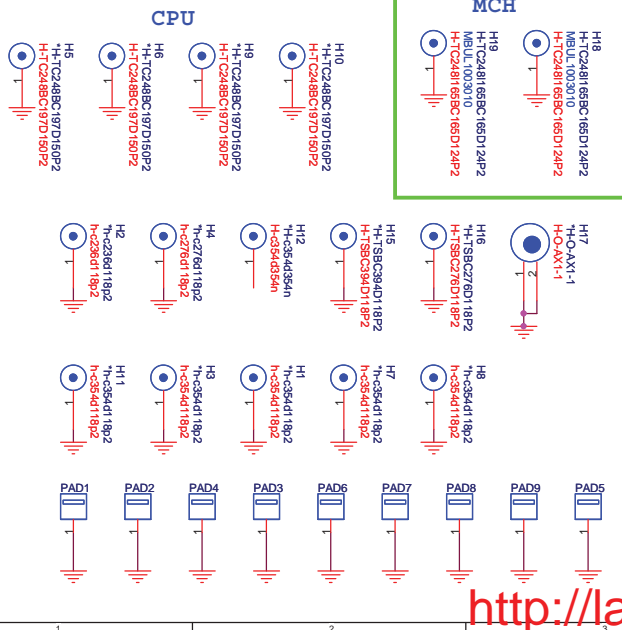

### TOUCH PAD Con.

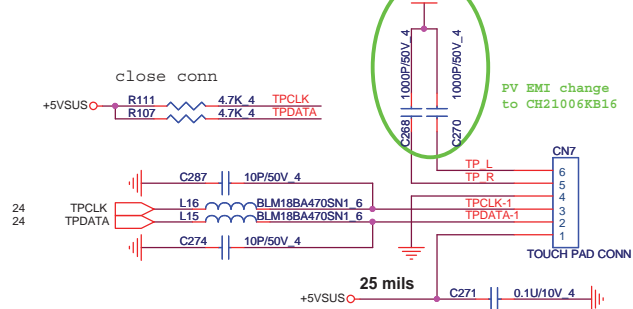

### To TOUCH PAD SW board

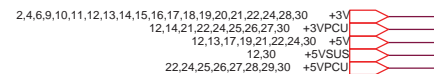
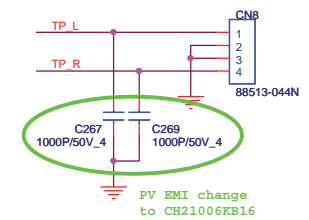



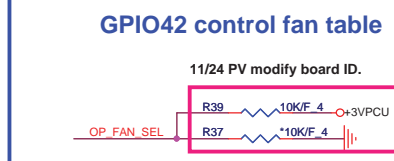
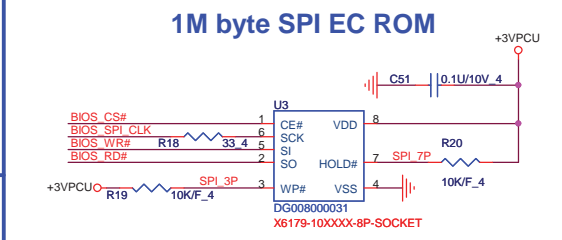
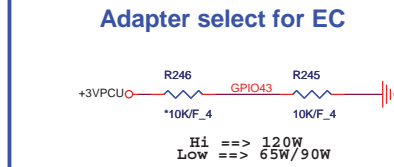
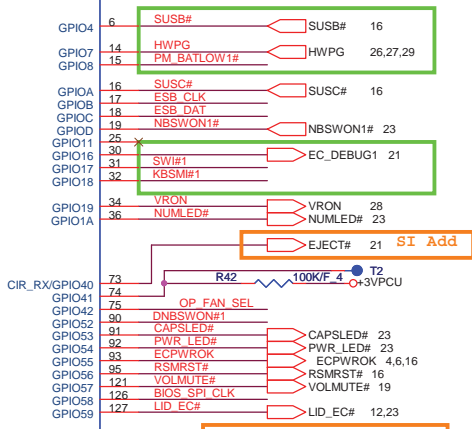
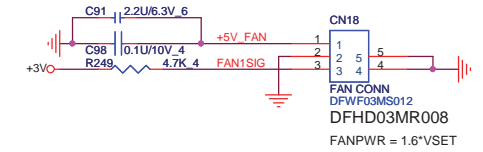
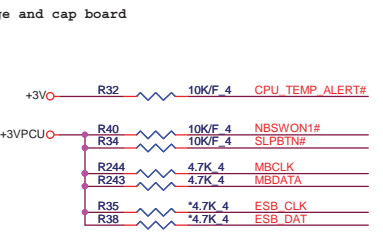
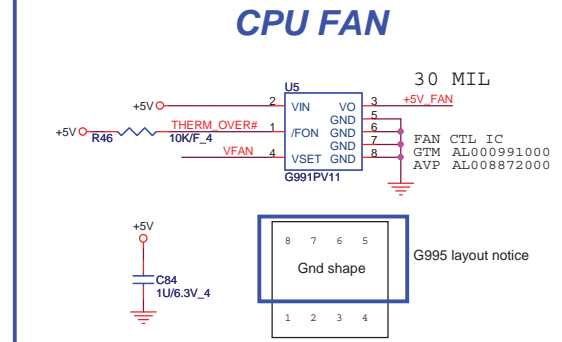
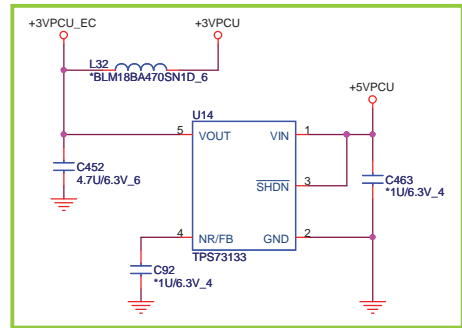
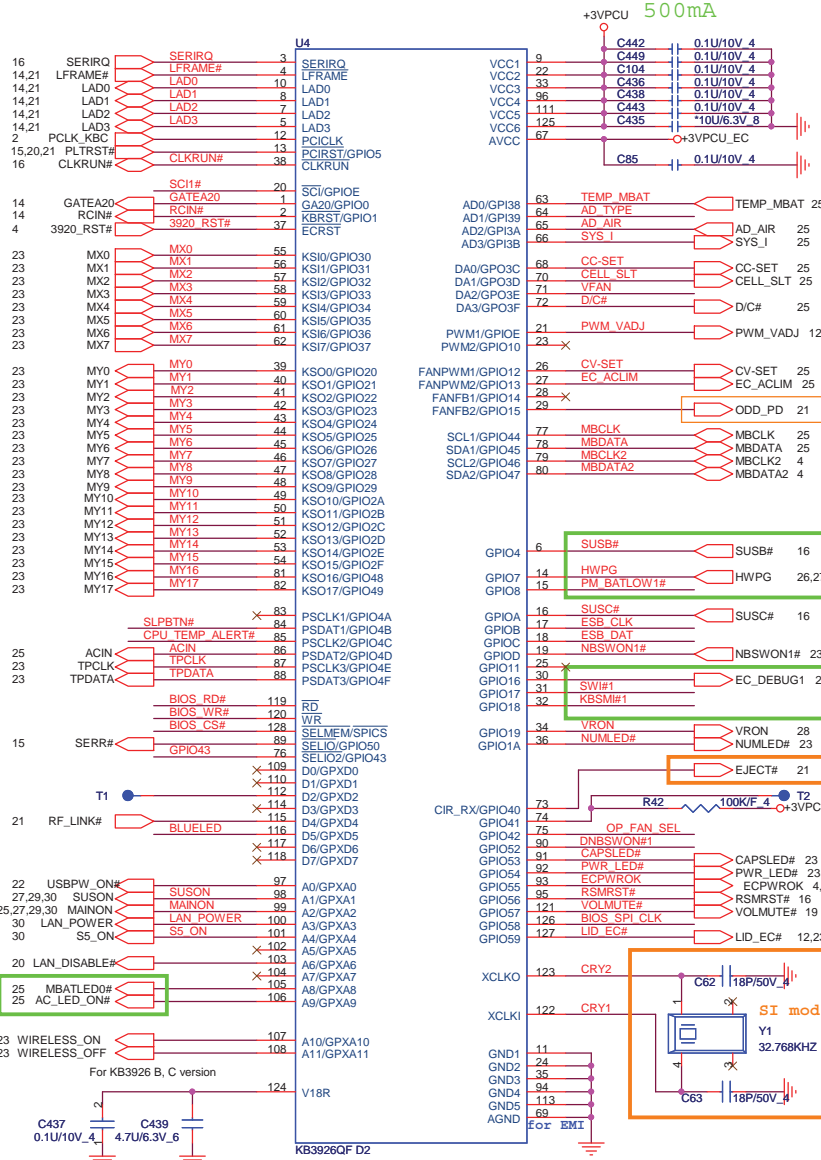

Project Model	GPIO42
AX 14"	High
AX 15.6"	Low
AX 17.3"	Middle (1.5V)

Socket: DG00800031  
 WINBOND AKE3GZNON00  
 EON AKE3GZP0Q00  
 AIT AKE3GZP0801  
 MAX AKE5GFK0Z09

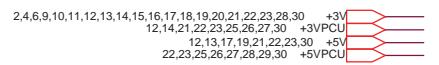
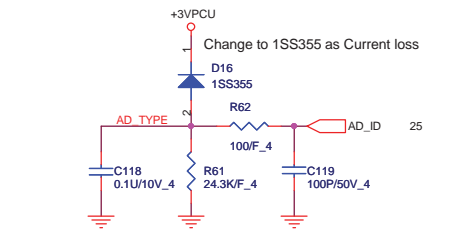
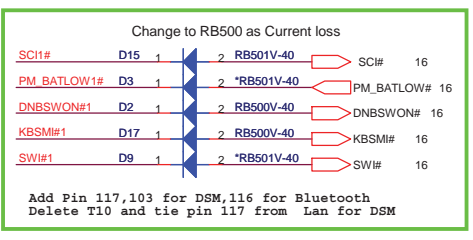

**PROJECT :AX3**  
**Quanta Computer Inc.**

Size Custom Document Number **EC (KB3926)/ROM** Rev 1A  
 Date: Friday, November 27, 2009 Sheet 24 of 30

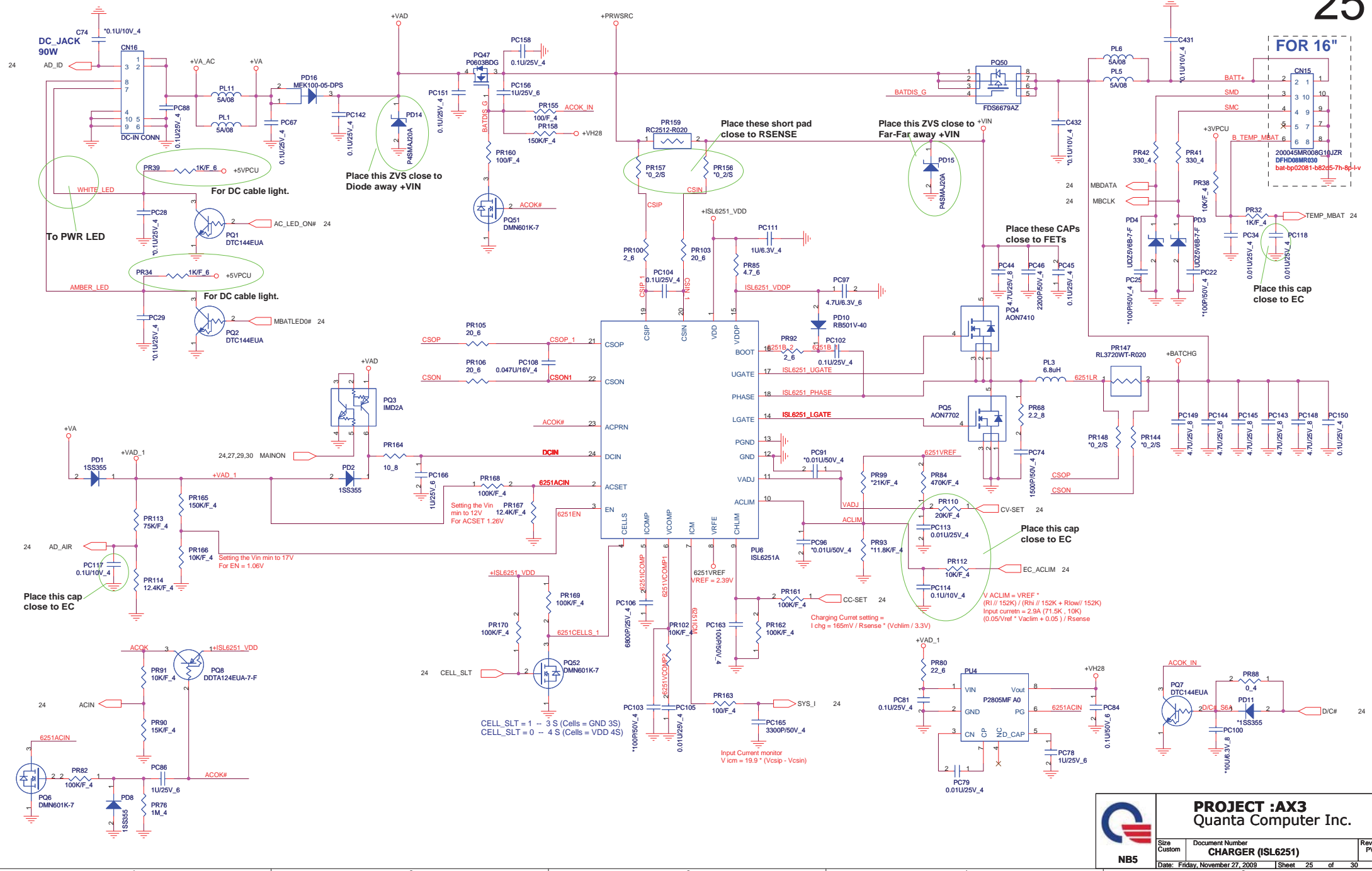

	<b>PROJECT :AX3</b>		Rev PV
	Quanta Computer Inc.		
	Size Custom	Document Number <b>CHARGER (ISL6251)</b>	
Date: Friday, November 27, 2009		Sheet 25 of 30	

+5V +/- 5%  
 Countinue current:6A  
 Peak current :8A  
 OCP minimum :10A

+3.3V +/- 5%  
 Countinue current:5A  
 Peak current:6A  
 OCP minimum 7.5A

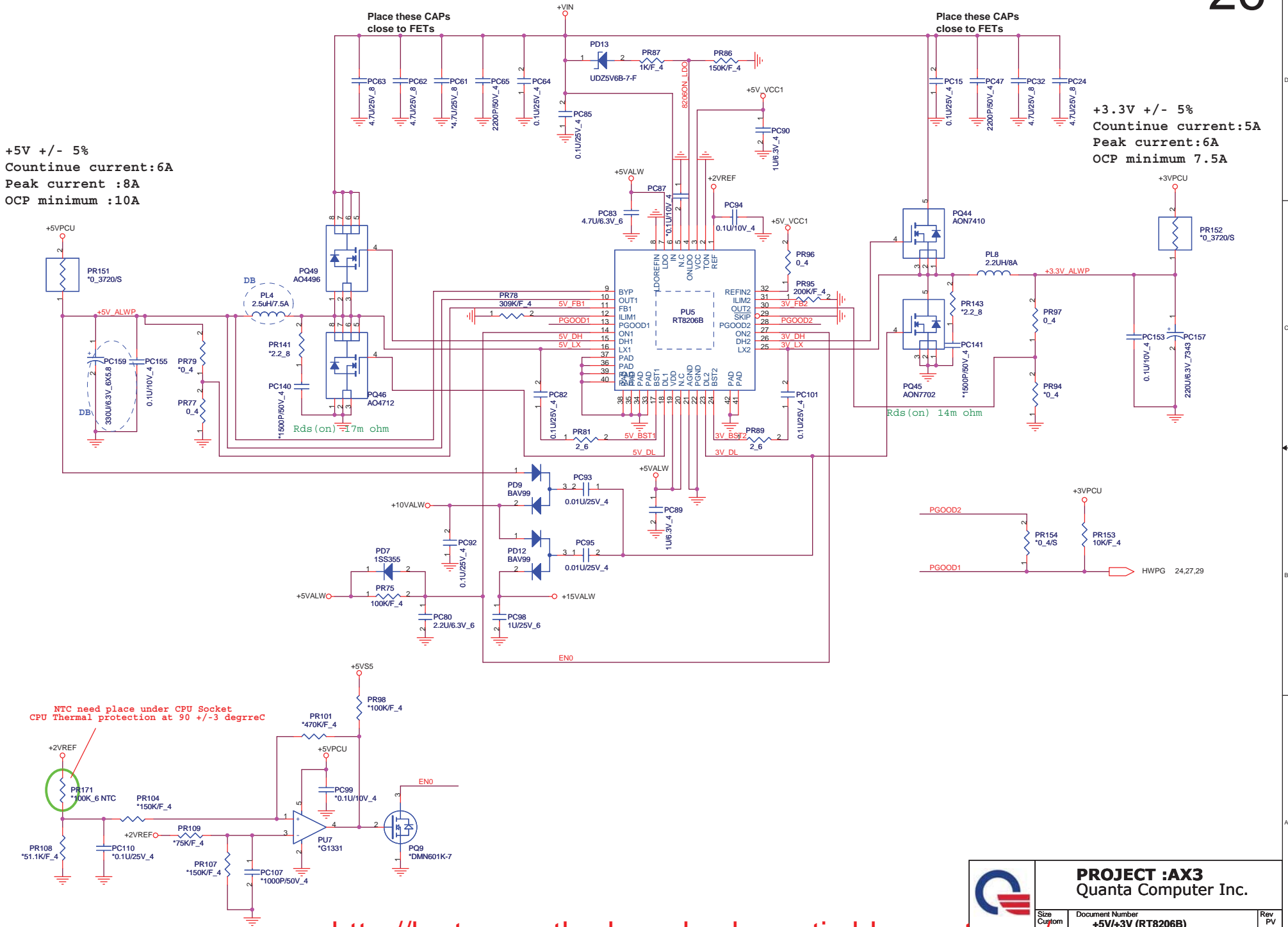

NTC need place under CPU Socket  
 CPU Thermal protection at 90 +/-3 deგრec

 <b>PROJECT :AX3</b> Quanta Computer Inc.		
Size Custom	Document Number <b>+5V/+3V (RT8206B)</b>	Rev PV
Date: Friday, November 27, 2009   Sheet 26 of 30		

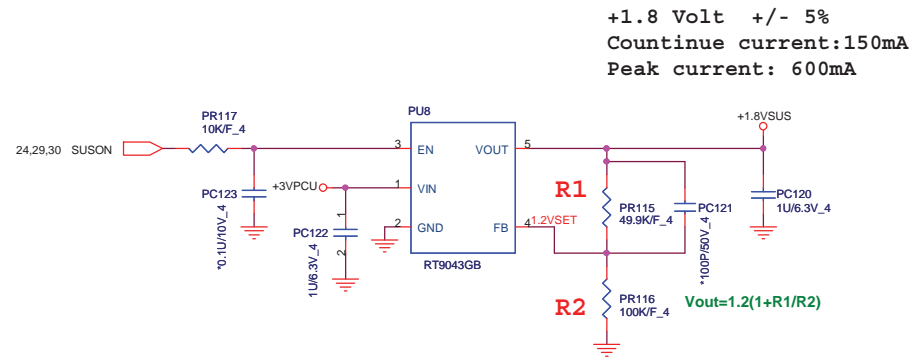
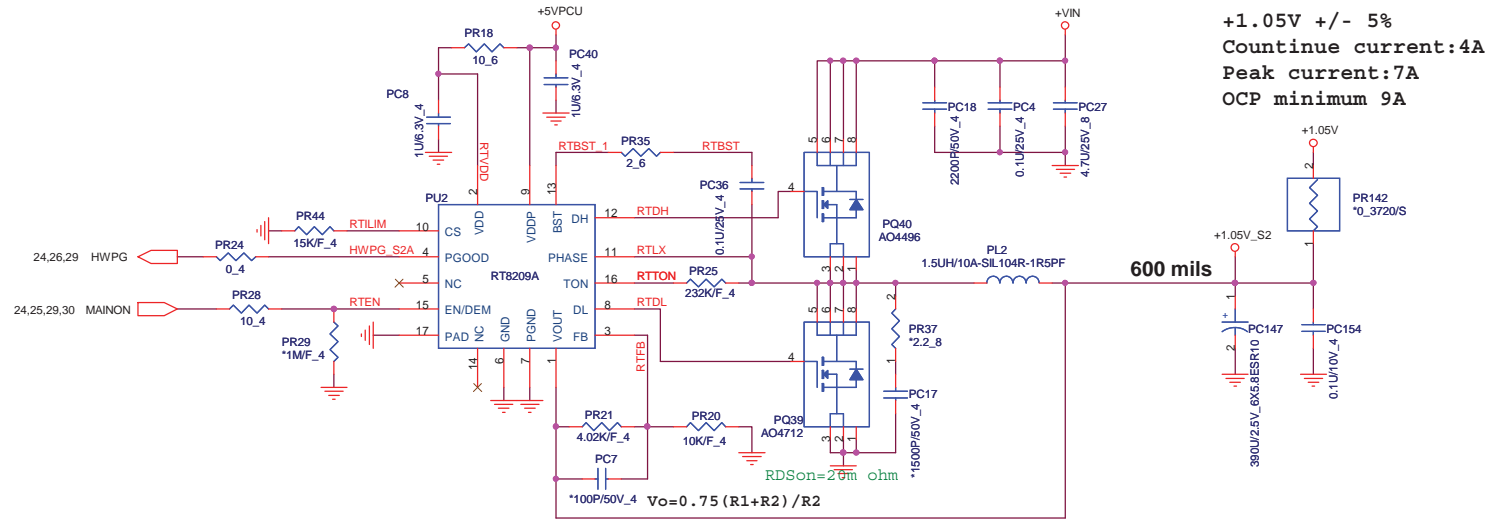

 <b>PROJECT :AX3</b> Quanta Computer Inc.		
Size Custom	Document Number <b>+1.05V/+1.8V (RT8204C)</b>	Rev PV
Date: Friday, November 27, 2009		Sheet 27 of 30

Merom: VCC\_CORE/ 44A  
Yonah: VCC\_CORE/ 36A

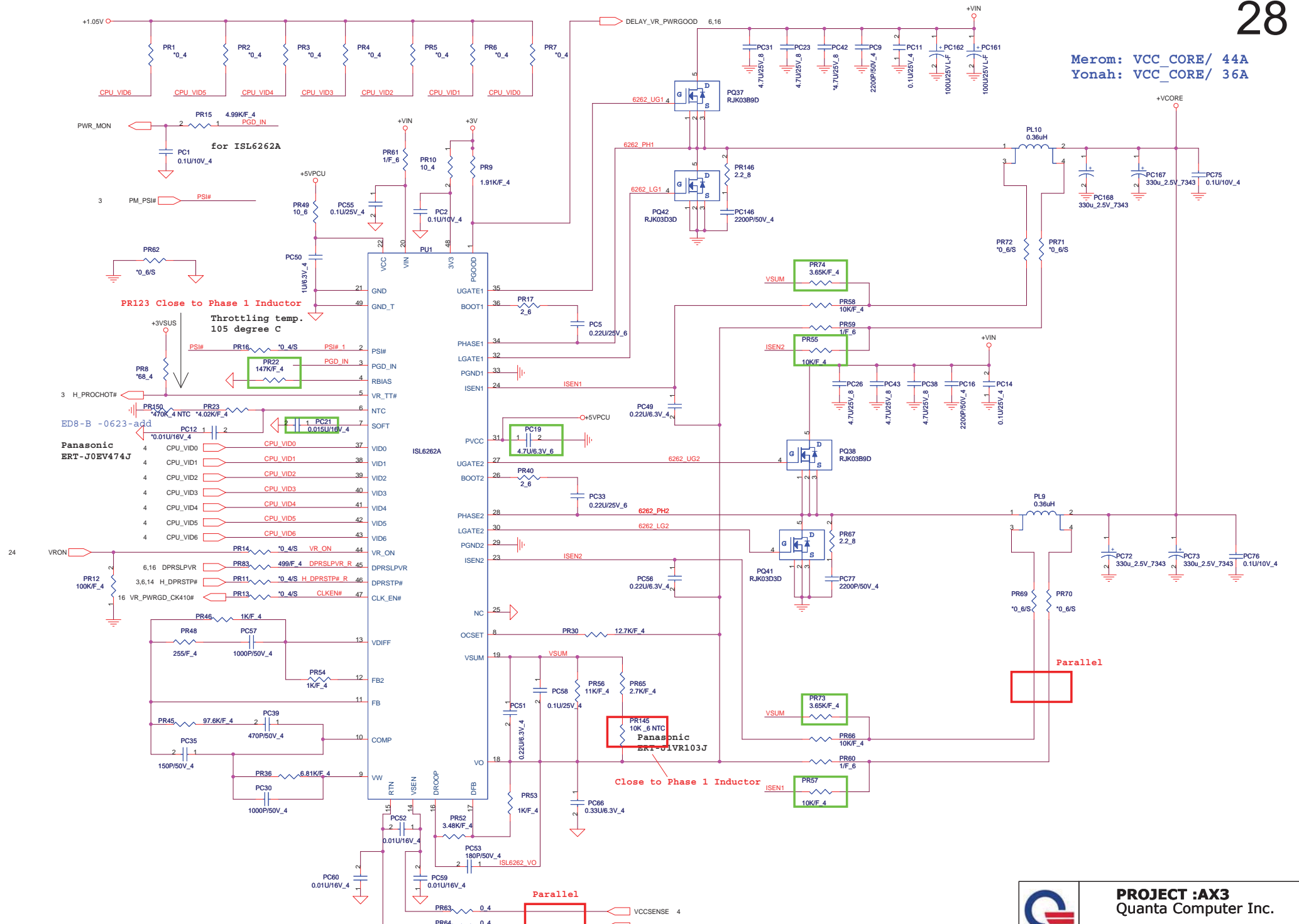

PWR\_MON  
 1 2 3 4 5 6 7 8 9 10 11 12 13 14 15 16 17 18 19 20 21 22 23 24 25 26 27 28 29 30 31 32 33 34 35 36 37 38 39 40 41 42 43 44 45 46 47 48 49 50 51 52 53 54 55 56 57 58 59 60 61 62 63 64 65 66 67 68 69 70 71 72 73 74 75 76 77 78 79 80 81 82 83 84 85 86 87 88 89 90 91 92 93 94 95 96 97 98 99 100

for ISL6262A  
 PC1 0.1U/10V\_4  
 PC2 0.1U/10V\_4  
 PC5 0.1U/25V\_6  
 PC19 4.7U/6.3V\_6  
 PC21 0.015U/16V\_4  
 PC22 147K/F\_4  
 PC23 4.7U/25V\_8  
 PC26 4.7U/25V\_8  
 PC33 0.22U/25V\_6  
 PC35 470P/50V\_4  
 PC38 4.7U/25V\_8  
 PC43 4.7U/25V\_8  
 PC49 0.22U/6.3V\_4  
 PC56 0.22U/6.3V\_4  
 PC58 0.1U/25V\_4  
 PC66 0.33U/6.3V\_4  
 PC72 330u\_2.5V\_7343  
 PC73 330u\_2.5V\_7343  
 PC75 0.1U/10V\_4  
 PC76 0.1U/10V\_4

PR123 Close to Phase 1 Inductor  
 Throttling temp.  
 105 degree C

Panasonic  
 ERT-J0EV474J

Panasonic  
 ERT-J1VR103J

Parallel

Close to Phase 1 Inductor

Parallel

	<b>PROJECT :AX3</b>	
	Quanta Core Inc.	
Size Custom	Document Number	Rev PV
	<b>CPU Core ( ISL6266A )</b>	
Date: Friday, November 27, 2009	Sheet 28 of 30	

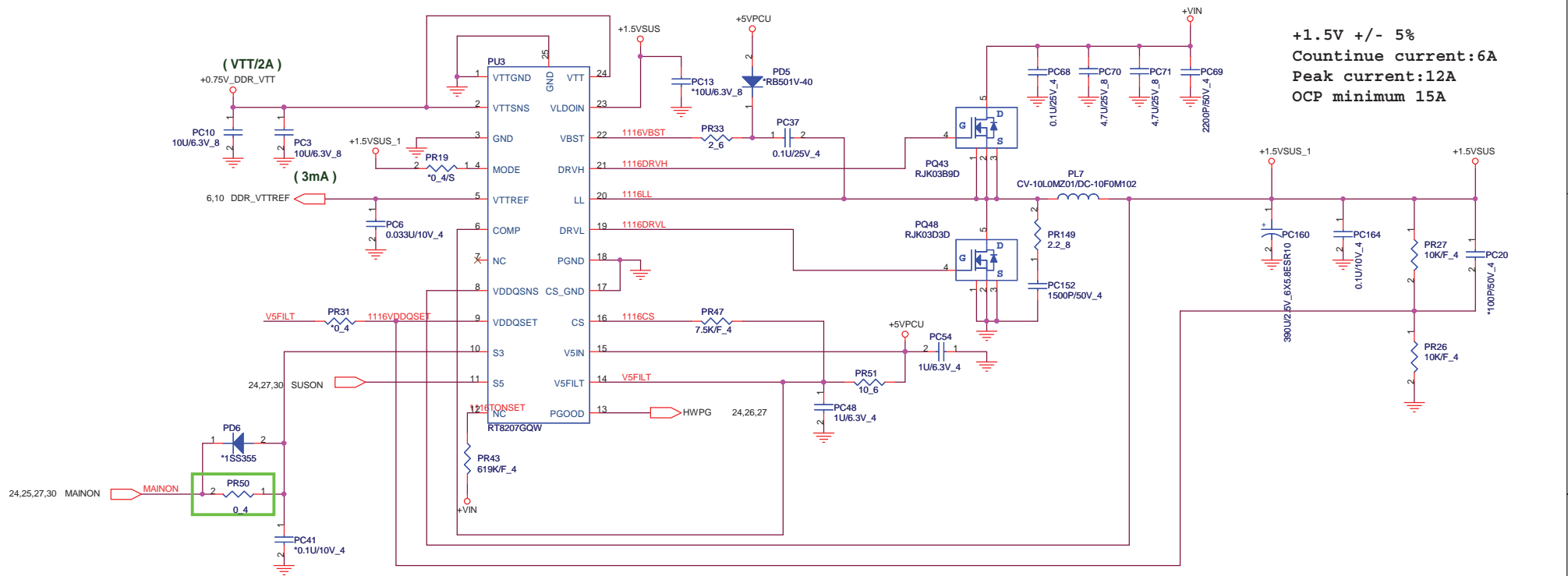

+1.5V +/- 5%  
 Countinue current:6A  
 Peak current:12A  
 OCP minimum 15A

			<b>PROJECT :AX3</b> Quanta Computer Inc.	
Size Custom	Document Number <b>DDR3 (RT8207)</b>	Rev PV		
Date: Friday, November 27, 2009		Sheet 29	of 30	



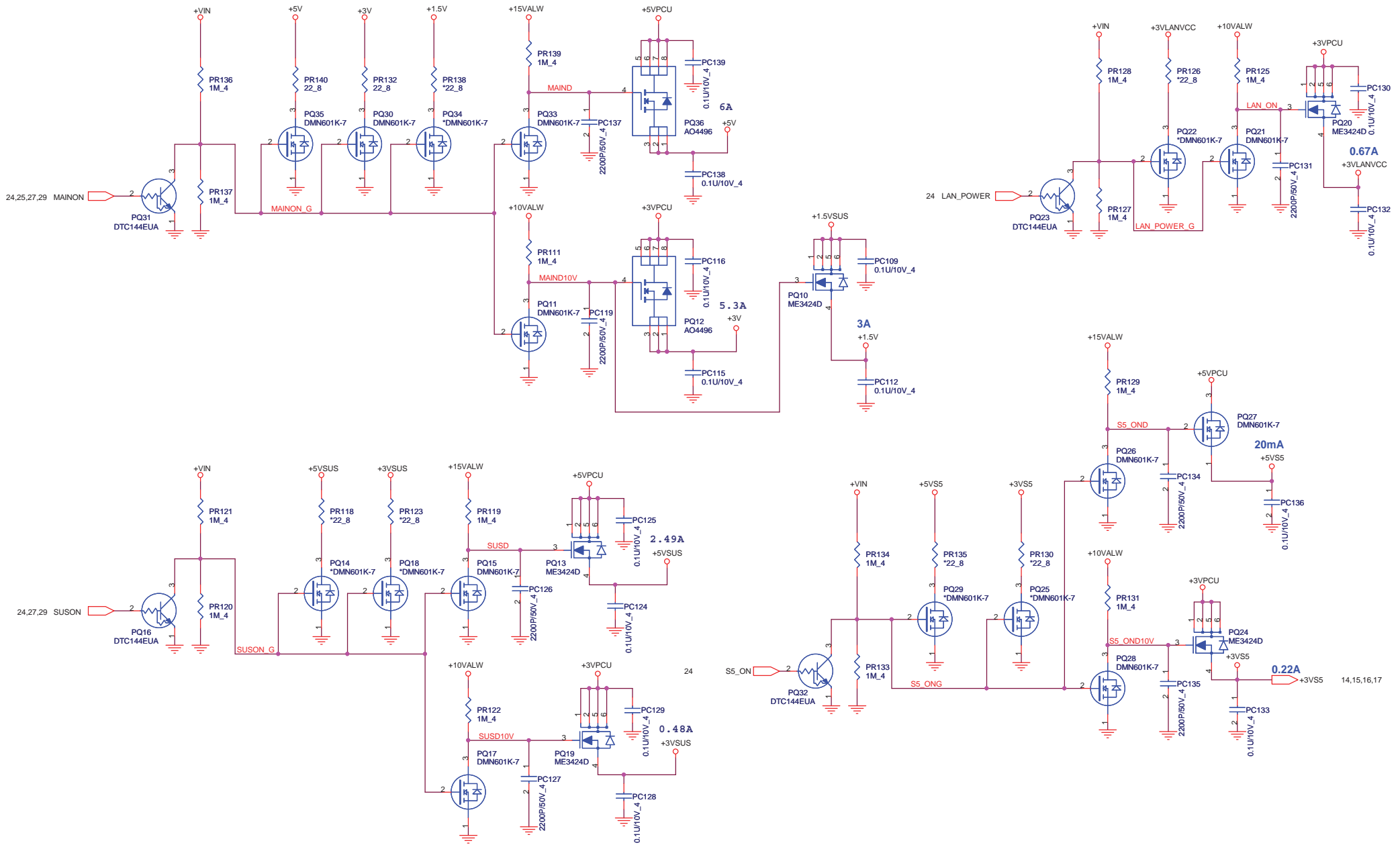

 <p>NBS</p>	<p><b>PROJECT :AX3</b> Quanta Computer Inc.</p>	
	<p>Size Custom</p>	<p>Document Number <b>DISCHARGE/3VS5/5VS5/LAN</b></p>
<p>Date: Friday, November 27, 2009</p>		<p>Sheet 30 of 30</p>