



**TABLE OF CONTENTS**

<b>PAGE</b>	<b>PAGE</b>	<b>PAGE</b>
1.COVER PAGE	32.S/B ICH7 1	56.LINE IN & LINE OUT
2.INDEX	33.S/B ICH7 2	57.MDC 1.5 CONN
3.BLOCK DIAGRAM	34.S/B ICH7 3	58.DOCKING 1
4.POWER SEQUENCE BLOCK	35.S/B ICH7 4	59.DOCKING 2
5-12.SYSTEM POWER	36.S/B ICH7 5	60.SWITCH & LED (MB)
13.CLOCK GENERATOR	37.CARDBUS CONTROLLER	61.SWITCH & LED (DB)
14.CPU Yonah1	38.PCMCIA & EXPRESS CARD	62.PICK BUTTON BOARD
15.CPU Yonah2	39.5 IN 1 CARD SLOT	63.PARALLEL PORT BOARD
16.CPU Yonah3	40.1394 CONTROLLER	64.USB BOARD
17.CPU Yonah4	41.LAN CONTROLLER-1	65.DRILL HOLE
18.FAN & THERMAL CONTROLLER	42.LAN CONTROLLER-2	
19.N/B Calistoga 1	43.RJ45 & TRANSFORMER	
20.N/B Calistoga 2	44.MINI CARD CONN	
21.N/B Calistoga 3	45.3D Sensor & SATA HDD CONN	
22.N/B Calistoga 4	46.ODD CONN	
23.N/B Calistoga 5	47.USB CONN	
24.N/B Calistoga 6	48.BLUE TOOTH CONN	
25.DDR2 DIMM0	49.TPM 1.2	
26.DDR2 DIMM1	50.SUPER I/O	
27.DDR DAMPING	51.Serial & Parallel port CONTROLLER	
28.VGA CONN	52.K/B & D/B CONN	
29.CRT CONN	53.CIR & FIR	
30.SVIDEO CONN	54.AZALIA CODEC	
31.LCD CONN	55.AUDIO AMP & MIC & HP	

**INVENTEC**

TITLE *San Antonio 10*

SIZE	CODE	DOC. NUMBER	REV
A3	CS	TC8703	A03

SHEET 2 OF 65

CHANGE by *Drawer Name* 28-Nov-2005

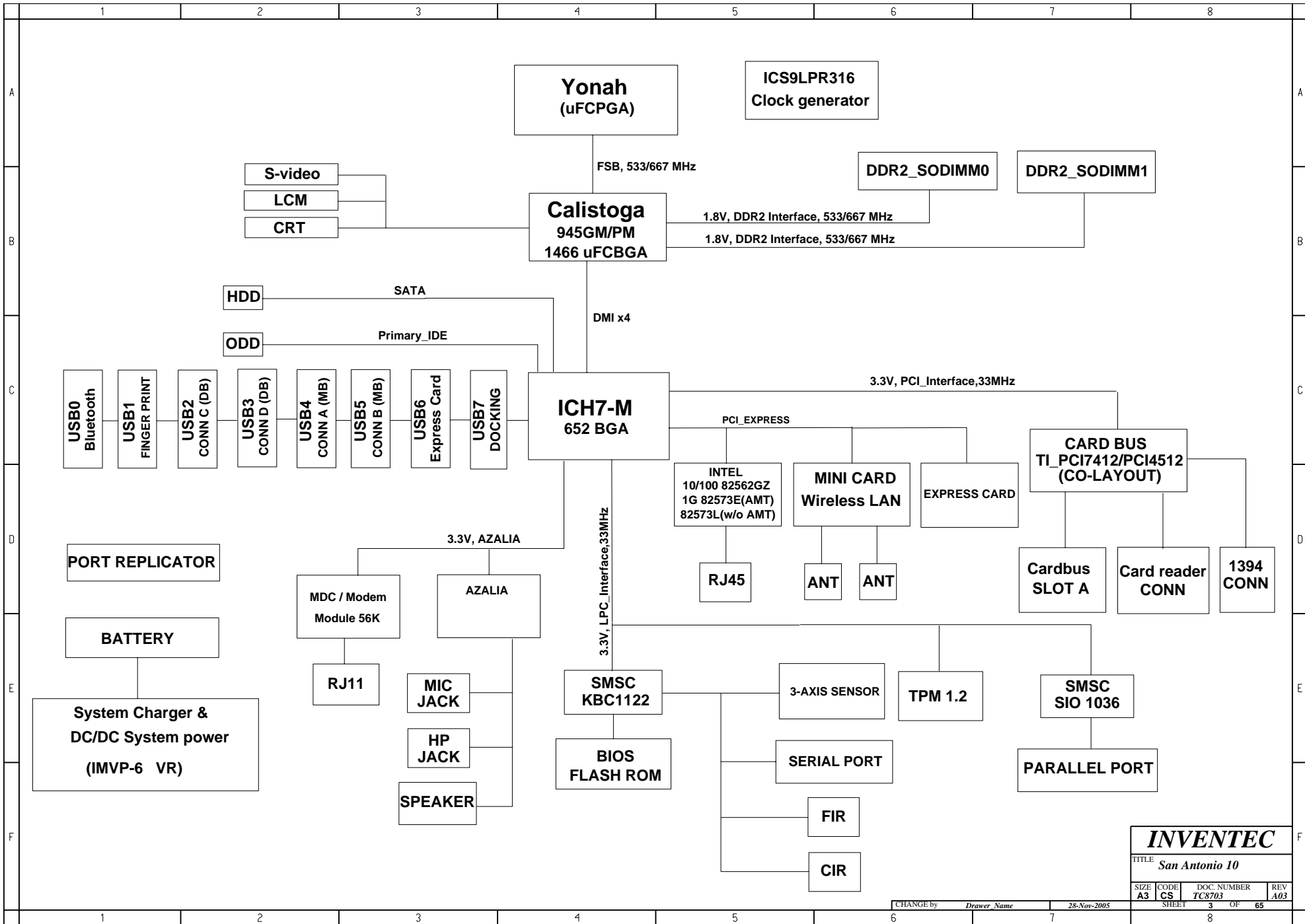

<b>INVENTEC</b>			
TITLE <i>San Antonio 10</i>			
SIZE A3	CODE CS	DOC. NUMBER TC8703	REV A03

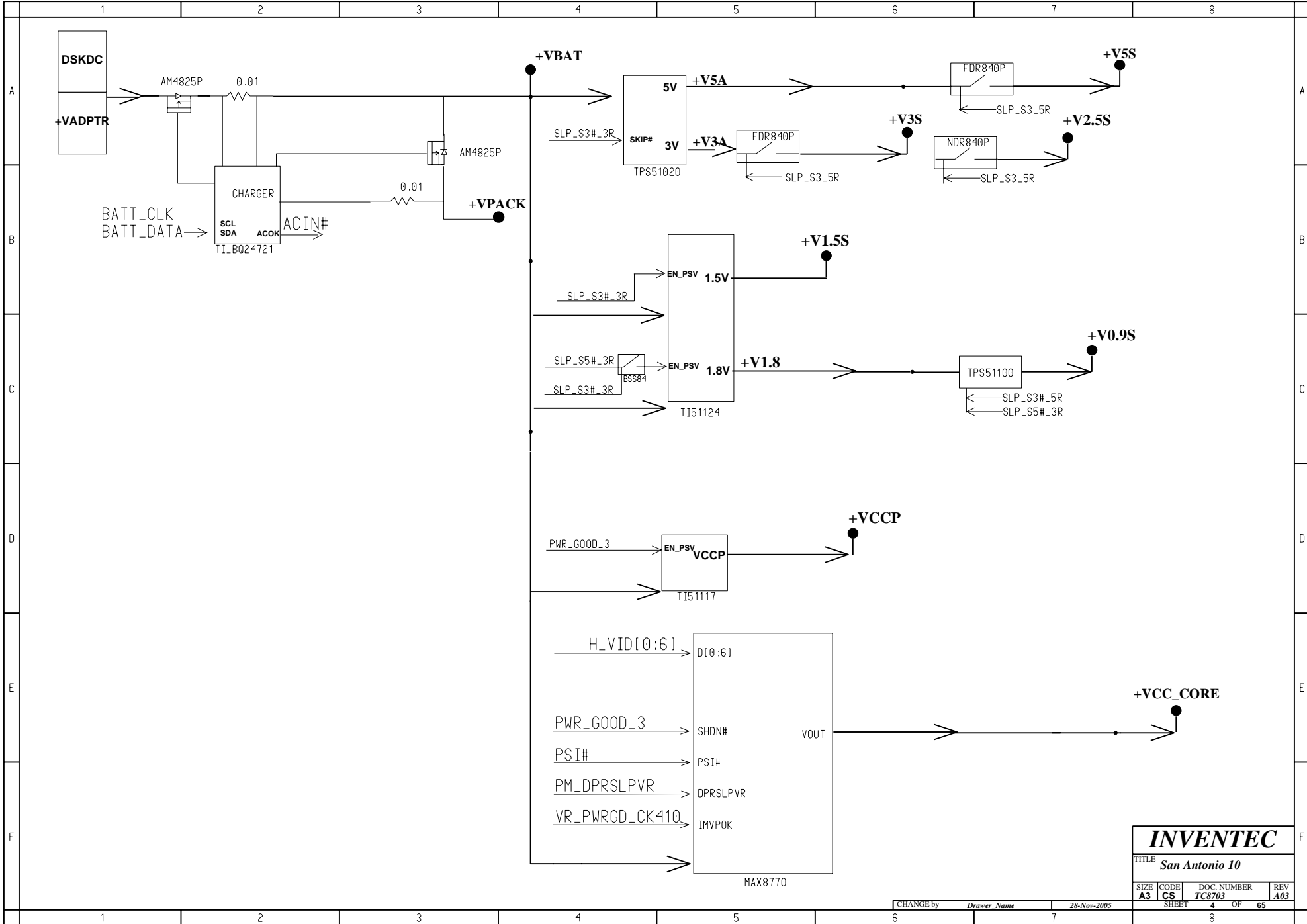

<b>INVENTEC</b>			
TITLE <b>San Antonio 10</b>			
SIZE <b>A3</b>	CODE <b>CS</b>	DOC. NUMBER <b>TC8703</b>	REV <b>A03</b>
CHANGE by <i>Drawer Name</i>		28-Nov-2005	
SHEET		4 OF 65	
8		8	

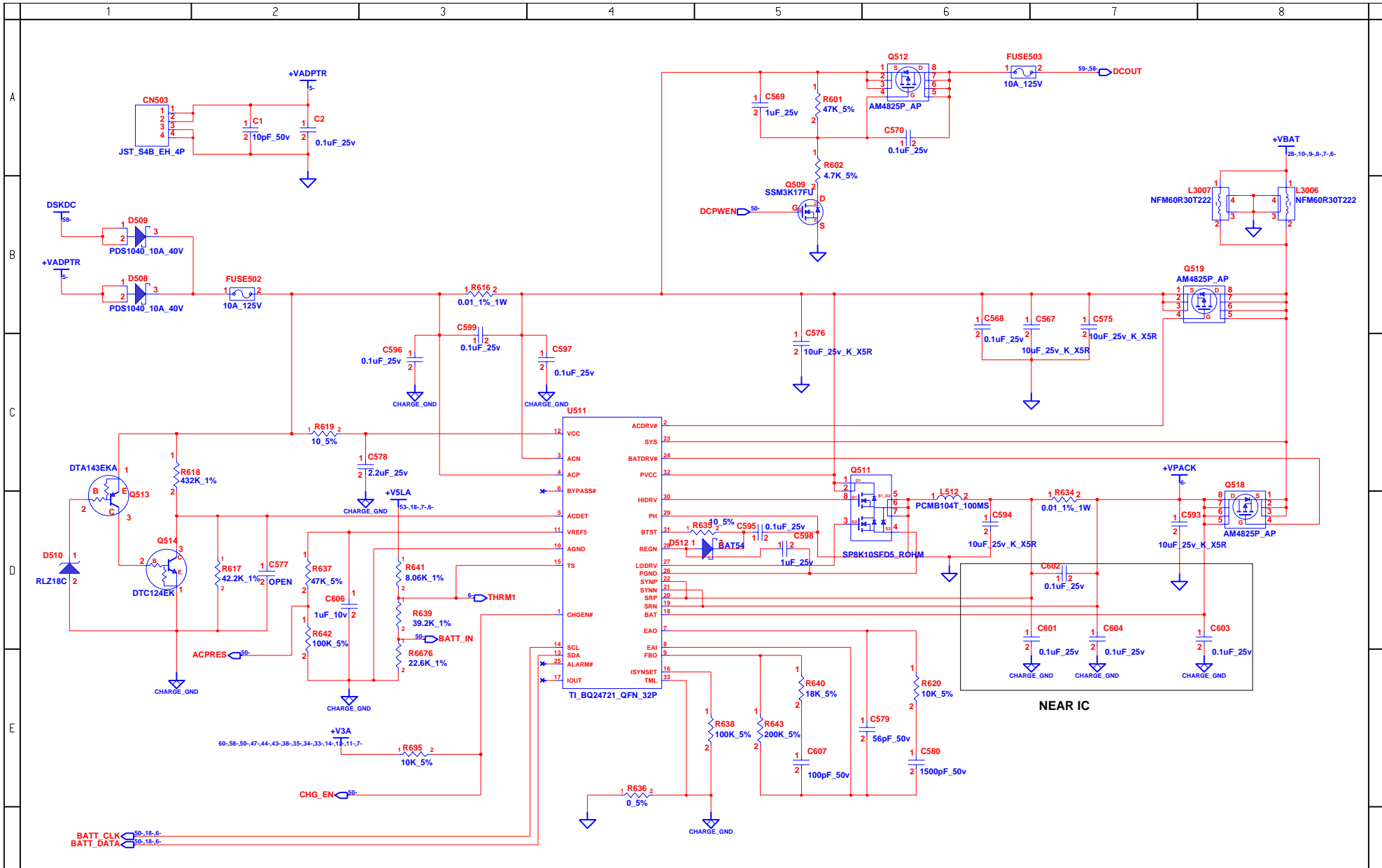

<b>INVENTEC</b>			
TITLE: <b>San Antonio 10 DC &amp; BATTERY CHARGER</b>			
SIZE: <b>A3</b>	CODE: <b>CS</b>	DOC. NUMBER: <b>TC8703</b>	REV: <b>A03</b>
DRAWER NAME		1-Dec-2005	
SHEET		5 OF 65	
		8	

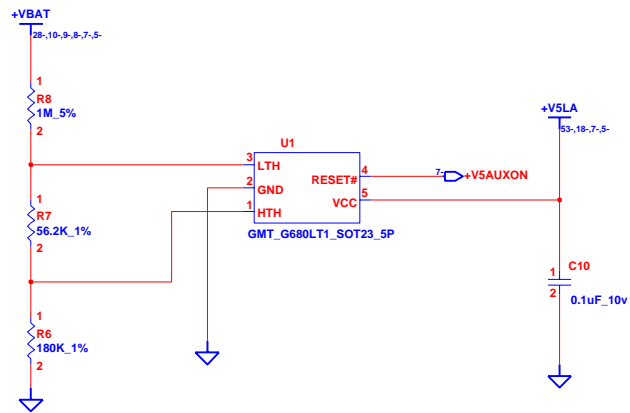
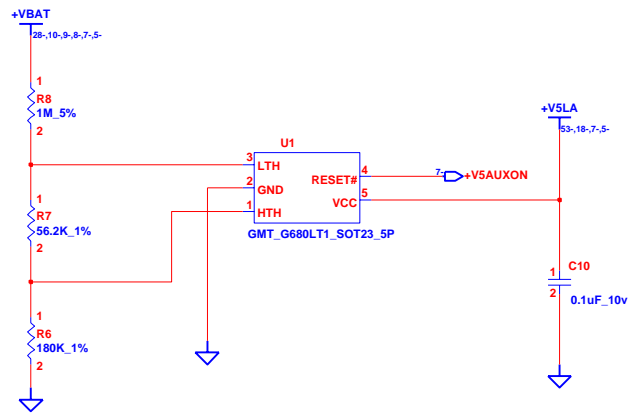
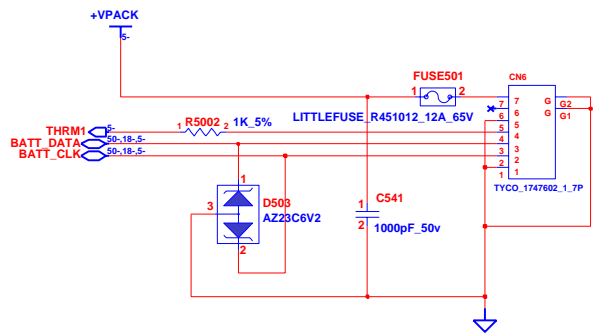

# INVENTEC

TITLE			
San Antonio 10 BATTERY CONN			
SIZE	CODE	DOC. NUMBER	REV
A3	CS	TC8703	A03

CHANGE by *Drawer Name* 28-Nov-2005

SHEET 6 OF 65

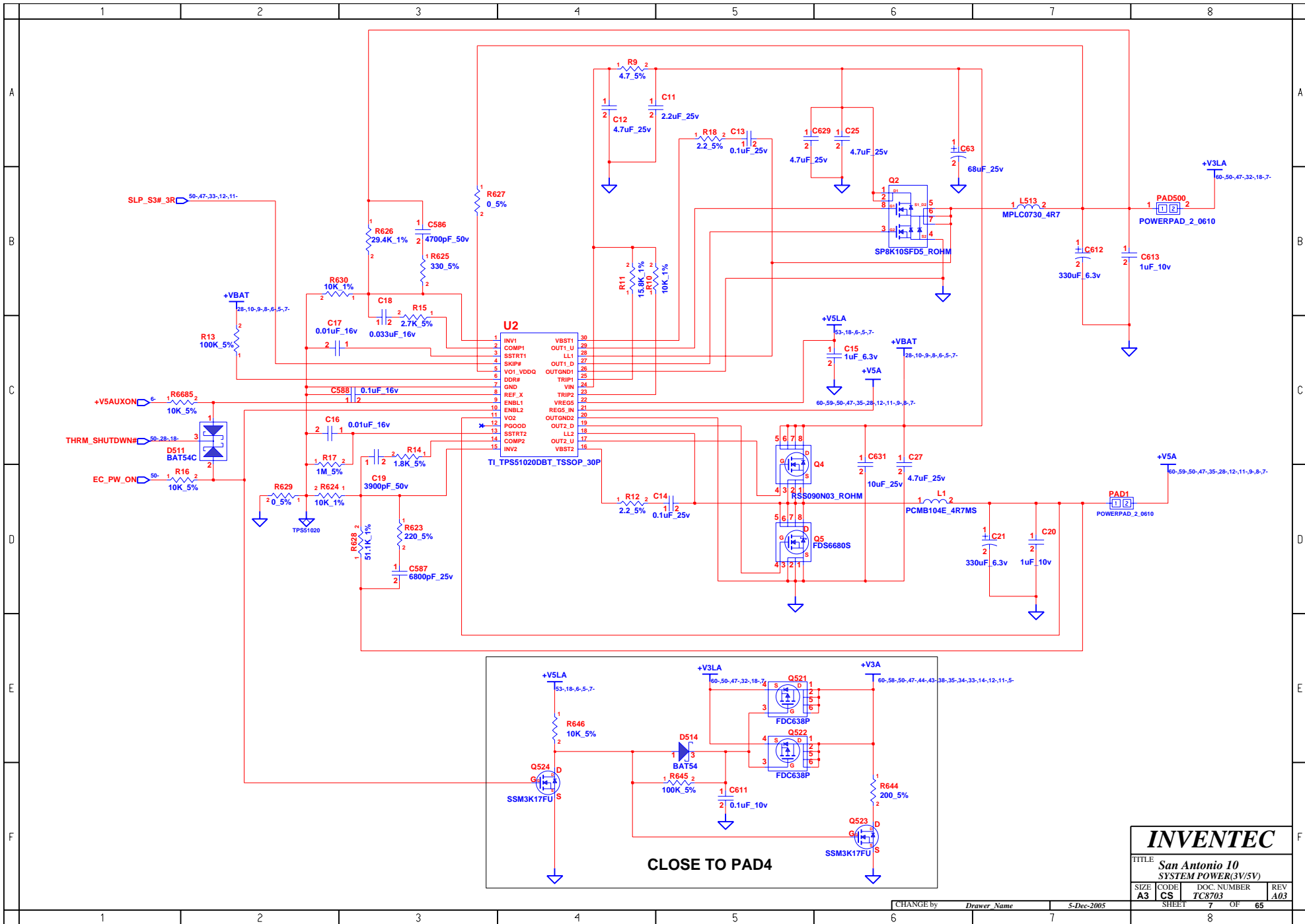

<b>INVENTEC</b>			
TITLE: <b>San Antonio 10</b>			
SYSTEM POWER(3V/5V)			
SIZE	CODE	DOC NUMBER	REV
A3	CS	TC8703	A03
CHANGE by		Drawer Name	5-Dec-2005
SHEET		7	OF 65









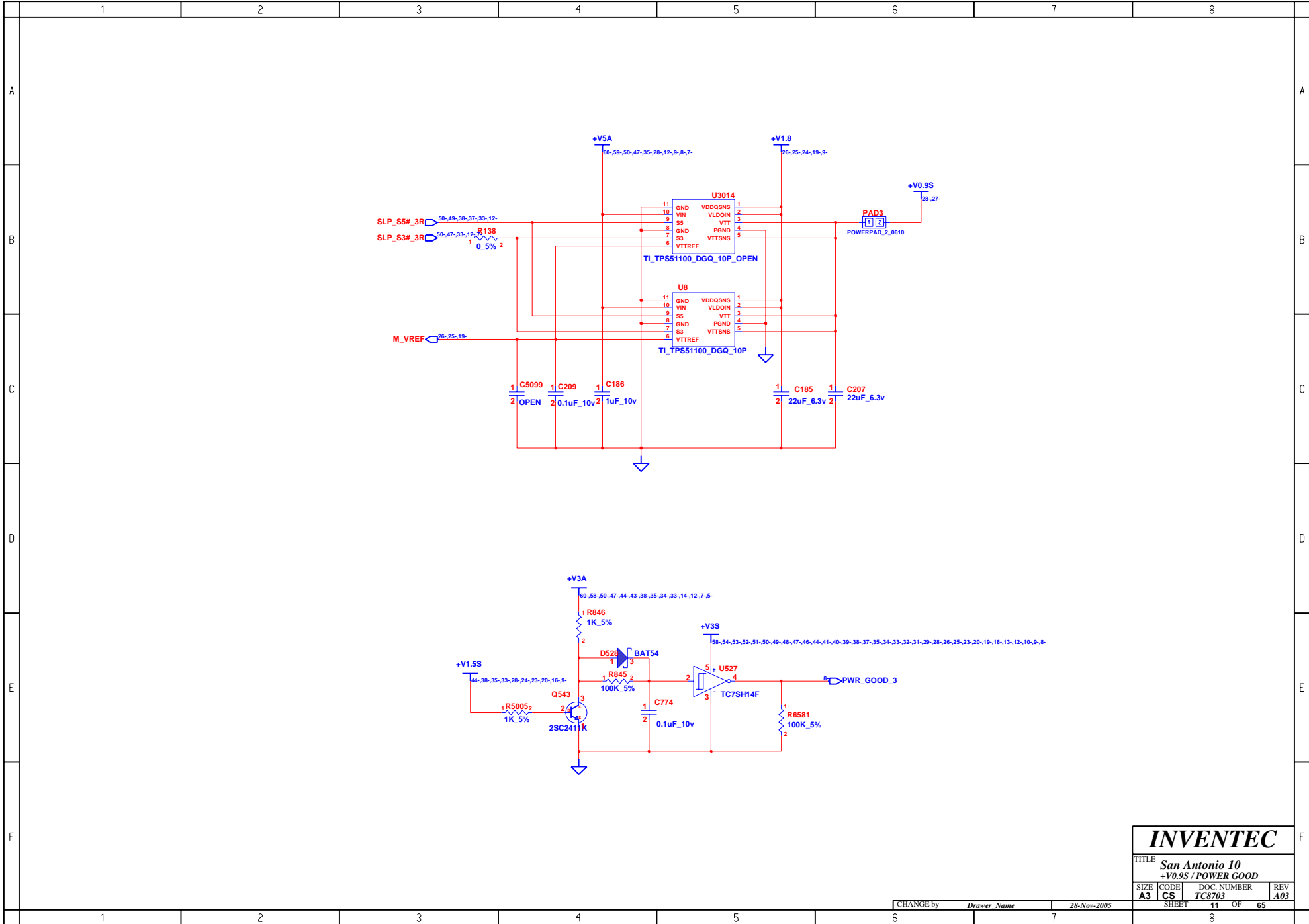

**INVENTEC**

TITLE **San Antonio 10**  
**+V0.9S / POWER GOOD**

SIZE	CODE	DOC. NUMBER	REV
A3	CS	TC8703	A03

CHANGE by *Drawer Name* 28-Nov-2005

SHEET 11 OF 65

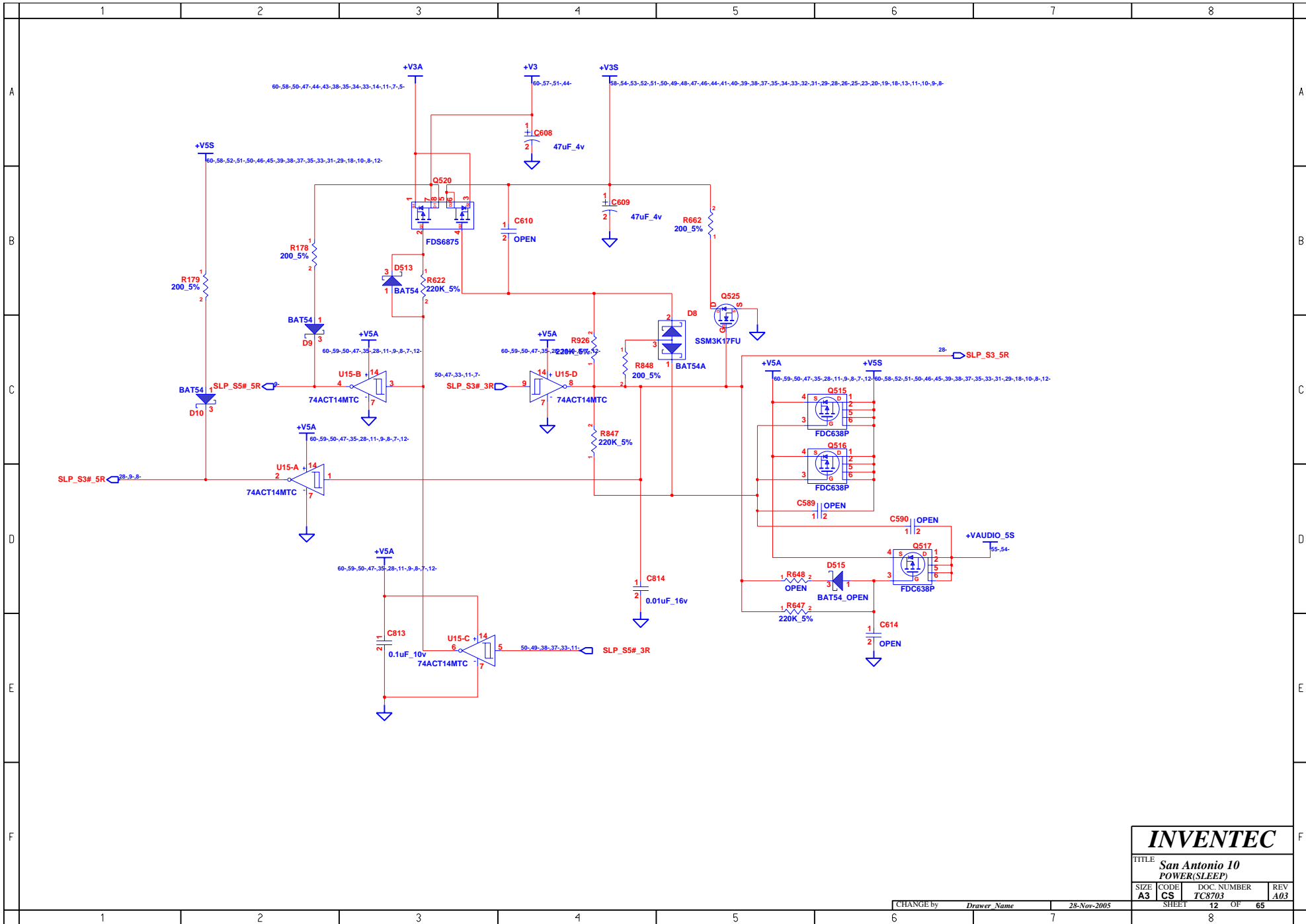

# INVENTEC

TITLE			
San Antonio 10 POWER(SLEEP)			
SIZE	CODE	DOC. NUMBER	REV
A3	CS	TC8703	A03

CHANGE by	Drawer Name	28-Nov-2005	SHEET	12	OF	65
-----------	-------------	-------------	-------	----	----	----

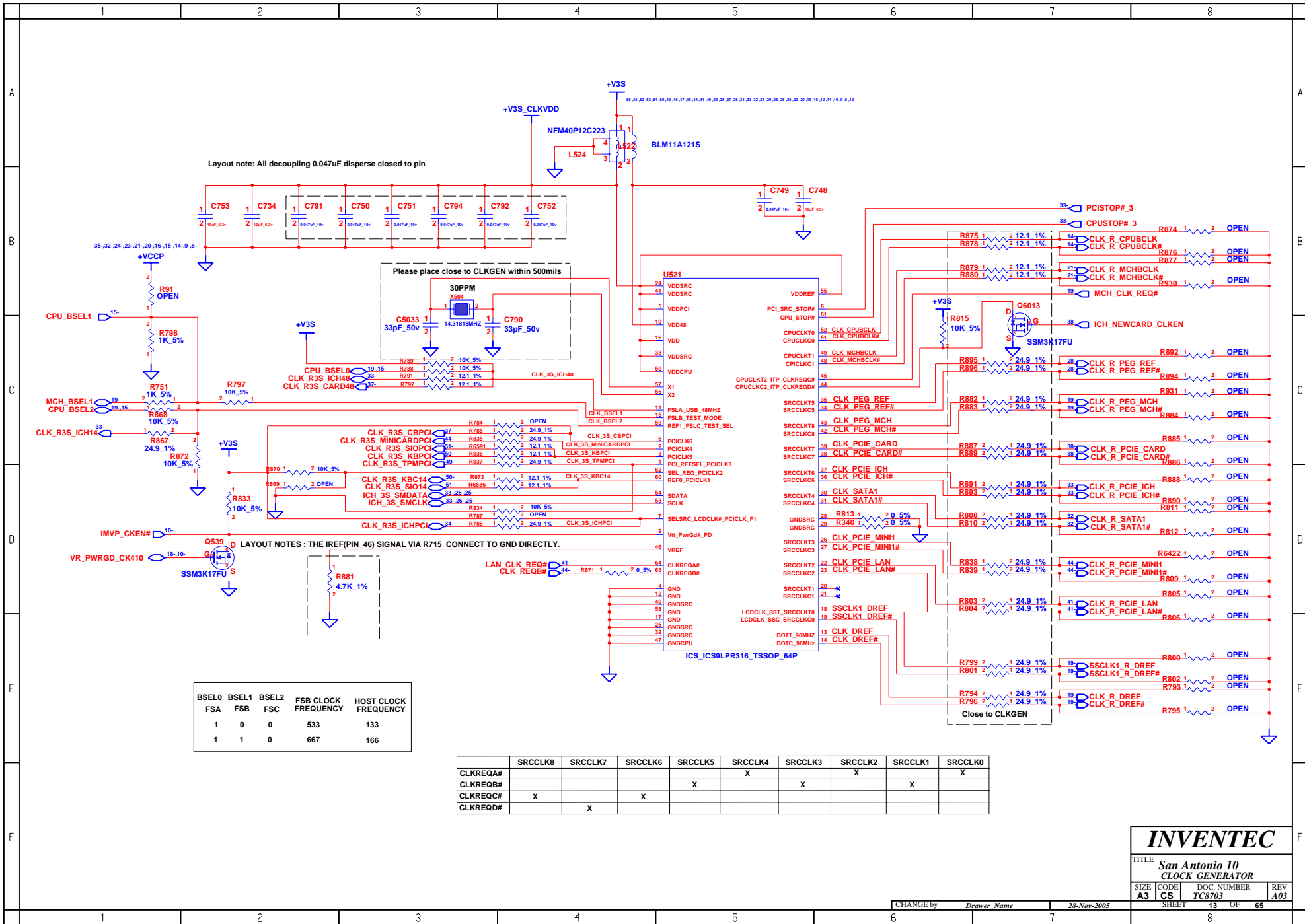

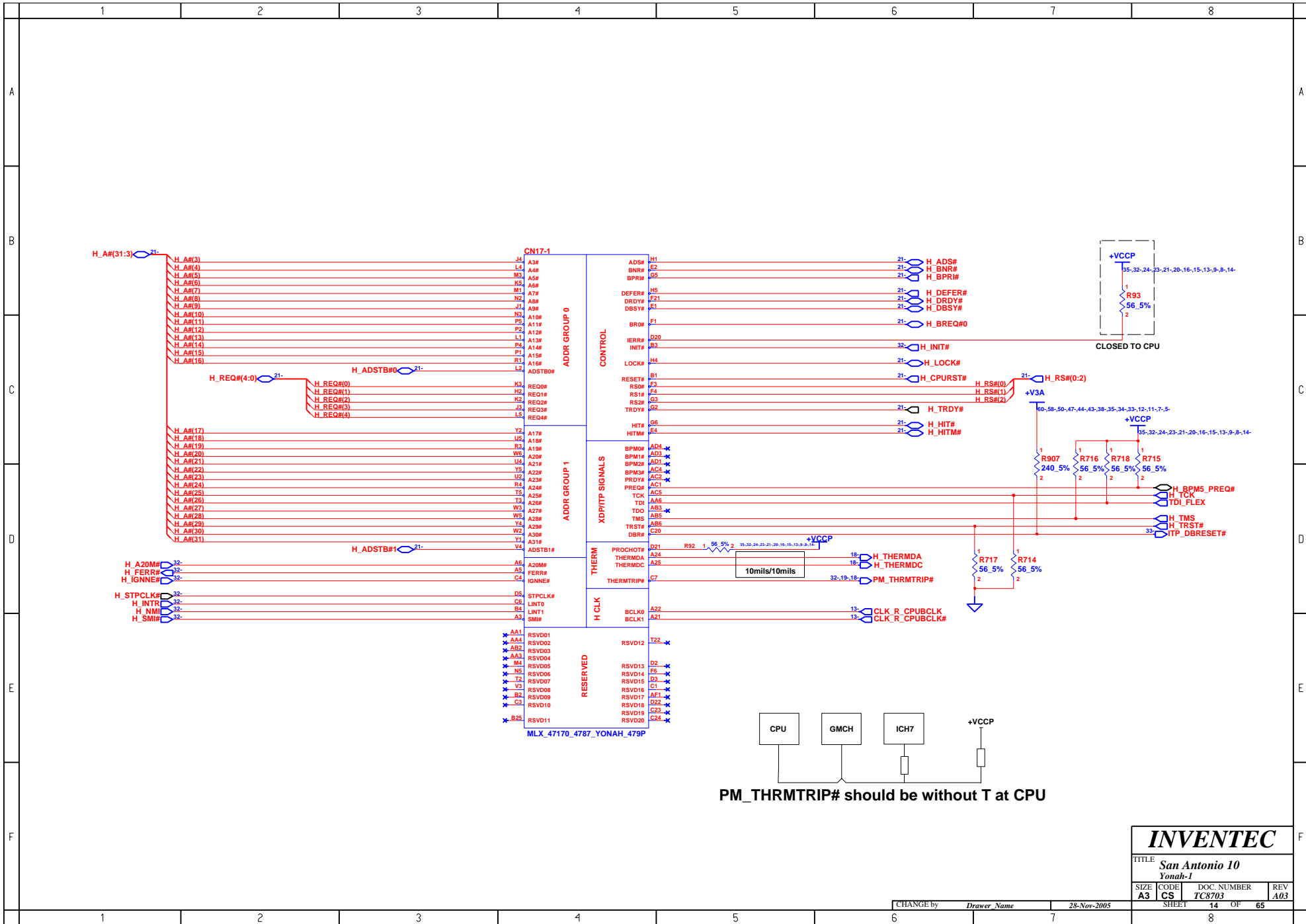

<b>INVENTEC</b>			
TITLE: San Antonio 10			
Yonah-1			
SIZE	CODE	DOC. NUMBER	REV
A3	CS	TC8703	A03

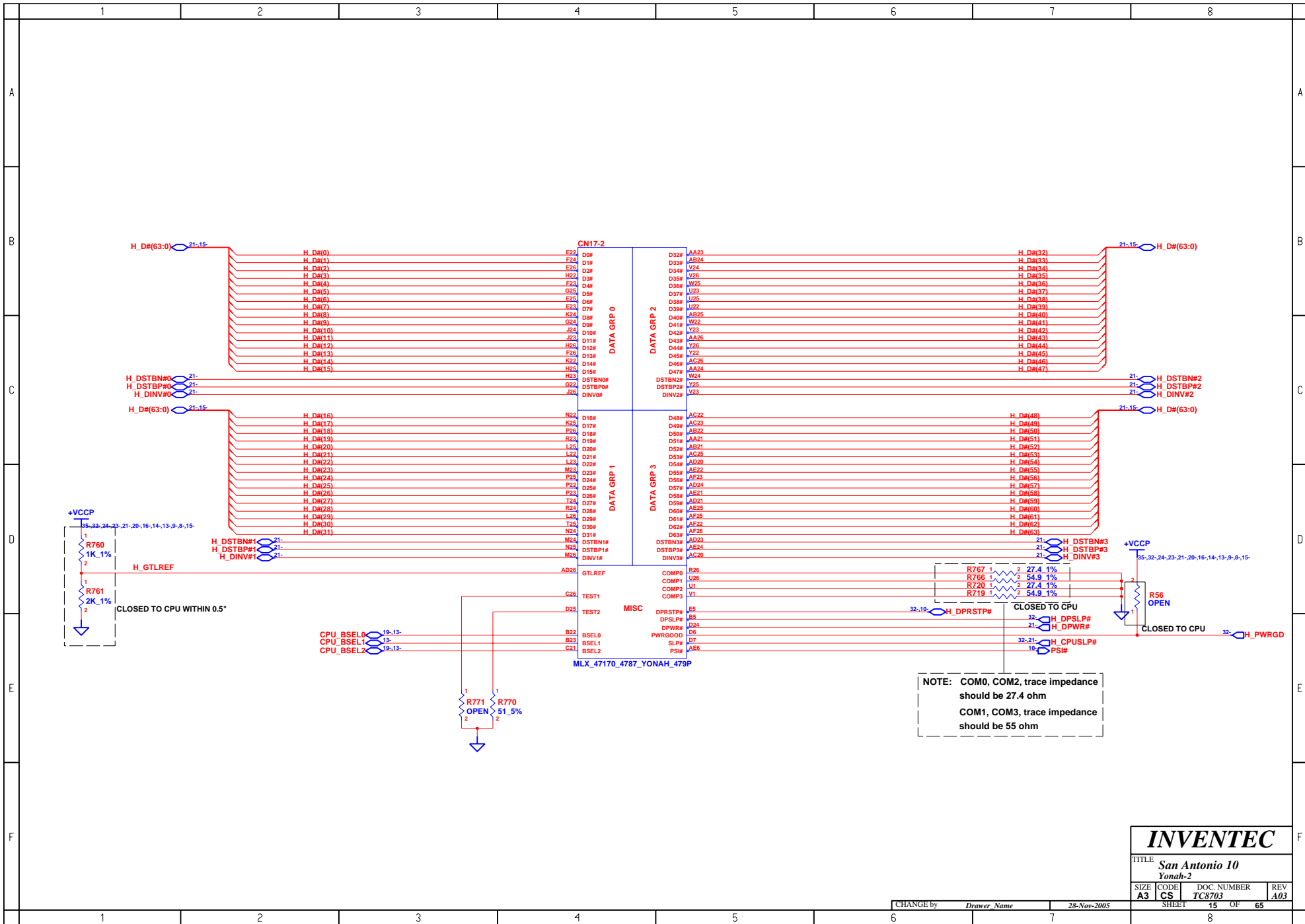

# INVENTEC

TITLE: San Antonio 10  
Yonah-2

SIZE	CODE	DOC. NUMBER	REV
A3	CS	TC8703	A03

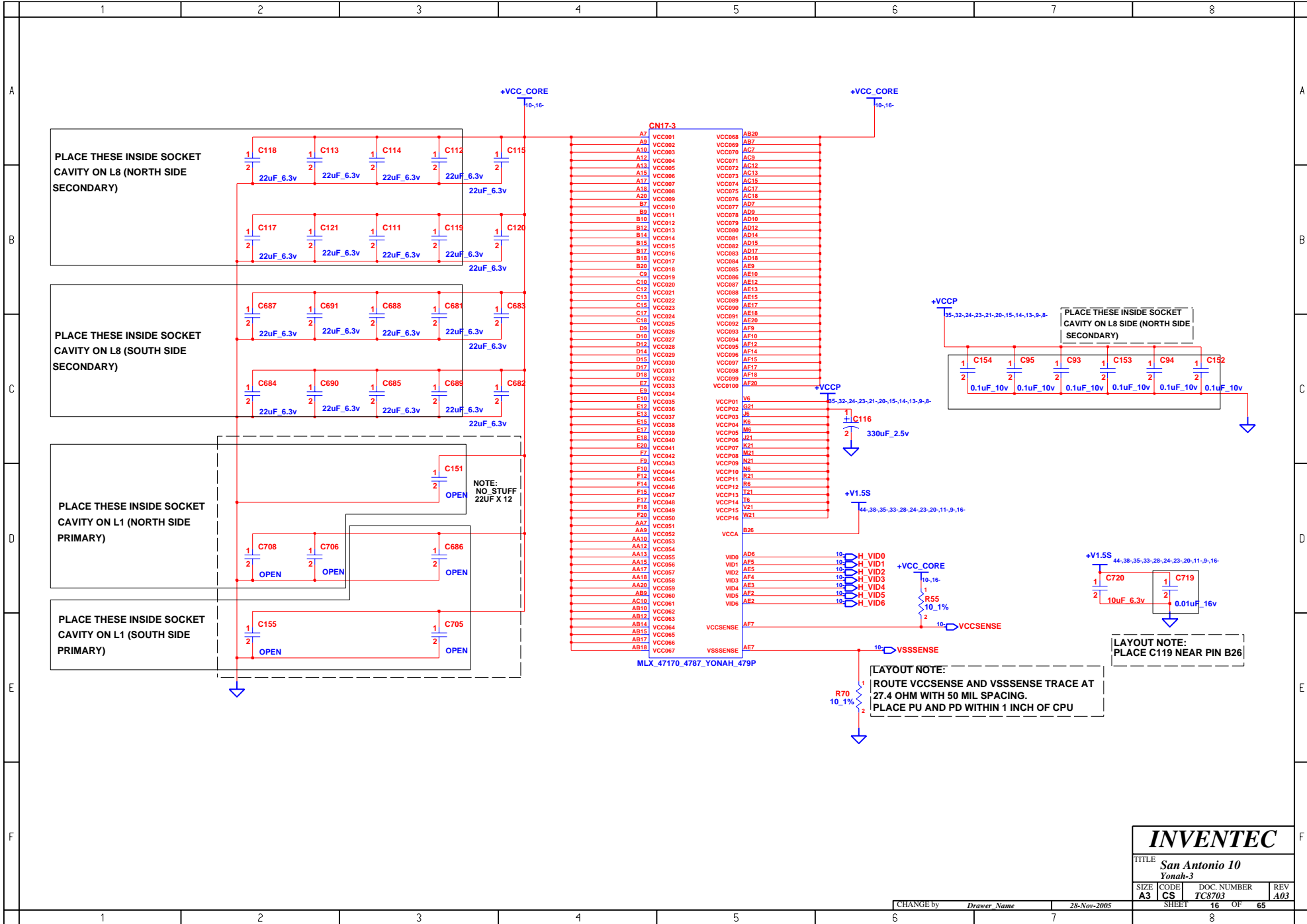

<b>INVENTEC</b>			
TITLE <b>San Antonio 10 Yonah-3</b>			
SIZE <b>A3</b>	CODE <b>CS</b>	DOC. NUMBER <b>TC8703</b>	REV <b>A03</b>
CHANGE by <i>Drawer Name</i>		28-Nov-2005	SHEET 16 OF 65



	1	2	3	4	5	6	7	8																																																																																																																																																																																																																																																					
A	<p style="text-align: center;"><b>CN17-4</b></p> <table border="0" style="width: 100%; border-collapse: collapse;"> <tr><td style="width: 50%; text-align: center;">A4</td><td style="width: 50%; text-align: center;">VSS001</td><td style="width: 50%; text-align: center;">P8</td></tr> <tr><td style="text-align: center;">A5</td><td style="text-align: center;">VSS002</td><td style="text-align: center;">P21</td></tr> <tr><td style="text-align: center;">A11</td><td style="text-align: center;">VSS003</td><td style="text-align: center;">VSS004</td></tr> <tr><td style="text-align: center;">A14</td><td style="text-align: center;">VSS004</td><td style="text-align: center;">VSS005</td></tr> <tr><td style="text-align: center;">A15</td><td style="text-align: center;">VSS005</td><td style="text-align: center;">VSS006</td></tr> <tr><td style="text-align: center;">A16</td><td style="text-align: center;">VSS006</td><td style="text-align: center;">VSS007</td></tr> <tr><td style="text-align: center;">A23</td><td style="text-align: center;">VSS007</td><td style="text-align: center;">VSS008</td></tr> <tr><td style="text-align: center;">A26</td><td style="text-align: center;">VSS008</td><td style="text-align: center;">VSS009</td></tr> <tr><td style="text-align: center;">B8</td><td style="text-align: center;">VSS009</td><td style="text-align: center;">VSS010</td></tr> <tr><td style="text-align: center;">B9</td><td style="text-align: center;">VSS010</td><td style="text-align: center;">VSS011</td></tr> <tr><td style="text-align: center;">B11</td><td style="text-align: center;">VSS011</td><td style="text-align: center;">VSS012</td></tr> <tr><td style="text-align: center;">B12</td><td style="text-align: center;">VSS012</td><td style="text-align: center;">VSS013</td></tr> <tr><td style="text-align: center;">B13</td><td style="text-align: center;">VSS013</td><td style="text-align: center;">VSS014</td></tr> <tr><td style="text-align: center;">B15</td><td style="text-align: center;">VSS014</td><td style="text-align: center;">VSS015</td></tr> <tr><td style="text-align: center;">B21</td><td style="text-align: center;">VSS015</td><td style="text-align: center;">VSS016</td></tr> <tr><td style="text-align: center;">B24</td><td style="text-align: center;">VSS016</td><td style="text-align: center;">VSS017</td></tr> <tr><td style="text-align: center;">C3</td><td style="text-align: center;">VSS017</td><td style="text-align: center;">VSS018</td></tr> <tr><td style="text-align: center;">C8</td><td style="text-align: center;">VSS018</td><td style="text-align: center;">VSS019</td></tr> <tr><td style="text-align: center;">C11</td><td style="text-align: center;">VSS019</td><td style="text-align: center;">VSS020</td></tr> <tr><td style="text-align: center;">C14</td><td style="text-align: center;">VSS020</td><td style="text-align: center;">VSS021</td></tr> <tr><td style="text-align: center;">C18</td><td style="text-align: center;">VSS021</td><td style="text-align: center;">VSS022</td></tr> <tr><td style="text-align: center;">C19</td><td style="text-align: center;">VSS022</td><td style="text-align: center;">VSS023</td></tr> <tr><td style="text-align: center;">C2</td><td style="text-align: center;">VSS023</td><td style="text-align: center;">VSS024</td></tr> <tr><td style="text-align: center;">C23</td><td style="text-align: center;">VSS024</td><td style="text-align: center;">VSS025</td></tr> <tr><td style="text-align: center;">C25</td><td style="text-align: center;">VSS025</td><td style="text-align: center;">VSS026</td></tr> <tr><td style="text-align: center;">D1</td><td style="text-align: center;">VSS026</td><td style="text-align: center;">VSS027</td></tr> <tr><td style="text-align: center;">D4</td><td style="text-align: center;">VSS027</td><td style="text-align: center;">VSS028</td></tr> <tr><td style="text-align: center;">D8</td><td style="text-align: center;">VSS028</td><td style="text-align: center;">VSS029</td></tr> <tr><td style="text-align: center;">D11</td><td style="text-align: center;">VSS029</td><td style="text-align: center;">VSS030</td></tr> <tr><td style="text-align: center;">D13</td><td style="text-align: center;">VSS030</td><td style="text-align: center;">VSS031</td></tr> <tr><td style="text-align: center;">D16</td><td style="text-align: center;">VSS031</td><td style="text-align: center;">VSS032</td></tr> <tr><td style="text-align: center;">D19</td><td style="text-align: center;">VSS032</td><td style="text-align: center;">VSS033</td></tr> <tr><td style="text-align: center;">D23</td><td style="text-align: center;">VSS033</td><td style="text-align: center;">VSS034</td></tr> <tr><td style="text-align: center;">D26</td><td style="text-align: center;">VSS034</td><td style="text-align: center;">VSS035</td></tr> <tr><td style="text-align: center;">E3</td><td style="text-align: center;">VSS035</td><td style="text-align: center;">VSS036</td></tr> <tr><td style="text-align: center;">E5</td><td style="text-align: center;">VSS036</td><td style="text-align: center;">VSS037</td></tr> <tr><td style="text-align: center;">E6</td><td style="text-align: center;">VSS037</td><td style="text-align: center;">VSS038</td></tr> <tr><td style="text-align: center;">E11</td><td style="text-align: center;">VSS038</td><td style="text-align: center;">VSS039</td></tr> <tr><td style="text-align: center;">E14</td><td style="text-align: center;">VSS039</td><td style="text-align: center;">VSS040</td></tr> <tr><td style="text-align: center;">E16</td><td style="text-align: center;">VSS040</td><td style="text-align: center;">VSS041</td></tr> <tr><td style="text-align: center;">E18</td><td style="text-align: center;">VSS041</td><td style="text-align: center;">VSS042</td></tr> <tr><td style="text-align: center;">E21</td><td style="text-align: center;">VSS042</td><td style="text-align: center;">VSS043</td></tr> <tr><td style="text-align: center;">E24</td><td style="text-align: center;">VSS043</td><td style="text-align: center;">VSS044</td></tr> <tr><td style="text-align: center;">F3</td><td style="text-align: center;">VSS044</td><td style="text-align: center;">VSS045</td></tr> <tr><td style="text-align: center;">F8</td><td style="text-align: center;">VSS045</td><td style="text-align: center;">VSS046</td></tr> <tr><td style="text-align: center;">F11</td><td style="text-align: center;">VSS046</td><td style="text-align: center;">VSS047</td></tr> <tr><td style="text-align: center;">F15</td><td style="text-align: center;">VSS047</td><td style="text-align: center;">VSS048</td></tr> <tr><td style="text-align: center;">F16</td><td style="text-align: center;">VSS048</td><td style="text-align: center;">VSS049</td></tr> <tr><td style="text-align: center;">F19</td><td style="text-align: center;">VSS049</td><td style="text-align: center;">VSS050</td></tr> <tr><td style="text-align: center;">F2</td><td style="text-align: center;">VSS050</td><td style="text-align: center;">VSS051</td></tr> <tr><td style="text-align: center;">F23</td><td style="text-align: center;">VSS051</td><td style="text-align: center;">VSS052</td></tr> <tr><td style="text-align: center;">F25</td><td style="text-align: center;">VSS052</td><td style="text-align: center;">VSS053</td></tr> <tr><td style="text-align: center;">G4</td><td style="text-align: center;">VSS053</td><td style="text-align: center;">VSS054</td></tr> <tr><td style="text-align: center;">G1</td><td style="text-align: center;">VSS054</td><td style="text-align: center;">VSS055</td></tr> <tr><td style="text-align: center;">G23</td><td style="text-align: center;">VSS055</td><td style="text-align: center;">VSS056</td></tr> <tr><td style="text-align: center;">G26</td><td style="text-align: center;">VSS056</td><td style="text-align: center;">VSS057</td></tr> <tr><td style="text-align: center;">H3</td><td style="text-align: center;">VSS057</td><td style="text-align: center;">VSS058</td></tr> <tr><td style="text-align: center;">H6</td><td style="text-align: center;">VSS058</td><td style="text-align: center;">VSS059</td></tr> <tr><td style="text-align: center;">H21</td><td style="text-align: center;">VSS059</td><td style="text-align: center;">VSS060</td></tr> <tr><td style="text-align: center;">H24</td><td style="text-align: center;">VSS060</td><td style="text-align: center;">VSS061</td></tr> <tr><td style="text-align: center;">J2</td><td style="text-align: center;">VSS061</td><td style="text-align: center;">VSS062</td></tr> <tr><td style="text-align: center;">J5</td><td style="text-align: center;">VSS062</td><td style="text-align: center;">VSS063</td></tr> <tr><td style="text-align: center;">J23</td><td style="text-align: center;">VSS063</td><td style="text-align: center;">VSS064</td></tr> <tr><td style="text-align: center;">J25</td><td style="text-align: center;">VSS064</td><td style="text-align: center;">VSS065</td></tr> <tr><td style="text-align: center;">K1</td><td style="text-align: center;">VSS065</td><td style="text-align: center;">VSS066</td></tr> <tr><td style="text-align: center;">K4</td><td style="text-align: center;">VSS066</td><td style="text-align: center;">VSS067</td></tr> <tr><td style="text-align: center;">K23</td><td style="text-align: center;">VSS067</td><td style="text-align: center;">VSS068</td></tr> <tr><td style="text-align: center;">K26</td><td style="text-align: center;">VSS068</td><td style="text-align: center;">VSS069</td></tr> <tr><td style="text-align: center;">L3</td><td style="text-align: center;">VSS069</td><td style="text-align: center;">VSS070</td></tr> <tr><td style="text-align: center;">L4</td><td style="text-align: center;">VSS070</td><td style="text-align: center;">VSS071</td></tr> <tr><td style="text-align: center;">L21</td><td style="text-align: center;">VSS071</td><td style="text-align: center;">VSS072</td></tr> <tr><td style="text-align: center;">L24</td><td style="text-align: center;">VSS072</td><td style="text-align: center;">VSS073</td></tr> <tr><td style="text-align: center;">M2</td><td style="text-align: center;">VSS073</td><td style="text-align: center;">VSS074</td></tr> <tr><td style="text-align: center;">M5</td><td style="text-align: center;">VSS074</td><td style="text-align: center;">VSS075</td></tr> <tr><td style="text-align: center;">M23</td><td style="text-align: center;">VSS075</td><td style="text-align: center;">VSS076</td></tr> <tr><td style="text-align: center;">M25</td><td style="text-align: center;">VSS076</td><td style="text-align: center;">VSS077</td></tr> <tr><td style="text-align: center;">N1</td><td style="text-align: center;">VSS077</td><td style="text-align: center;">VSS078</td></tr> <tr><td style="text-align: center;">N6</td><td style="text-align: center;">VSS078</td><td style="text-align: center;">VSS079</td></tr> <tr><td style="text-align: center;">N23</td><td style="text-align: center;">VSS079</td><td style="text-align: center;">VSS080</td></tr> <tr><td style="text-align: center;">N26</td><td style="text-align: center;">VSS080</td><td style="text-align: center;">VSS081</td></tr> <tr><td style="text-align: center;">P3</td><td style="text-align: center;">VSS081</td><td style="text-align: center;">VSS082</td></tr> </table> <p style="text-align: center;"><b>MLX_47170_4787_YONAH_479P</b></p>									A4	VSS001	P8	A5	VSS002	P21	A11	VSS003	VSS004	A14	VSS004	VSS005	A15	VSS005	VSS006	A16	VSS006	VSS007	A23	VSS007	VSS008	A26	VSS008	VSS009	B8	VSS009	VSS010	B9	VSS010	VSS011	B11	VSS011	VSS012	B12	VSS012	VSS013	B13	VSS013	VSS014	B15	VSS014	VSS015	B21	VSS015	VSS016	B24	VSS016	VSS017	C3	VSS017	VSS018	C8	VSS018	VSS019	C11	VSS019	VSS020	C14	VSS020	VSS021	C18	VSS021	VSS022	C19	VSS022	VSS023	C2	VSS023	VSS024	C23	VSS024	VSS025	C25	VSS025	VSS026	D1	VSS026	VSS027	D4	VSS027	VSS028	D8	VSS028	VSS029	D11	VSS029	VSS030	D13	VSS030	VSS031	D16	VSS031	VSS032	D19	VSS032	VSS033	D23	VSS033	VSS034	D26	VSS034	VSS035	E3	VSS035	VSS036	E5	VSS036	VSS037	E6	VSS037	VSS038	E11	VSS038	VSS039	E14	VSS039	VSS040	E16	VSS040	VSS041	E18	VSS041	VSS042	E21	VSS042	VSS043	E24	VSS043	VSS044	F3	VSS044	VSS045	F8	VSS045	VSS046	F11	VSS046	VSS047	F15	VSS047	VSS048	F16	VSS048	VSS049	F19	VSS049	VSS050	F2	VSS050	VSS051	F23	VSS051	VSS052	F25	VSS052	VSS053	G4	VSS053	VSS054	G1	VSS054	VSS055	G23	VSS055	VSS056	G26	VSS056	VSS057	H3	VSS057	VSS058	H6	VSS058	VSS059	H21	VSS059	VSS060	H24	VSS060	VSS061	J2	VSS061	VSS062	J5	VSS062	VSS063	J23	VSS063	VSS064	J25	VSS064	VSS065	K1	VSS065	VSS066	K4	VSS066	VSS067	K23	VSS067	VSS068	K26	VSS068	VSS069	L3	VSS069	VSS070	L4	VSS070	VSS071	L21	VSS071	VSS072	L24	VSS072	VSS073	M2	VSS073	VSS074	M5	VSS074	VSS075	M23	VSS075	VSS076	M25	VSS076	VSS077	N1	VSS077	VSS078	N6	VSS078	VSS079	N23	VSS079	VSS080	N26	VSS080	VSS081	P3	VSS081	VSS082	
A4										VSS001	P8																																																																																																																																																																																																																																																		
A5										VSS002	P21																																																																																																																																																																																																																																																		
A11										VSS003	VSS004																																																																																																																																																																																																																																																		
A14										VSS004	VSS005																																																																																																																																																																																																																																																		
A15										VSS005	VSS006																																																																																																																																																																																																																																																		
A16										VSS006	VSS007																																																																																																																																																																																																																																																		
A23										VSS007	VSS008																																																																																																																																																																																																																																																		
A26										VSS008	VSS009																																																																																																																																																																																																																																																		
B8										VSS009	VSS010																																																																																																																																																																																																																																																		
B9										VSS010	VSS011																																																																																																																																																																																																																																																		
B11										VSS011	VSS012																																																																																																																																																																																																																																																		
B12										VSS012	VSS013																																																																																																																																																																																																																																																		
B13										VSS013	VSS014																																																																																																																																																																																																																																																		
B15										VSS014	VSS015																																																																																																																																																																																																																																																		
B21										VSS015	VSS016																																																																																																																																																																																																																																																		
B24										VSS016	VSS017																																																																																																																																																																																																																																																		
C3	VSS017	VSS018																																																																																																																																																																																																																																																											
C8	VSS018	VSS019																																																																																																																																																																																																																																																											
C11	VSS019	VSS020																																																																																																																																																																																																																																																											
C14	VSS020	VSS021																																																																																																																																																																																																																																																											
C18	VSS021	VSS022																																																																																																																																																																																																																																																											
C19	VSS022	VSS023																																																																																																																																																																																																																																																											
C2	VSS023	VSS024																																																																																																																																																																																																																																																											
C23	VSS024	VSS025																																																																																																																																																																																																																																																											
C25	VSS025	VSS026																																																																																																																																																																																																																																																											
D1	VSS026	VSS027																																																																																																																																																																																																																																																											
D4	VSS027	VSS028																																																																																																																																																																																																																																																											
D8	VSS028	VSS029																																																																																																																																																																																																																																																											
D11	VSS029	VSS030																																																																																																																																																																																																																																																											
D13	VSS030	VSS031																																																																																																																																																																																																																																																											
D16	VSS031	VSS032																																																																																																																																																																																																																																																											
D19	VSS032	VSS033																																																																																																																																																																																																																																																											
D23	VSS033	VSS034																																																																																																																																																																																																																																																											
D26	VSS034	VSS035																																																																																																																																																																																																																																																											
E3	VSS035	VSS036																																																																																																																																																																																																																																																											
E5	VSS036	VSS037																																																																																																																																																																																																																																																											
E6	VSS037	VSS038																																																																																																																																																																																																																																																											
E11	VSS038	VSS039																																																																																																																																																																																																																																																											
E14	VSS039	VSS040																																																																																																																																																																																																																																																											
E16	VSS040	VSS041																																																																																																																																																																																																																																																											
E18	VSS041	VSS042																																																																																																																																																																																																																																																											
E21	VSS042	VSS043																																																																																																																																																																																																																																																											
E24	VSS043	VSS044																																																																																																																																																																																																																																																											
F3	VSS044	VSS045																																																																																																																																																																																																																																																											
F8	VSS045	VSS046																																																																																																																																																																																																																																																											
F11	VSS046	VSS047																																																																																																																																																																																																																																																											
F15	VSS047	VSS048																																																																																																																																																																																																																																																											
F16	VSS048	VSS049																																																																																																																																																																																																																																																											
F19	VSS049	VSS050																																																																																																																																																																																																																																																											
F2	VSS050	VSS051																																																																																																																																																																																																																																																											
F23	VSS051	VSS052																																																																																																																																																																																																																																																											
F25	VSS052	VSS053																																																																																																																																																																																																																																																											
G4	VSS053	VSS054																																																																																																																																																																																																																																																											
G1	VSS054	VSS055																																																																																																																																																																																																																																																											
G23	VSS055	VSS056																																																																																																																																																																																																																																																											
G26	VSS056	VSS057																																																																																																																																																																																																																																																											
H3	VSS057	VSS058																																																																																																																																																																																																																																																											
H6	VSS058	VSS059																																																																																																																																																																																																																																																											
H21	VSS059	VSS060																																																																																																																																																																																																																																																											
H24	VSS060	VSS061																																																																																																																																																																																																																																																											
J2	VSS061	VSS062																																																																																																																																																																																																																																																											
J5	VSS062	VSS063																																																																																																																																																																																																																																																											
J23	VSS063	VSS064																																																																																																																																																																																																																																																											
J25	VSS064	VSS065																																																																																																																																																																																																																																																											
K1	VSS065	VSS066																																																																																																																																																																																																																																																											
K4	VSS066	VSS067																																																																																																																																																																																																																																																											
K23	VSS067	VSS068																																																																																																																																																																																																																																																											
K26	VSS068	VSS069																																																																																																																																																																																																																																																											
L3	VSS069	VSS070																																																																																																																																																																																																																																																											
L4	VSS070	VSS071																																																																																																																																																																																																																																																											
L21	VSS071	VSS072																																																																																																																																																																																																																																																											
L24	VSS072	VSS073																																																																																																																																																																																																																																																											
M2	VSS073	VSS074																																																																																																																																																																																																																																																											
M5	VSS074	VSS075																																																																																																																																																																																																																																																											
M23	VSS075	VSS076																																																																																																																																																																																																																																																											
M25	VSS076	VSS077																																																																																																																																																																																																																																																											
N1	VSS077	VSS078																																																																																																																																																																																																																																																											
N6	VSS078	VSS079																																																																																																																																																																																																																																																											
N23	VSS079	VSS080																																																																																																																																																																																																																																																											
N26	VSS080	VSS081																																																																																																																																																																																																																																																											
P3	VSS081	VSS082																																																																																																																																																																																																																																																											
B																																																																																																																																																																																																																																																													
C																																																																																																																																																																																																																																																													
D																																																																																																																																																																																																																																																													
E																																																																																																																																																																																																																																																													
F																																																																																																																																																																																																																																																													

<b>INVENTEC</b>			
TITLE <i>San Antonio 10</i>			
<i>Yonah-4</i>			
SIZE <b>A3</b>	CODE <b>CS</b>	DOC. NUMBER <b>TC8703</b>	REV <b>A03</b>
CHANGE by <i>Drawer Name</i>		28-Nov-2005	
SHEET 17		OF 65	

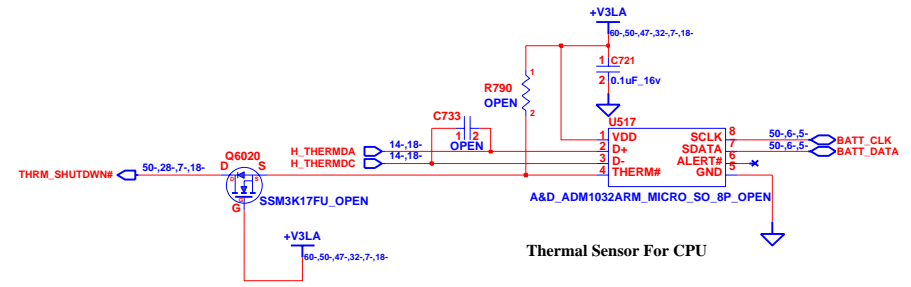
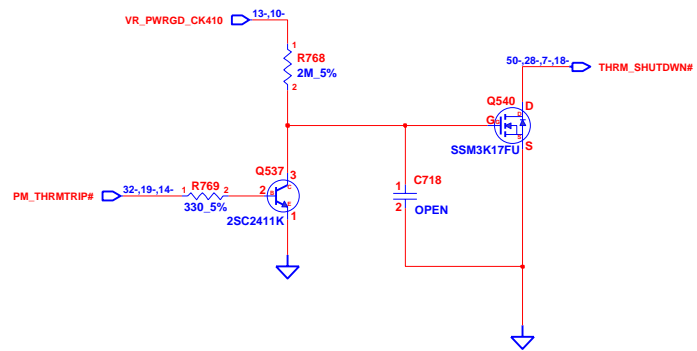
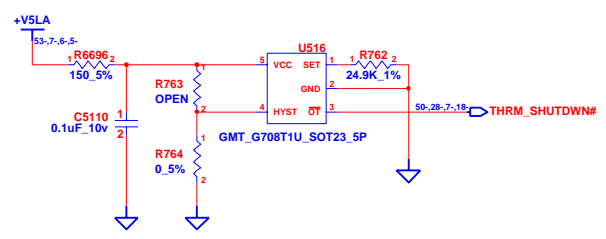
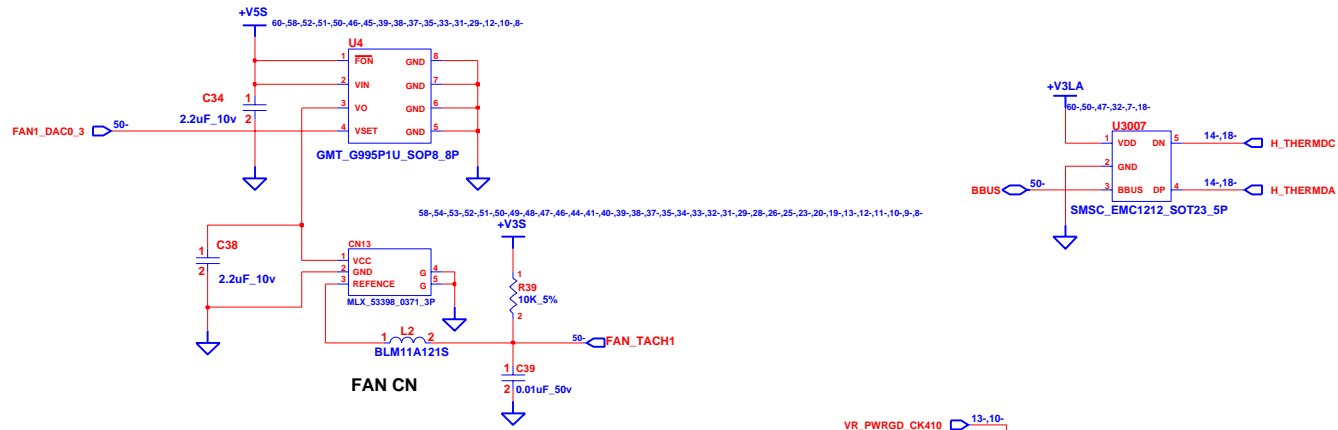

<b>INVENTEC</b>			
TITLE <b>San Antonio 10</b>			
<b>THERMAL&amp;FAN CONTROLLER</b>			
SIZE	CODE	DOC. NUMBER	REV
A3	CS	TC8703	A03

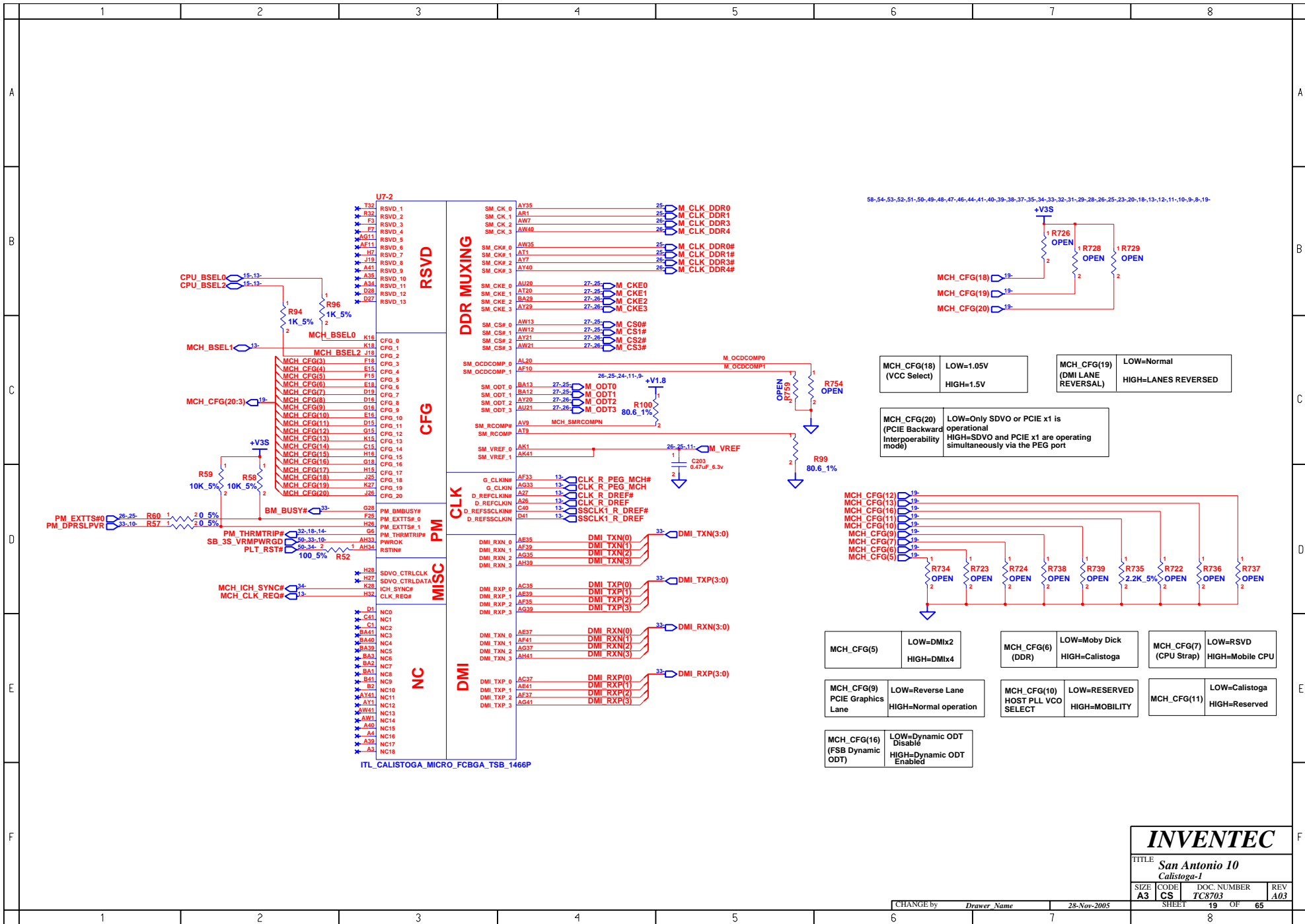

58-54-53-52-51-50-49-48-47-46-44-41-40-39-38-37-35-34-33-32-31-29-28-26-25-23-20-18-15-12-11-10-9-8-19

MCH_CFG(18) (VCC Select)	LOW=1.05V HIGH=1.5V	MCH_CFG(19) (DMI LANE REVERSAL)	LOW=Normal HIGH=LANES REVERSED
-----------------------------	------------------------	------------------------------------	-----------------------------------

MCH\_CFG(20)  
(PCIe Backward Interoperability mode)

LOW=Only SDVO or PCIe x1 is operational  
HIGH=SDVO and PCIe x1 are operating simultaneously via the PEG port

MCH_CFG(5)	LOW=DMiX2 HIGH=DMiX4	MCH_CFG(6) (DDR)	LOW=Moby Dick HIGH=Calistoga	MCH_CFG(7) (CPU Strap)	LOW=RSVD HIGH=Mobile CPU
MCH_CFG(9) PCIe Graphics Lane	LOW=Reverse Lane HIGH=Normal operation	MCH_CFG(10) HOST PLL VCO SELECT	LOW=RESERVED HIGH=MOBILITY	MCH_CFG(11)	LOW=Calistoga HIGH=Reserved
MCH_CFG(16) (FSB Dynamic ODT)	LOW=Dynamic ODT Disable HIGH=Dynamic ODT Enabled				

# INVENTEC

TITLE: **San Antonio 10 Calistoga-1**

SIZE	CODE	DOC. NUMBER	REV
A3	CS	TC8703	A03

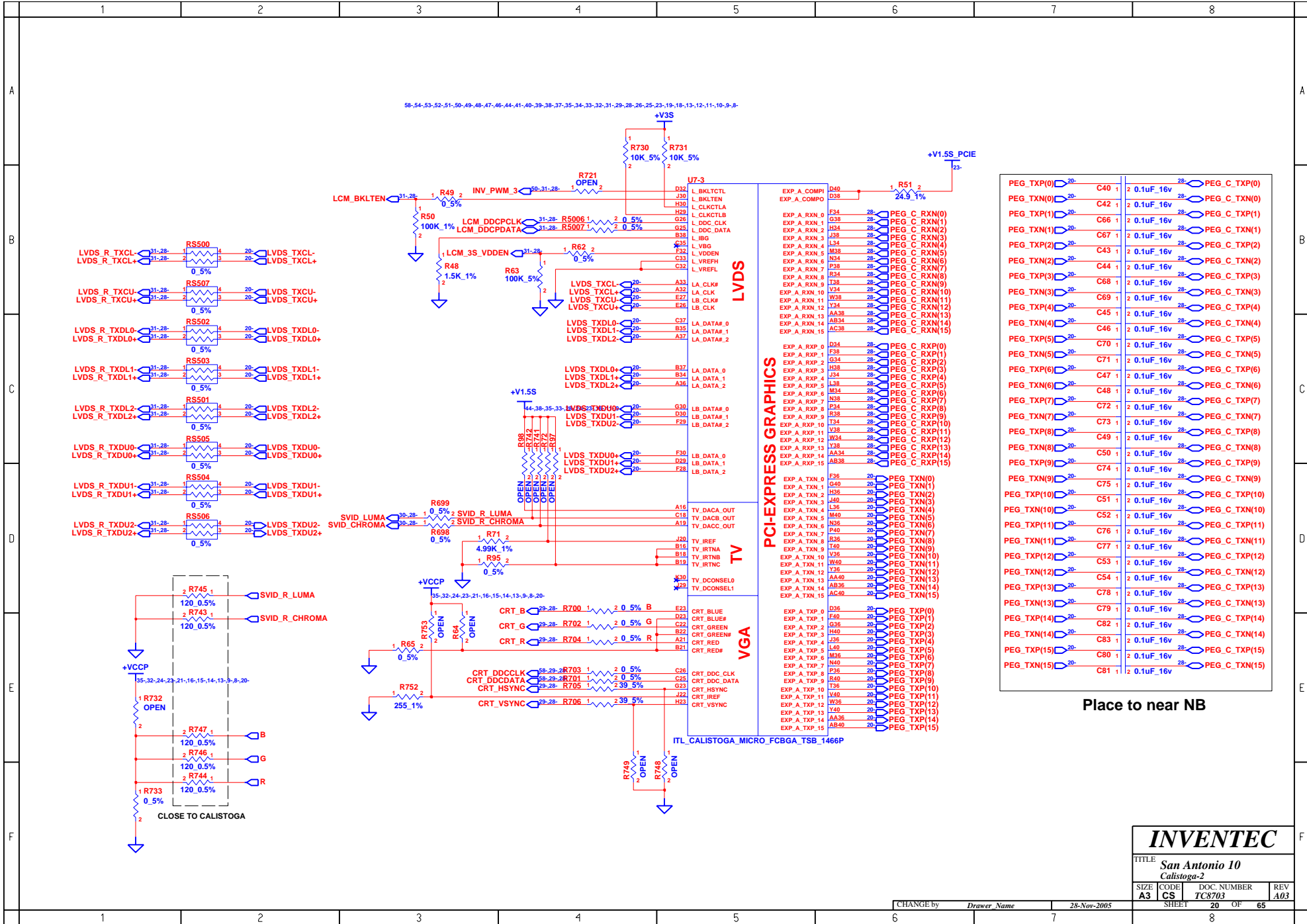

**INVENTEC**

TITLE			
San Antonio 10			
Calistoga-2			
SIZE	CODE	DOC. NUMBER	REV
A3	CS	TC8703	A03
SHEET		20	OF 65

CHANGE by *Drawer Name* 28-Nov-2005

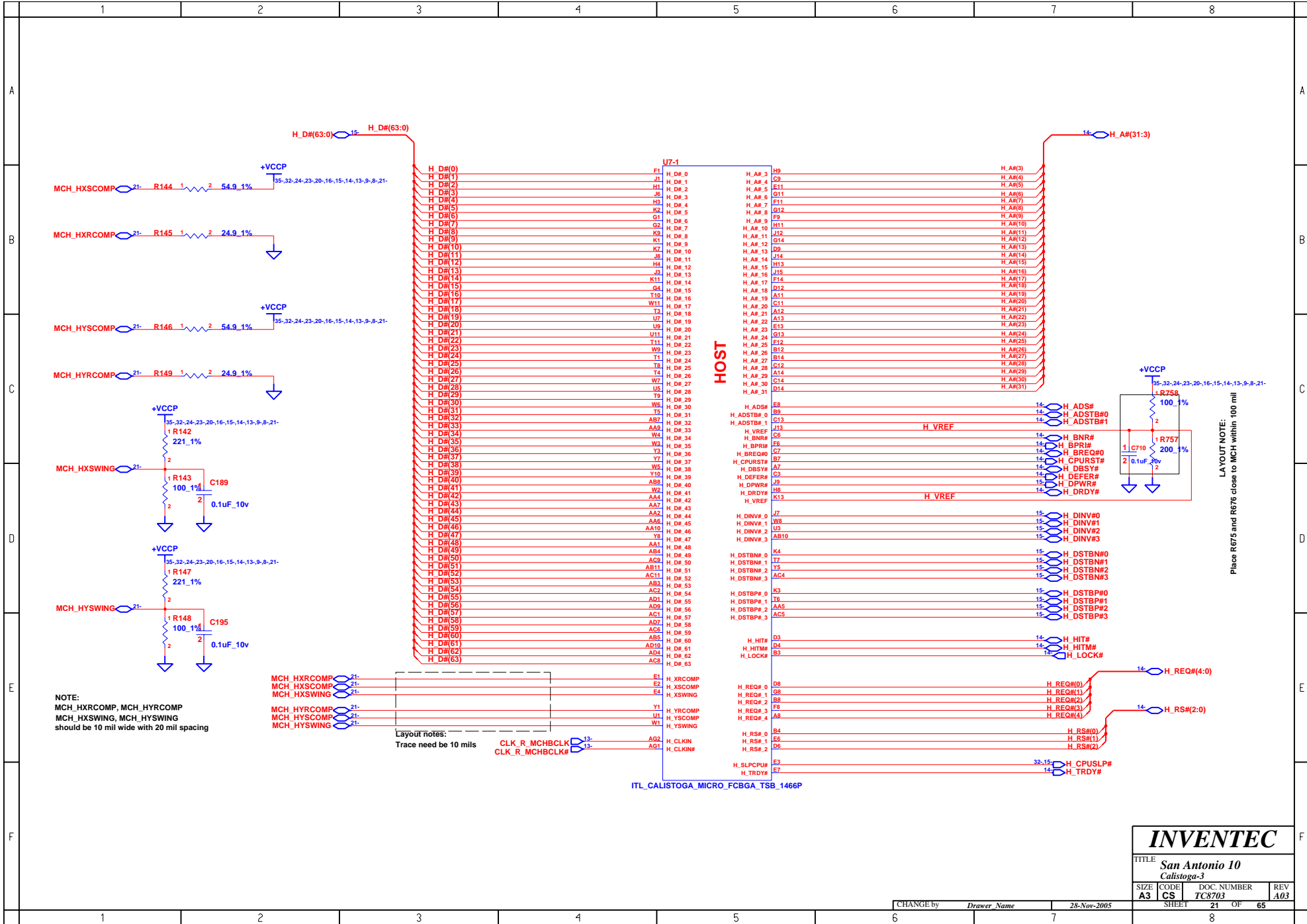

LAYOUT NOTE:  
Place R675 and R676 close to MCH within 100 mil

# INVENTEC

TITLE: **San Antonio 10**  
**Calistoga-3**

SIZE	CODE	DOC. NUMBER	REV
A3	CS	TC8703	A03

CHANGE by *Drawer Name* 28-Nov-2005

SHEET 21 OF 65

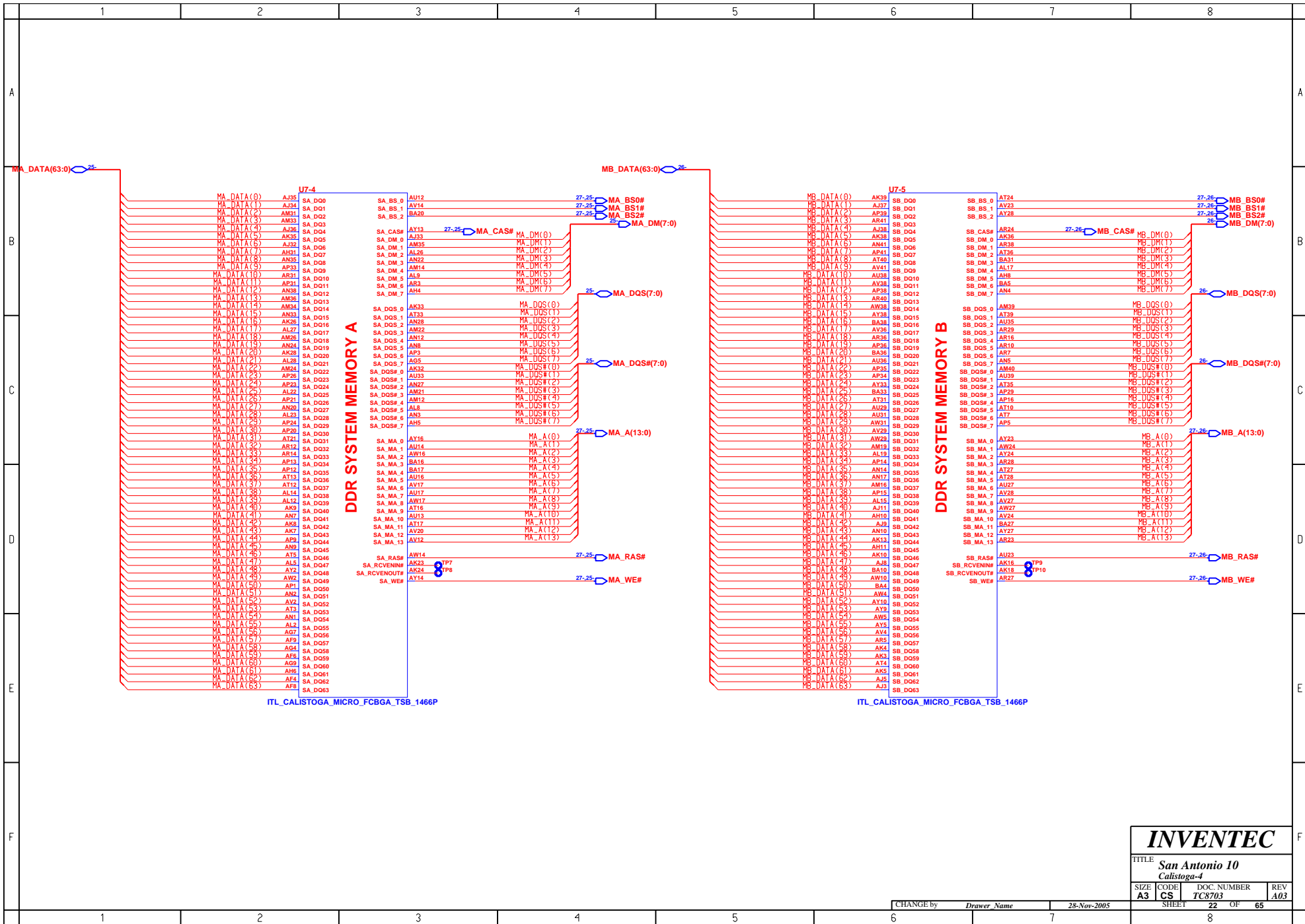

**INVENTEC**

TITLE: **San Antonio 10**  
*Calistoga-4*

SIZE	CODE	DOC. NUMBER	REV
A3	CS	TC8703	A03

CHANGE by: *Drawer Name* 28-Nov-2005 SHEET 22 OF 65



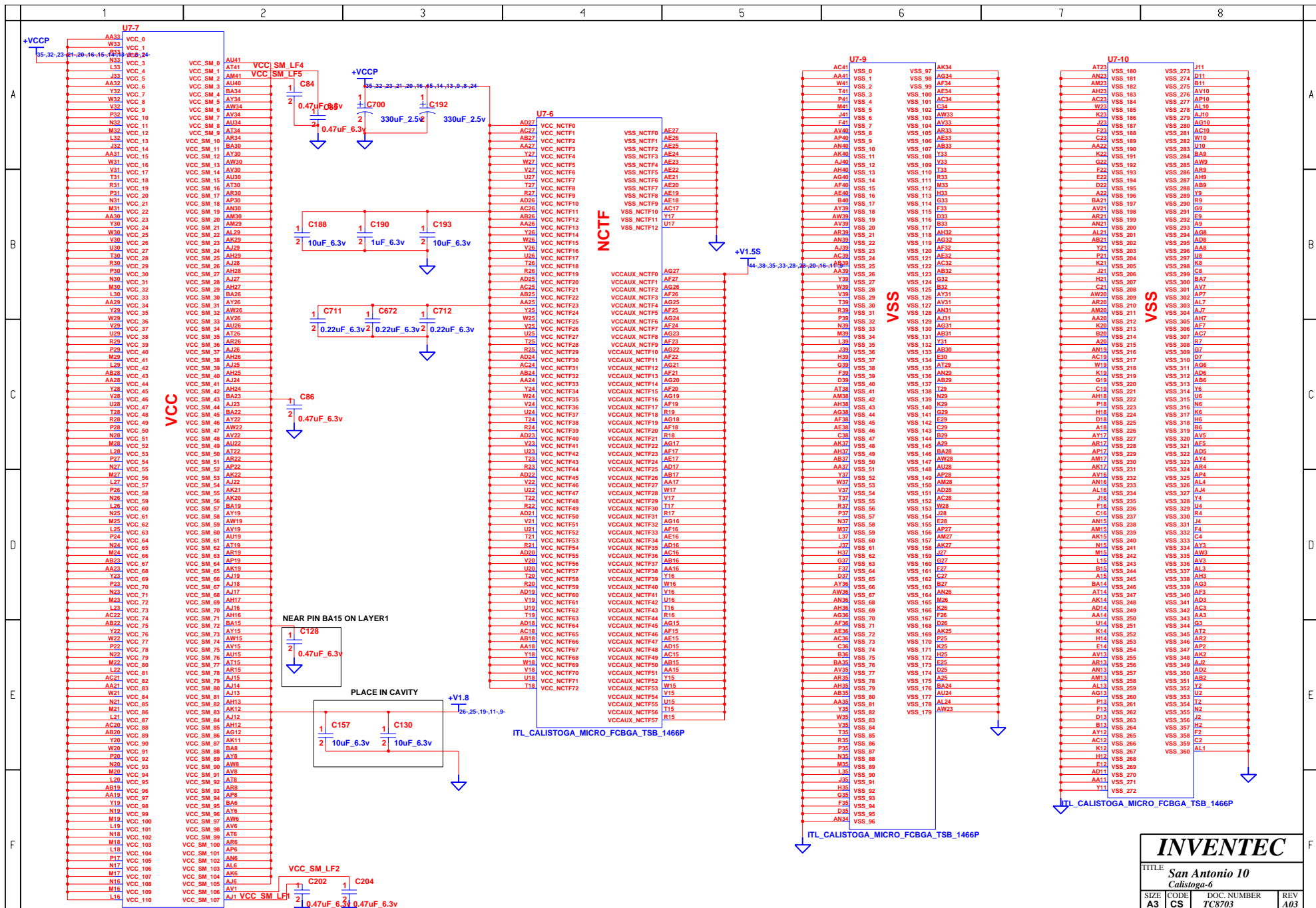

**INVENTEC**

TITLE  
San Antonio 10  
Calistoga-6

SIZE A3	CODE CS	DOC. NUMBER TC8703	REV A03
------------	------------	-----------------------	------------

SHEET 24 OF 65



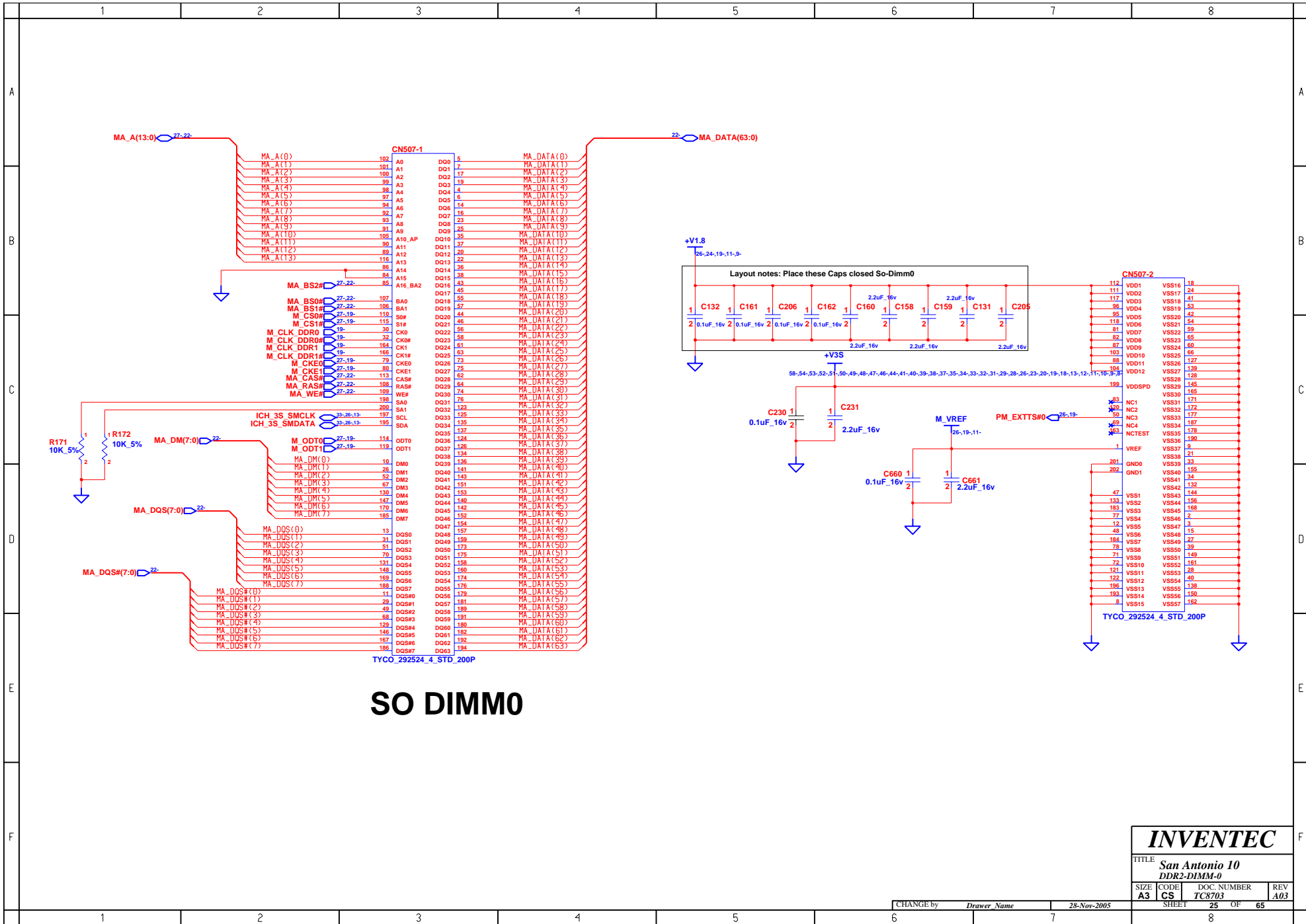

# SO DIMMO

<b>INVENTEC</b>			
TITLE <b>San Antonio 10 DDR2-DIMM-0</b>			
SIZE <b>A3</b>	CODE <b>CS</b>	DOC NUMBER <b>TC8703</b>	REV <b>A03</b>
CHANGE by <i>Drawer Name</i>		28-Nov-2005	SHEET 25 OF 65

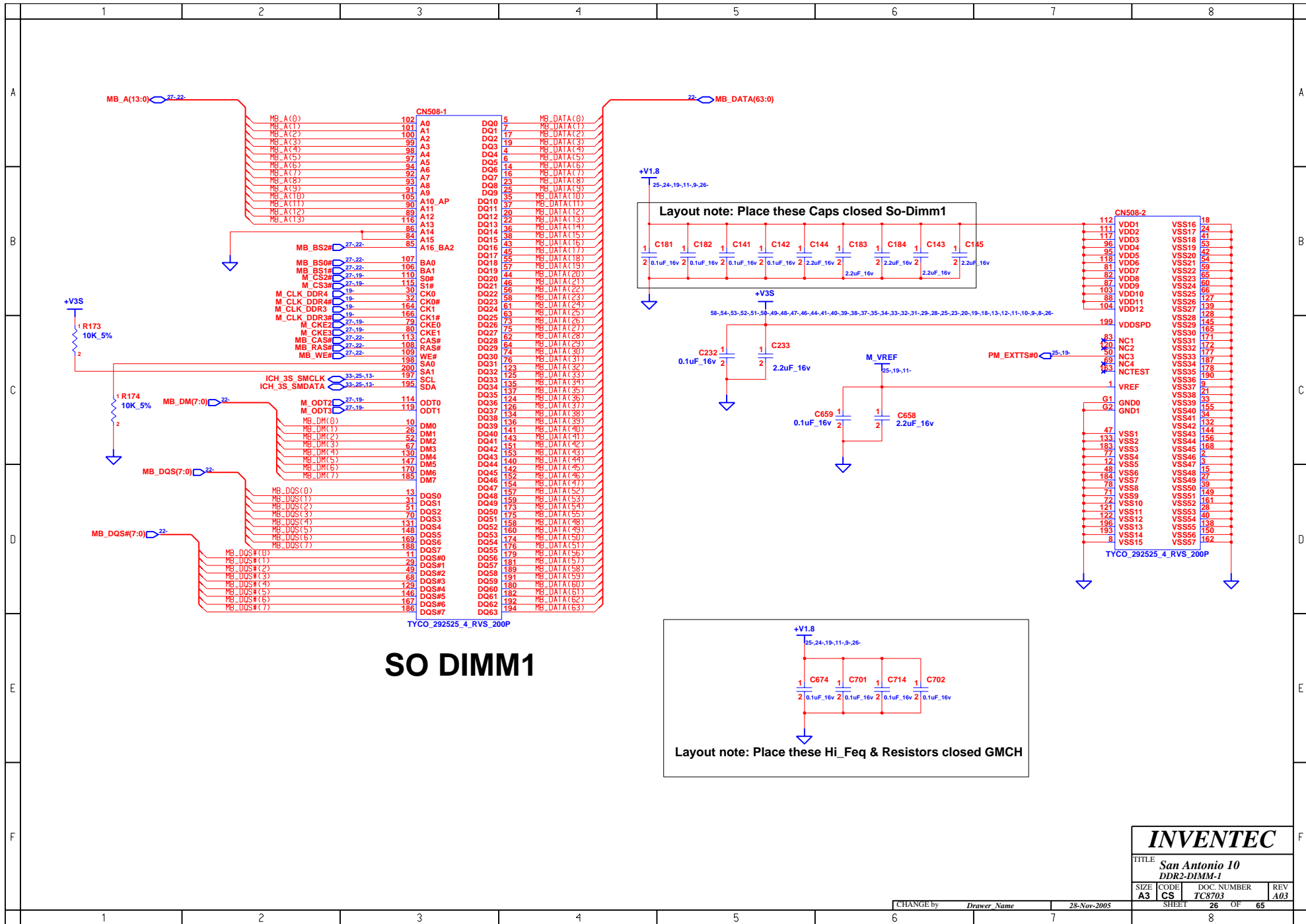

# SO DIMM1

## INVENTEC

TITLE: San Antonio 10			
DDR2-DIMM-1			
SIZE: A3	CODE: CS	DOC NUMBER: TC8703	REV: A03

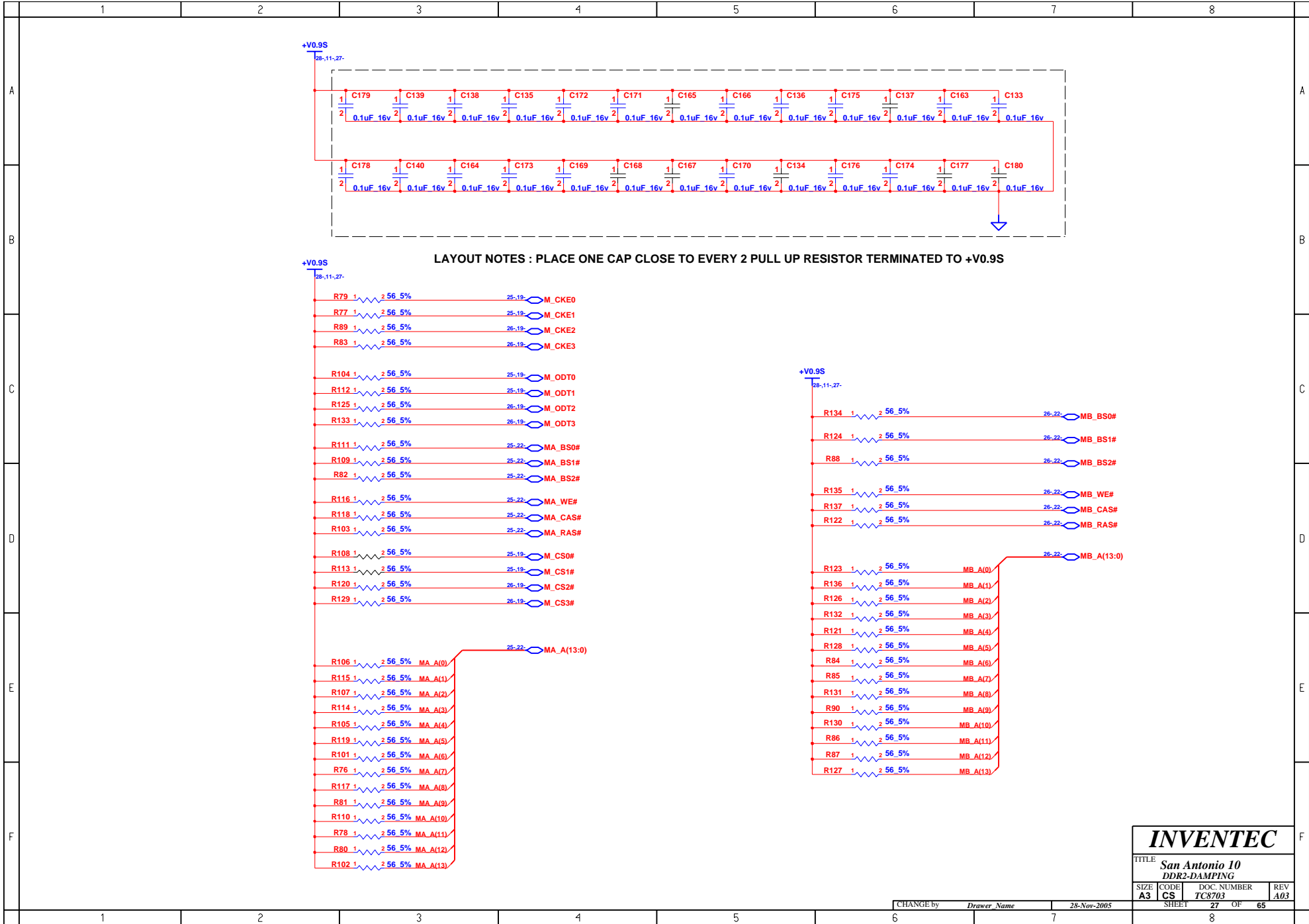

<b>INVENTEC</b>			
TITLE: <b>San Antonio 10</b>			
DDR2-DAMPING			
SIZE	CODE	DOC. NUMBER	REV
A3	CS	TC8703	A03
CHANGE by		Drawer Name	28-Nov-2005
SHEET		27	OF 65

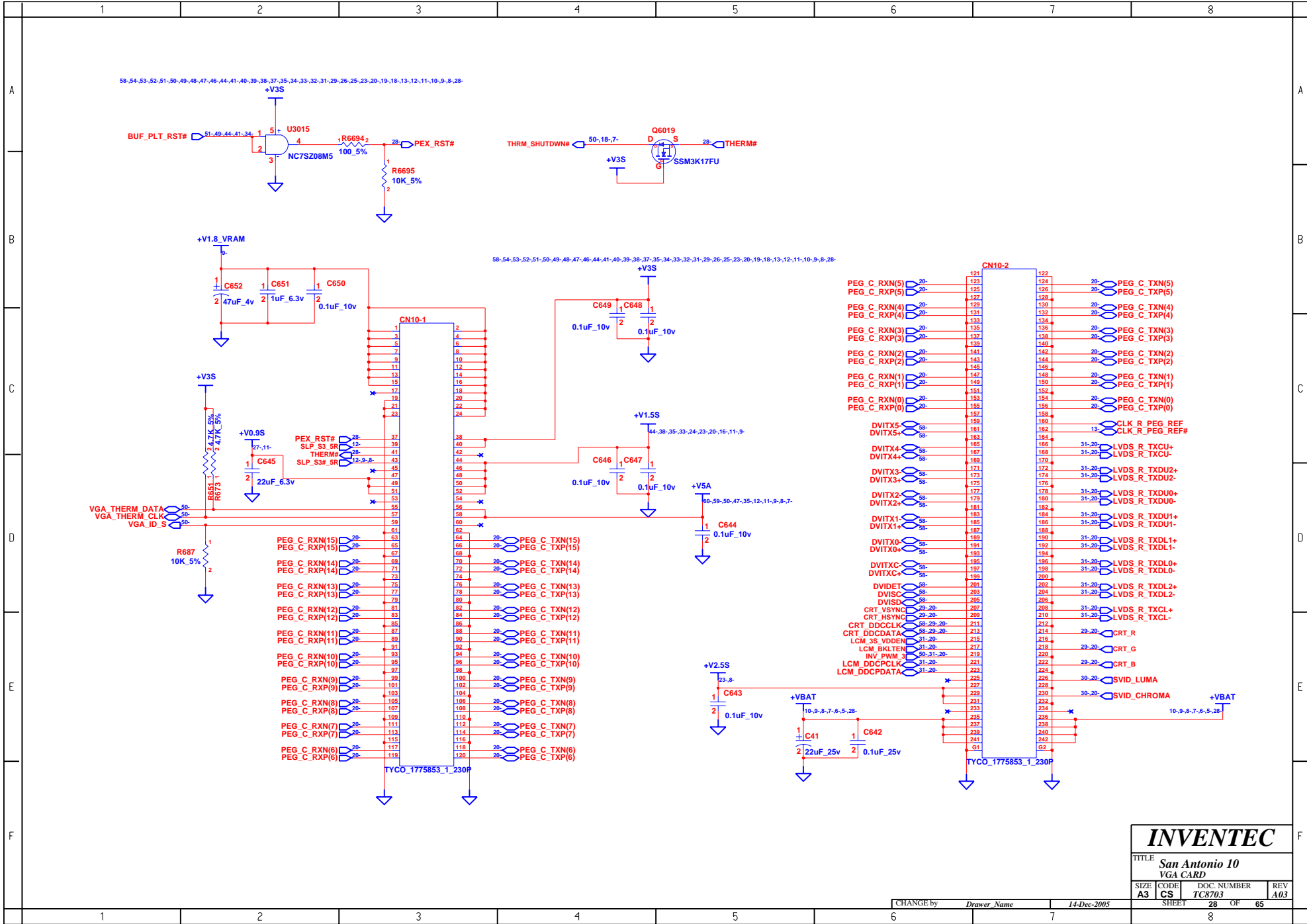

# INVENTEC

TITLE: **San Antonio 10  
VGA CARD**

SIZE	CODE	DOC. NUMBER	REV
A3	CS	TC8703	A03
SHEET 28		OF 65	

CHANGE by *Drawer Name* 14-Dec-2005

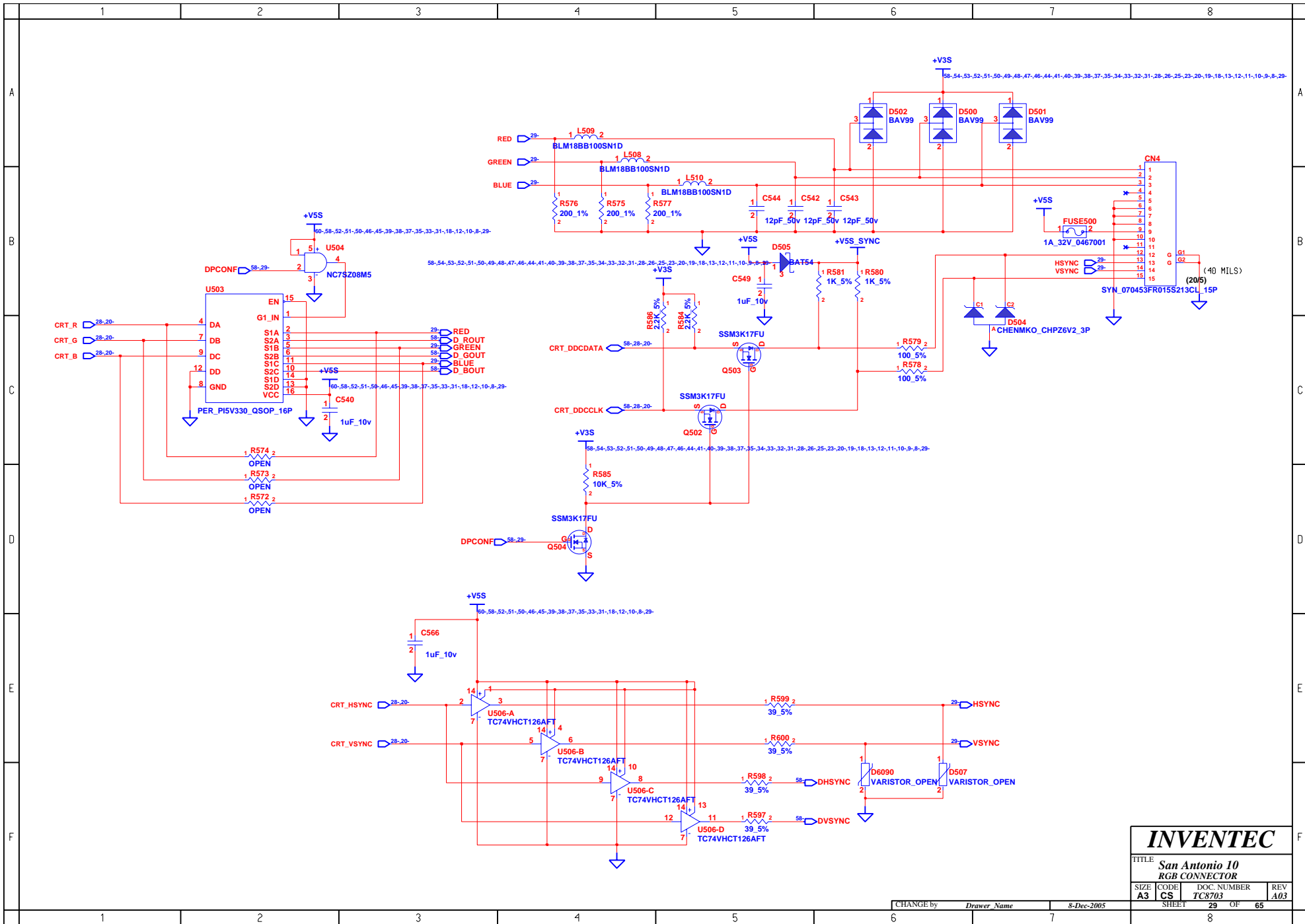

<b>INVENTEC</b>			
TITLE <b>San Antonio 10 RGB CONNECTOR</b>			
SIZE <b>A3</b>	CODE <b>CS</b>	DOC. NUMBER <b>TC8703</b>	REV <b>A03</b>
CHANGE by <i>Drawer Name</i>		8-Dec-2005	
SHEET <b>29</b>		OF <b>65</b>	

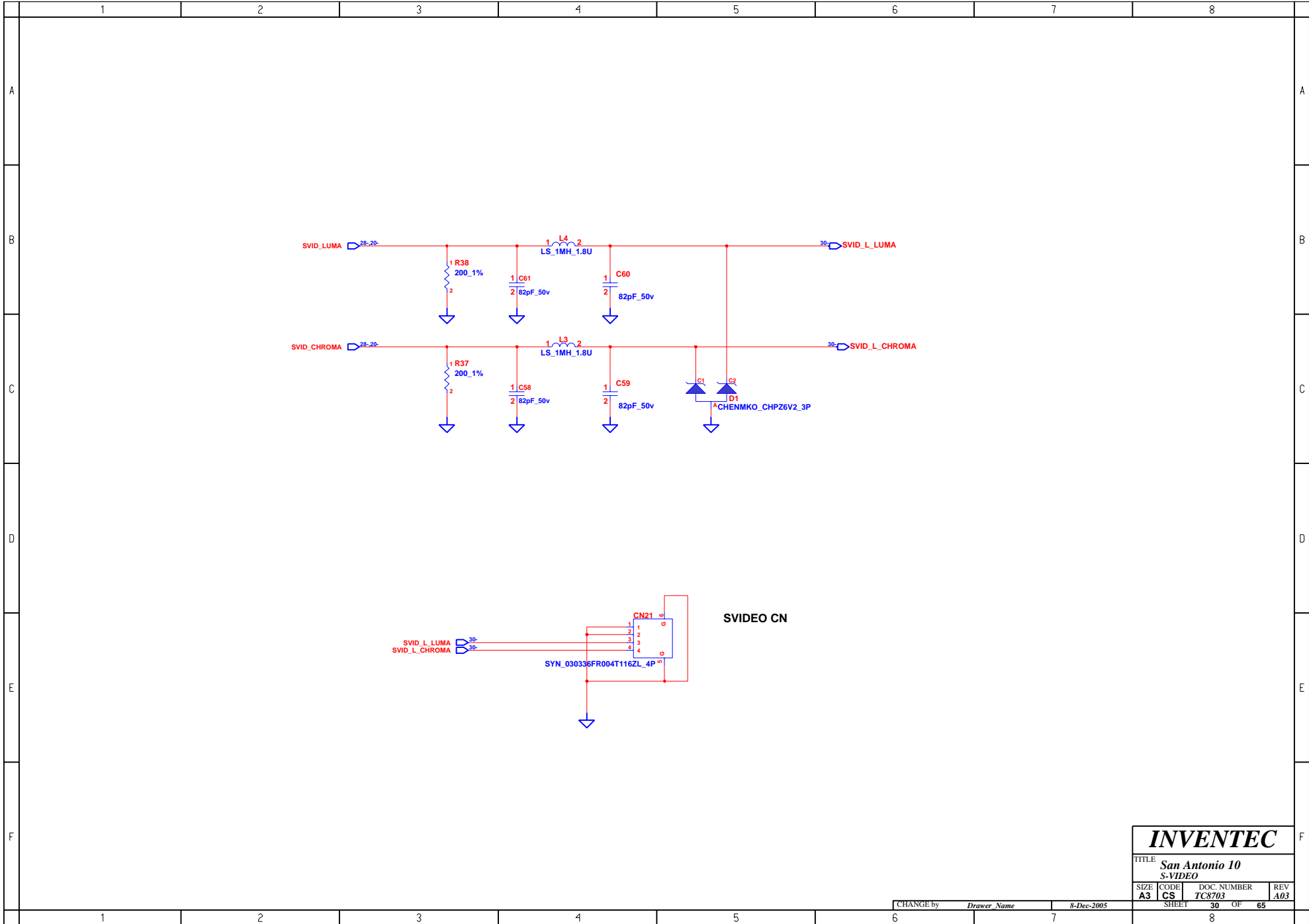

**INVENTEC**

TITLE *San Antonio 10  
S-VIDEO*

SIZE <b>A3</b>	CODE <b>CS</b>	DOC. NUMBER <i>TC8703</i>	REV <b>A03</b>
-------------------	-------------------	------------------------------	-------------------

CHANGE by *Drawer Name* 8-Dec-2005

SHEET 30 OF 65

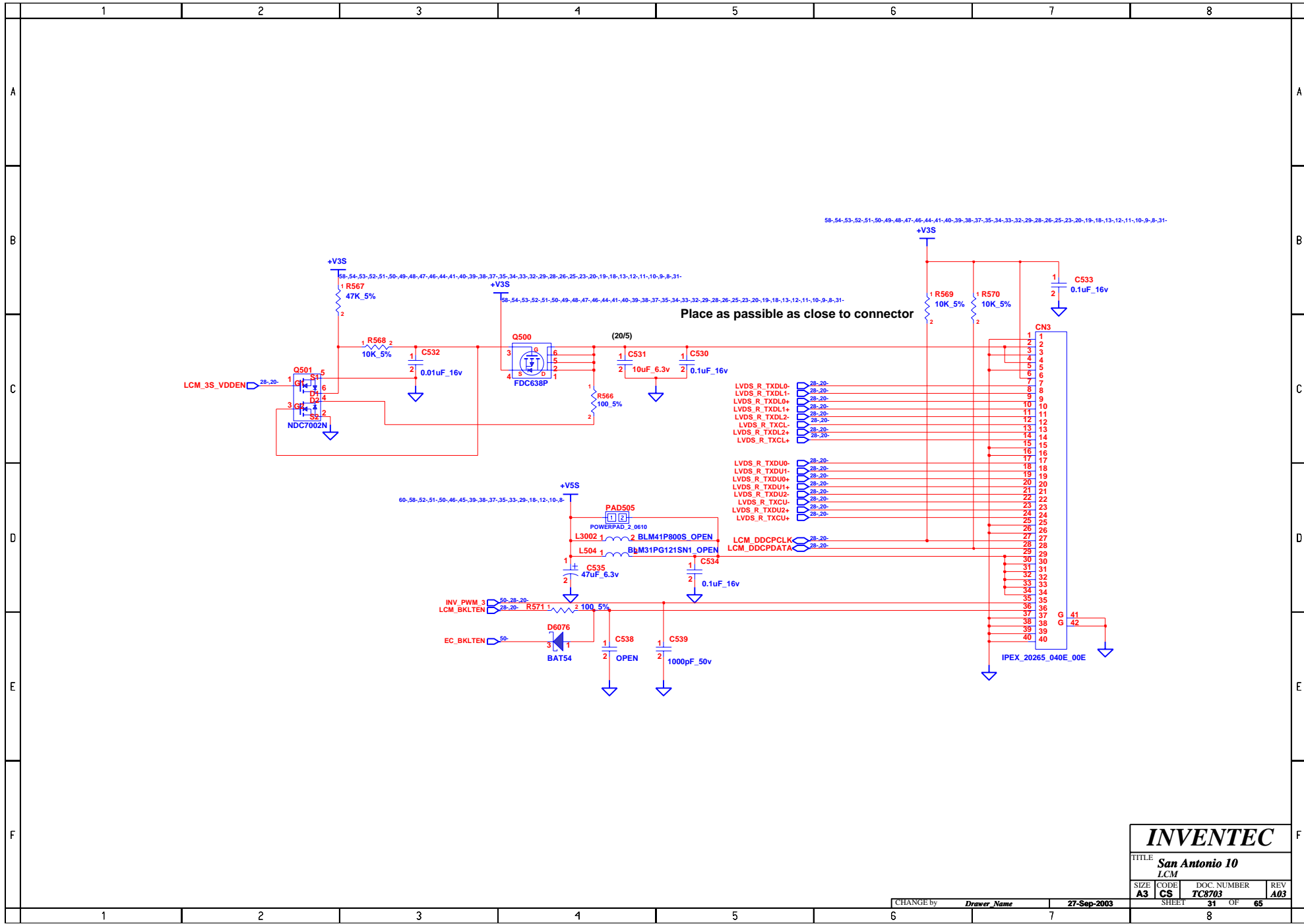

<b>INVENTEC</b>			
TITLE <b>San Antonio 10</b>			
LCM			
SIZE <b>A3</b>	CODE <b>CS</b>	DOC. NUMBER <b>TC8703</b>	REV <b>A03</b>

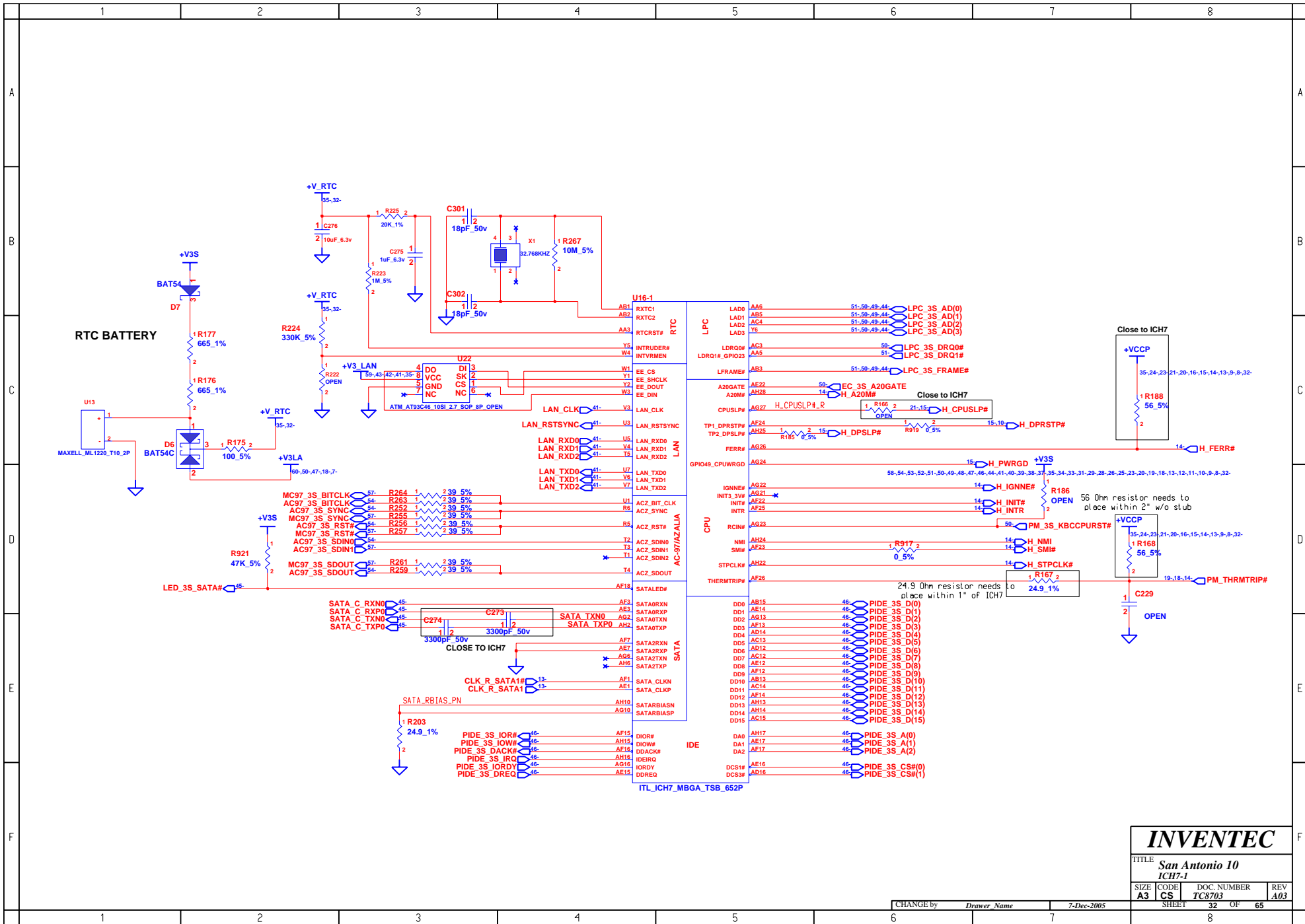

<b>INVENTEC</b>			
TITLE: San Antonio 10 ICH7-1			
SIZE: A3	CODE: CS	DOC. NUMBER: TC8703	REV: A03
CHANGE by: Drawer Name		7-Dec-2005	
SHEET: 32		OF: 65	



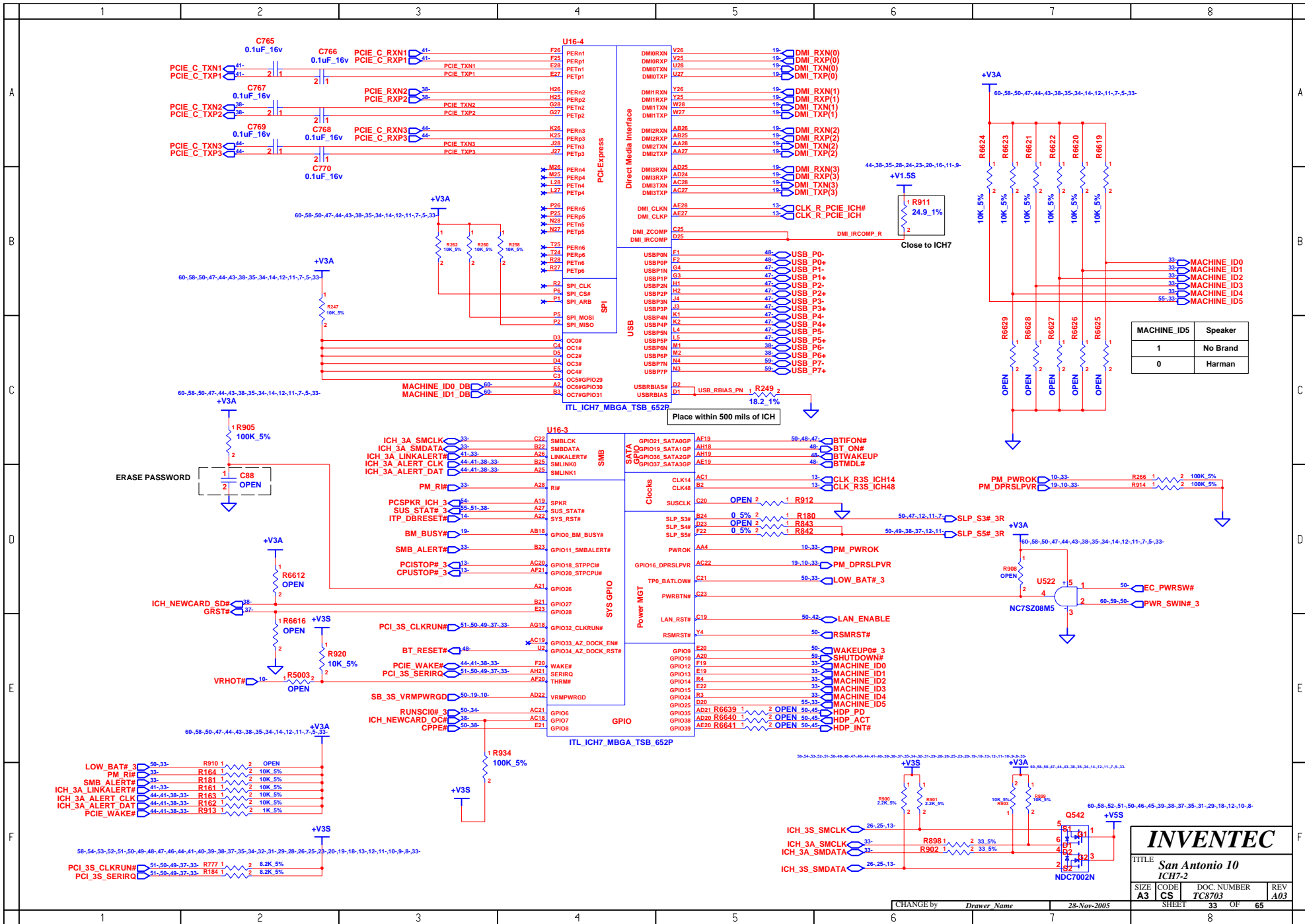

MACHINE_ID5	Speaker
1	No Brand
0	Harman

**INVENTEC**

TITLE: San Antonio 10 ICH-2

SIZE A3	CODE CS	DOC NUMBER TC8703	REV A03
SHEET 33		OF 65	

CHANGE by *Drawer Name* 28-Nov-2005

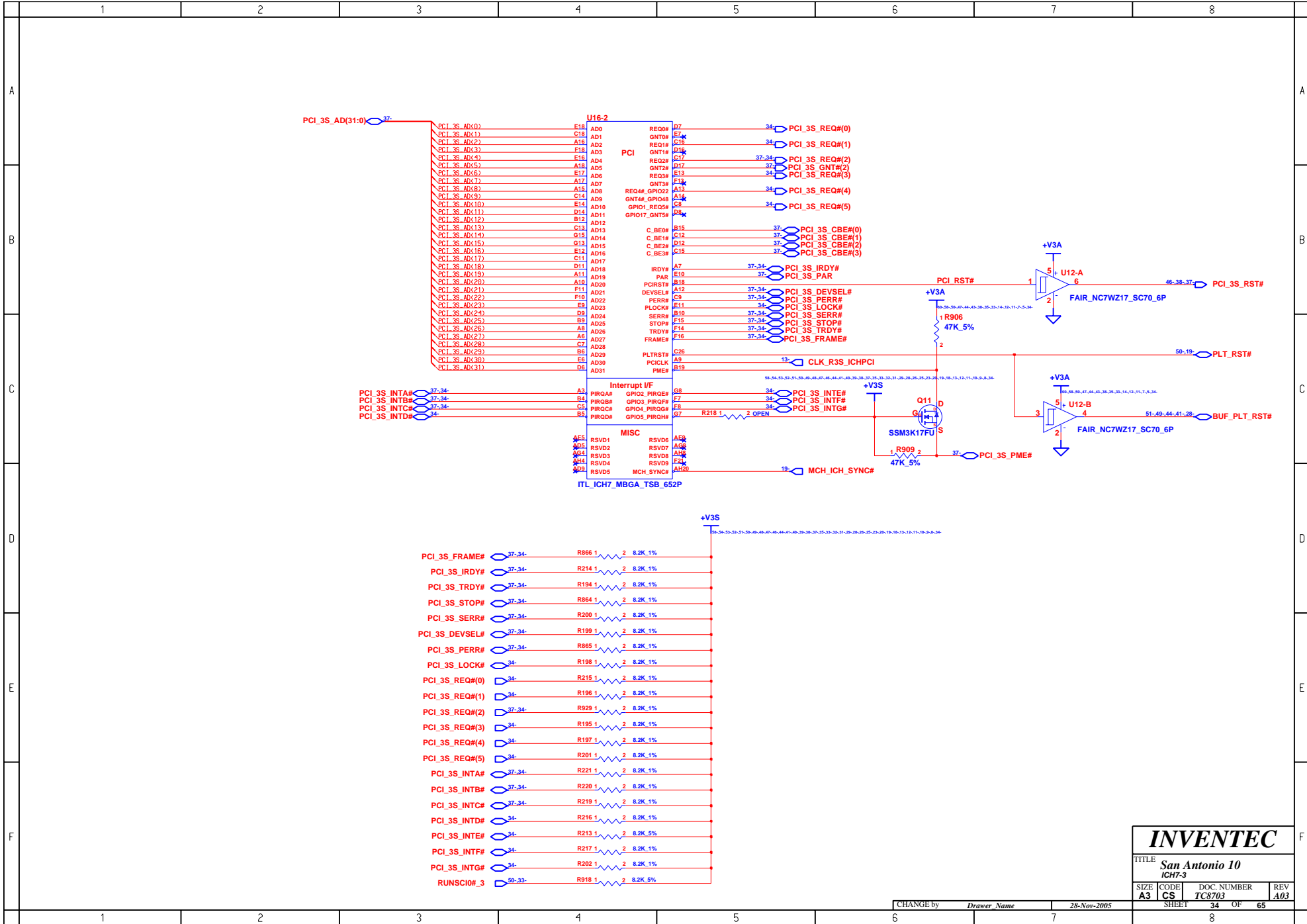

<b>INVENTEC</b>			
TITLE <b>San Antonio 10</b>			
IC17-3			
SIZE <b>A3</b>	CODE <b>CS</b>	DOC. NUMBER <b>TC8703</b>	REV <b>A03</b>
CHANGE by <i>Drawer Name</i>		28-Nov-2005	SHEET <b>34</b> OF <b>65</b>



	1	2	3	4	5	6	7	8
A								
B								
C								
D								
E								
F								

U16-5

A4	VSS1	VSS96	P28
A23	VSS2	VSS99	R1
B1	VSS3	VSS100	R11
B8	VSS4	VSS101	R12
B11	VSS5	VSS102	R13
B14	VSS6	VSS103	R14
B17	VSS7	VSS104	R15
B20	VSS8	VSS105	R16
B26	VSS9	VSS106	R17
B28	VSS10	VSS107	R18
C2	VSS11	VSS108	T6
C6	VSS12	VSS109	T12
C27	VSS13	VSS110	T13
D10	VSS14	VSS111	T14
D13	VSS15	VSS112	T15
D18	VSS16	VSS113	T16
D21	VSS17	VSS114	T17
D24	VSS18	VSS115	U1
E1	VSS19	VSS116	U12
E2	VSS20	VSS117	U13
E4	VSS21	VSS118	U14
E8	VSS22	VSS119	U15
E15	VSS23	VSS120	U16
F3	VSS24	VSS121	U17
F4	VSS25	VSS122	U24
F4	VSS26	VSS123	U25
F12	VSS27	VSS124	U26
F27	VSS28	VSS125	V2
F28	VSS29	VSS126	V13
G1	VSS30	VSS127	V15
G2	VSS31	VSS128	V24
G5	VSS32	VSS129	V27
G6	VSS33	VSS130	W6
G9	VSS34	VSS131	W24
G14	VSS35	VSS132	W25
G18	VSS36	VSS133	W26
G21	VSS37	VSS134	Y2
G24	VSS38	VSS135	Y24
G25	VSS39	VSS136	Y27
G26	VSS40	VSS137	Y28
H3	VSS41	VSS138	AA1
H4	VSS42	VSS139	AA24
H5	VSS43	VSS140	AA25
H24	VSS44	VSS141	AA26
H27	VSS45	VSS142	AB6
H28	VSS46	VSS143	AB11
J1	VSS47	VSS144	AB14
J2	VSS48	VSS145	AB16
J5	VSS49	VSS146	AB19
J24	VSS50	VSS147	AB21
J25	VSS51	VSS148	AB22
J26	VSS52	VSS149	AB27
K24	VSS53	VSS150	AB28
K27	VSS54	VSS151	AC2
K28	VSS55	VSS152	AC5
L13	VSS56	VSS153	AC9
L15	VSS57	VSS154	AC11
L24	VSS58	VSS155	AD1
L25	VSS59	VSS156	AD3
L26	VSS60	VSS157	AD4
M1	VSS61	VSS158	AD7
M4	VSS62	VSS159	AD8
M5	VSS63	VSS160	AD11
M12	VSS64	VSS161	AD15
M13	VSS65	VSS162	AD19
M14	VSS66	VSS163	AE2
M15	VSS67	VSS164	AE4
M16	VSS68	VSS165	AE8
M17	VSS69	VSS166	AE11
M24	VSS70	VSS167	AE13
M27	VSS71	VSS168	AE18
M28	VSS72	VSS169	AE21
N1	VSS73	VSS170	AE24
N2	VSS74	VSS171	AF2
N5	VSS75	VSS172	AF4
N6	VSS76	VSS173	AF9
N11	VSS77	VSS174	AF11
N12	VSS78	VSS175	AF27
N13	VSS79	VSS176	AG1
N14	VSS80	VSS177	AG3
N15	VSS81	VSS178	AG7
N16	VSS82	VSS179	AG11
N17	VSS83	VSS180	AG14
N18	VSS84	VSS181	AG17
N24	VSS85	VSS182	AG20
N25	VSS86	VSS183	AG24
N26	VSS87	VSS184	AG25
P2	VSS88	VSS185	AH1
P4	VSS89	VSS186	AH3
P12	VSS90	VSS187	AH7
P13	VSS91	VSS188	AH12
P14	VSS92	VSS189	AH23
P15	VSS93	VSS190	AH27
P16	VSS94	VSS191	AH28
P17	VSS95	VSS192	AH29
P24	VSS96	VSS193	AH31
P27	VSS97	VSS194	AH32

ITL ICH7\_MBGA\_TSB\_652P

<b>INVENTEC</b>			
TITLE <i>San Antonio 10</i>			
ICHT-5			
SIZE <b>A3</b>	CODE <b>CS</b>	DOC. NUMBER <i>TC8703</i>	REV <i>A03</i>
CHANGE by <i>Drawer Name</i>		28-Nov-2005	
SHEET		36	OF 65

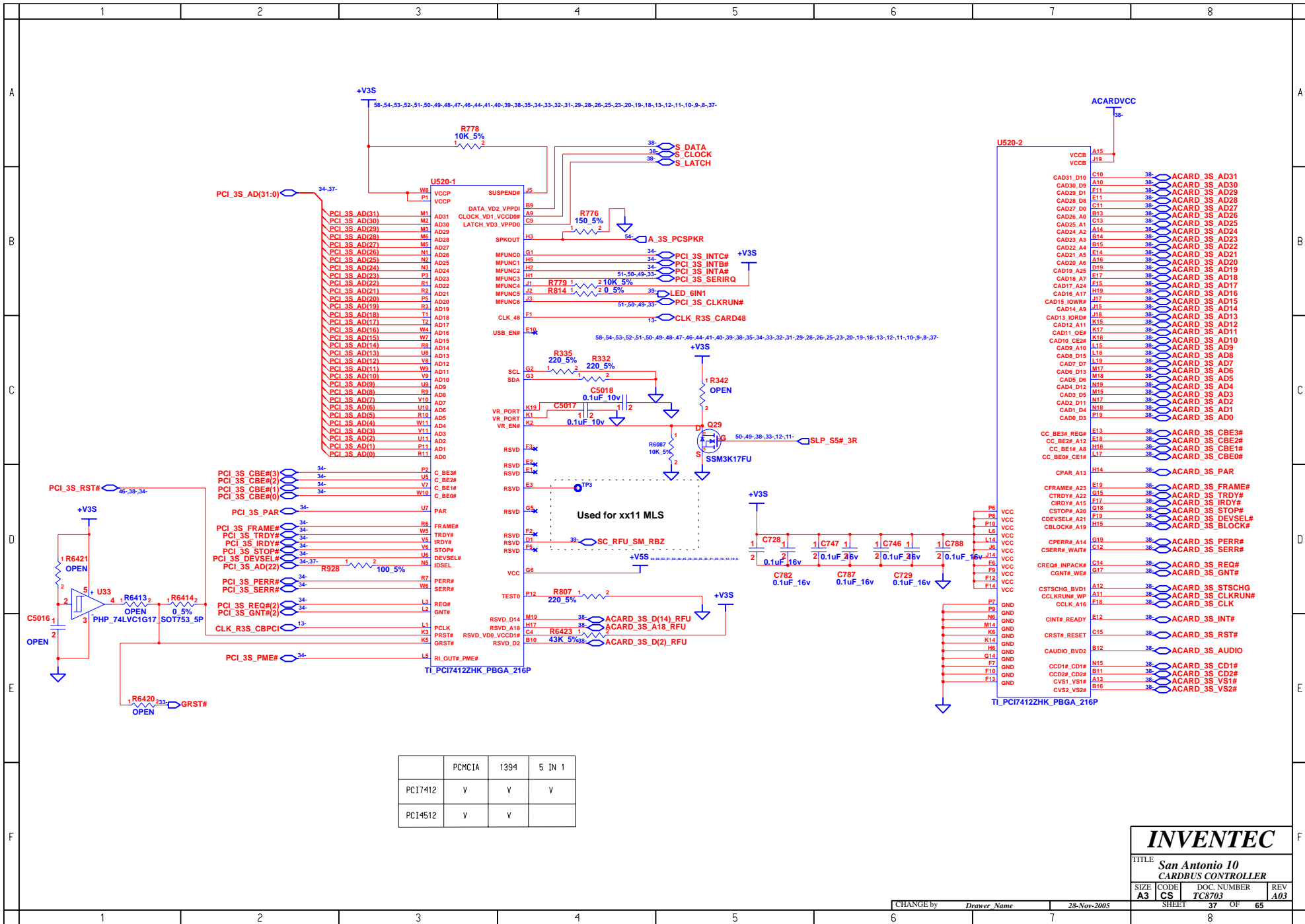

	PCMCIA	1394	5 IN 1
PCI7412	V	V	V
PCI4512	V	V	

**INVENTEC**

TITLE: **San Antonio 10 CARDBUS CONTROLLER**

SIZE	CODE	DOC NUMBER	REV
A3	CS	TC8703	A03

CHANGE by: *Drawer Name* 28-Nov-2005 SHEET 37 OF 65

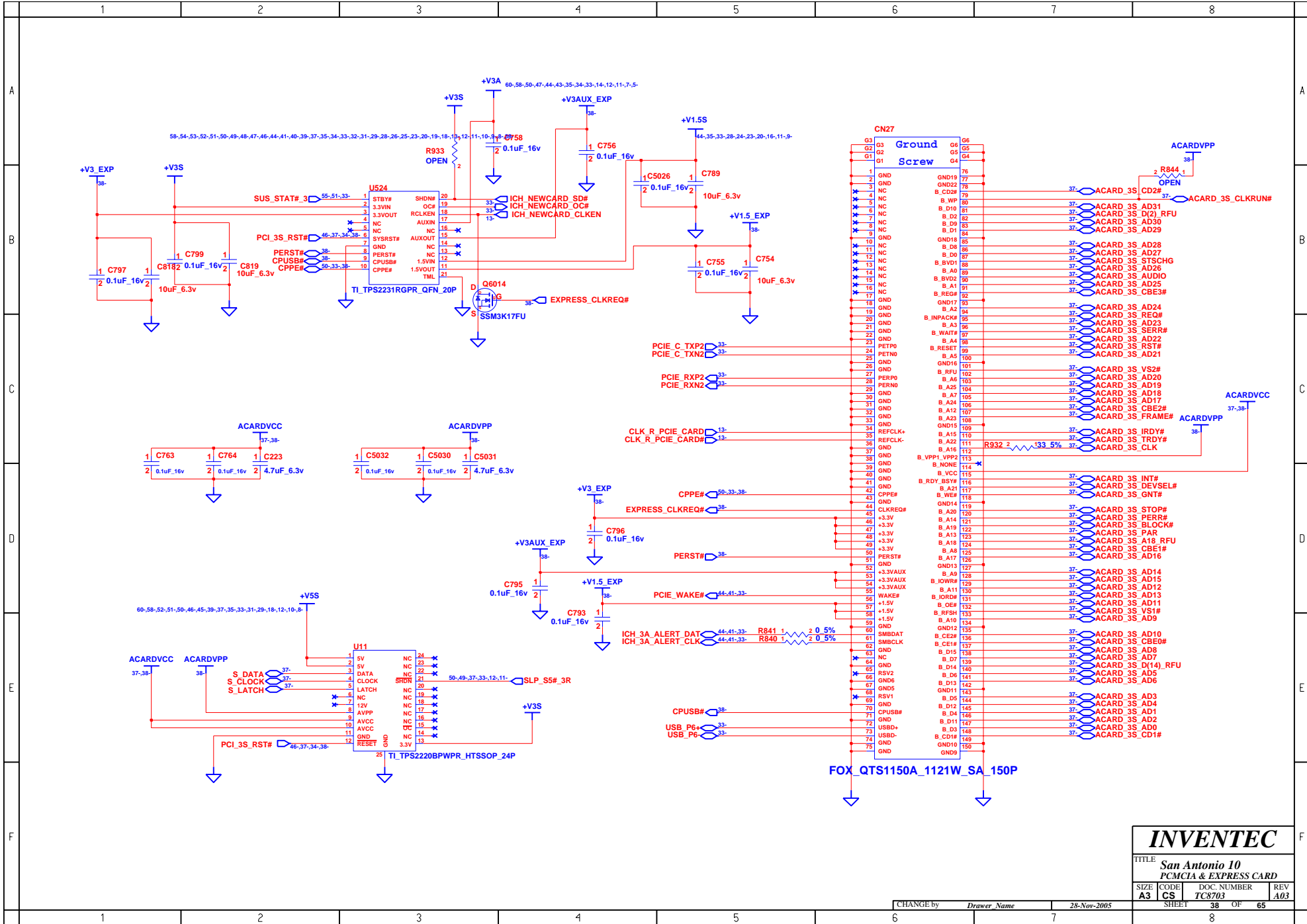

<b>INVENTEC</b>			
TITLE: <b>San Antonio 10 PCMCIA &amp; EXPRESS CARD</b>			
SIZE	CODE	DOC. NUMBER	REV
A3	CS	TC8703	A03
CHANGE by		Drawer Name	28-Nov-2005
SHEET		38	OF 65

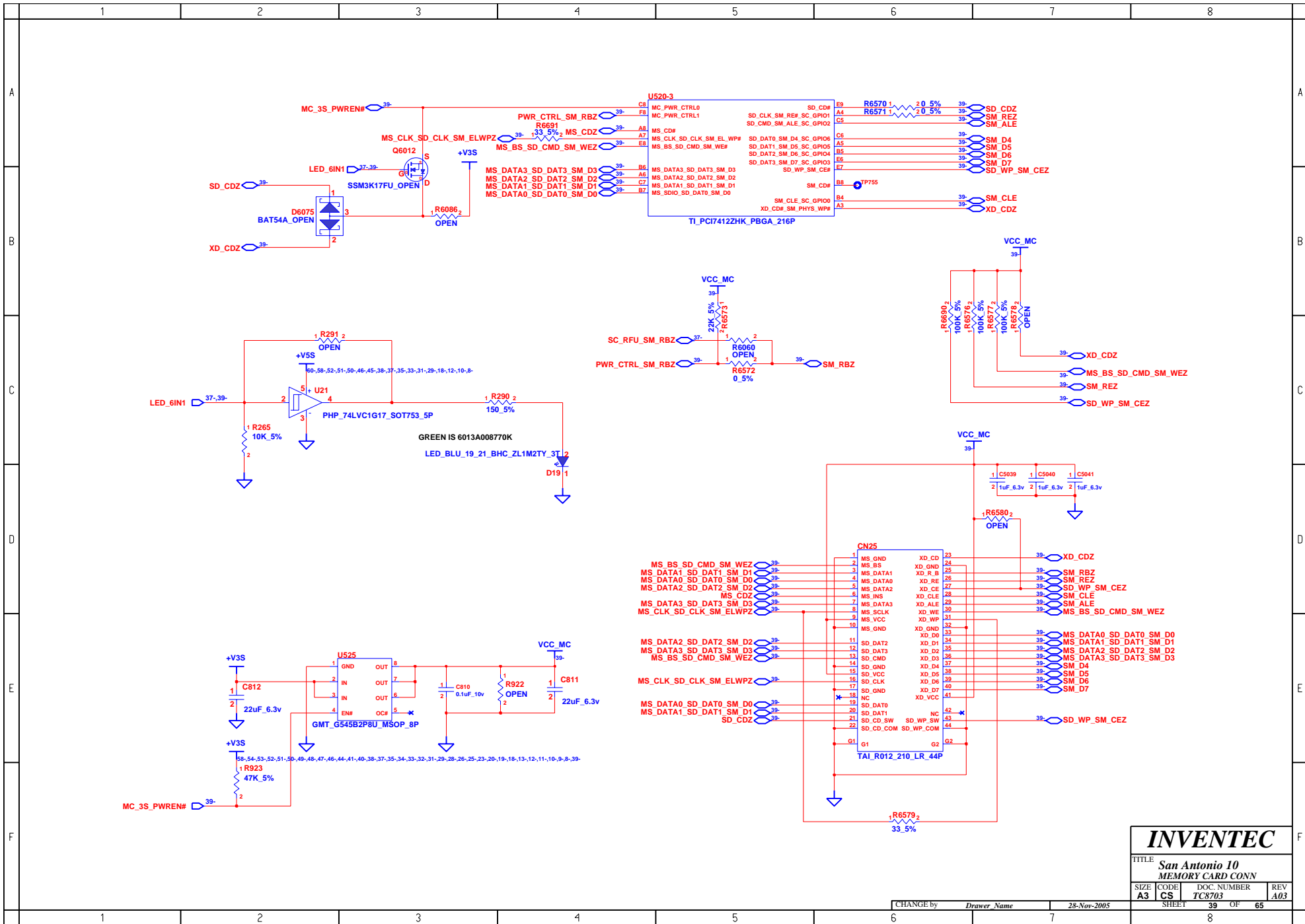

# INVENTEC

TITLE: **San Antonio 10  
MEMORY CARD CONN**

SIZE	CODE	DOC NUMBER	REV
A3	CS	TC8703	A03

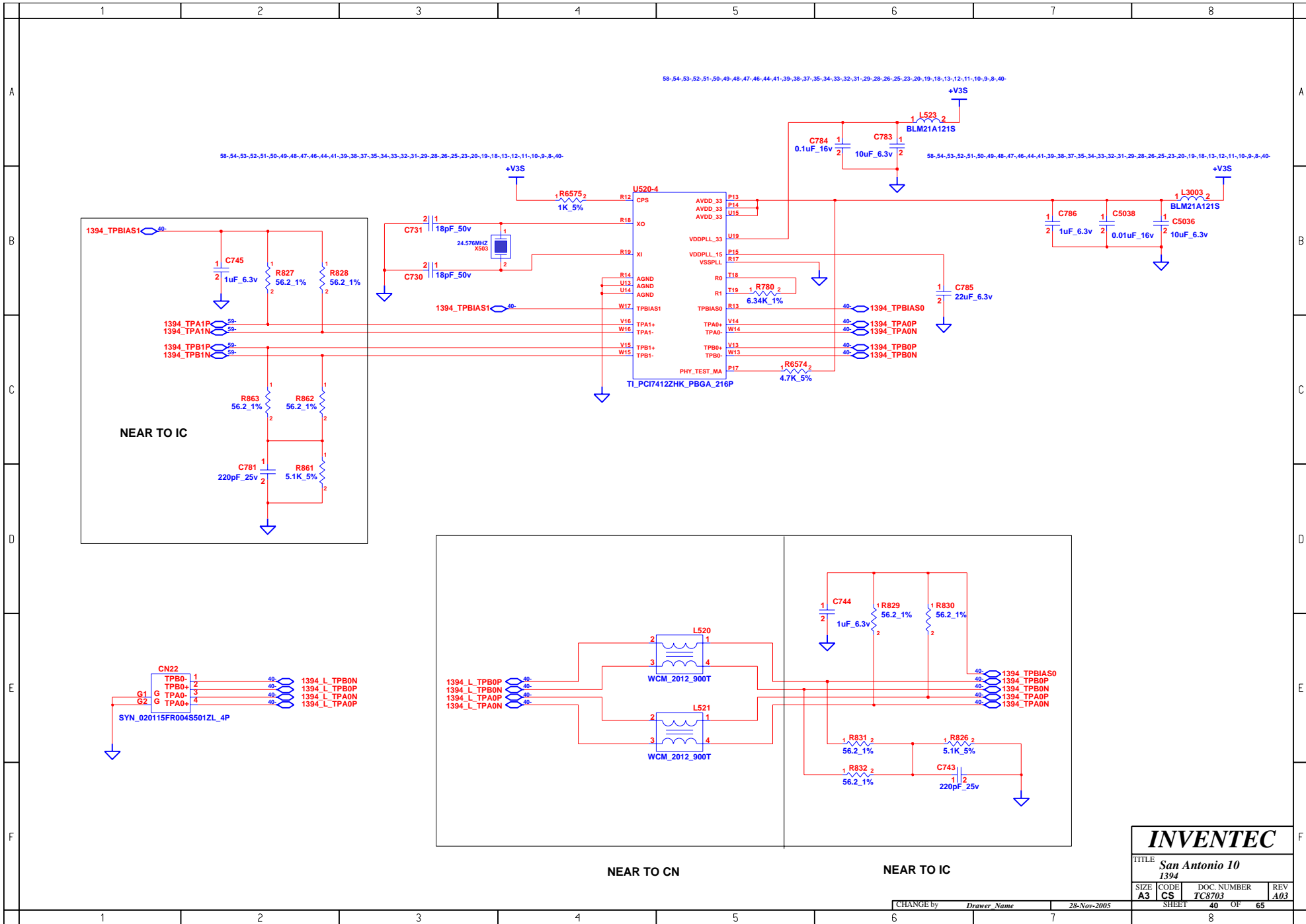

**INVENTEC**

TITLE **San Antonio 10**  
1394

SIZE	CODE	DOC. NUMBER	REV
A3	CS	TC8703	A03

CHANGE by *Drawer Name* 28-Nov-2005

SHEET 40 OF 65



" T " stuffed for Tekoa  
 " E " stuffed for EkronR

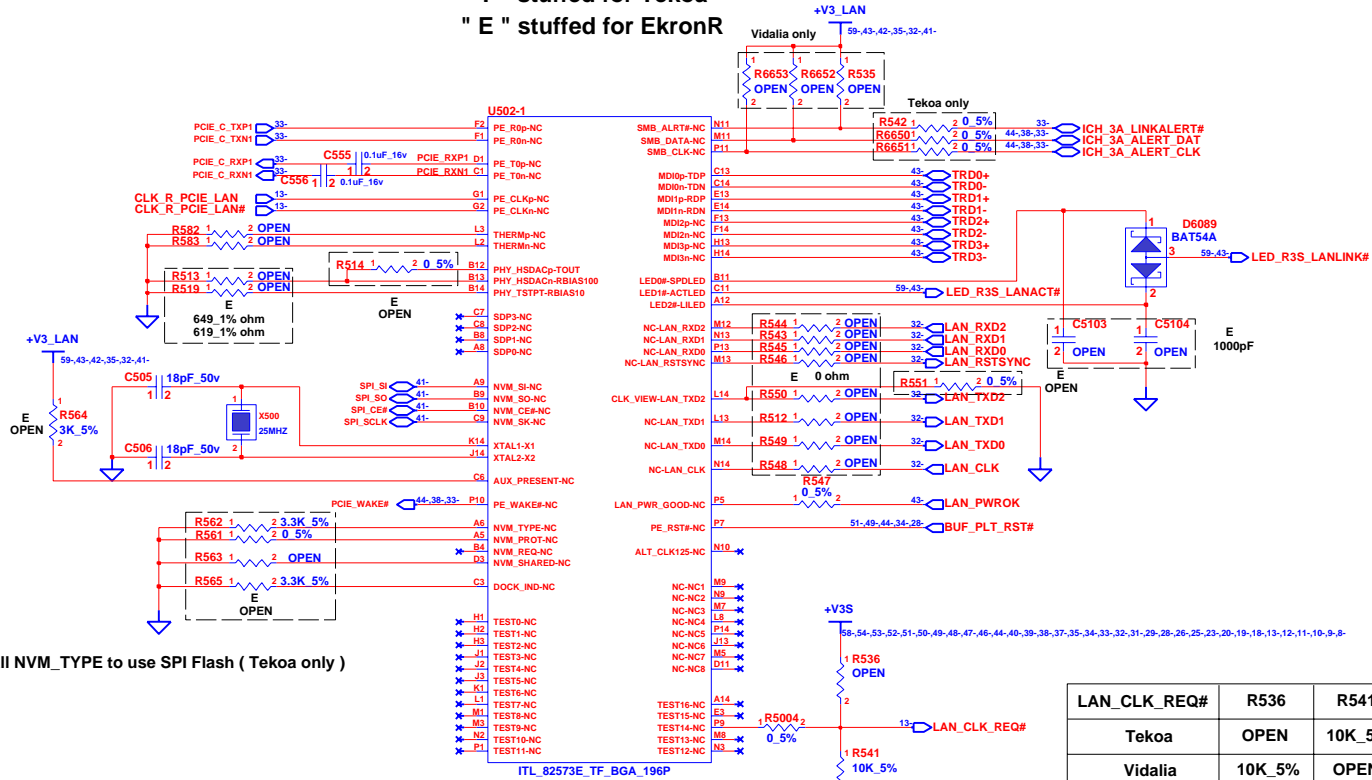

Install NVM\_TYPE to use SPI Flash ( Tekoa only )

LAN_CLK_REQ#	R536	R541	R5004
Tekoa	OPEN	10K_5%	OPEN
Vidalia	10K_5%	OPEN	0_5%
EkronR	10K_5%	OPEN	OPEN

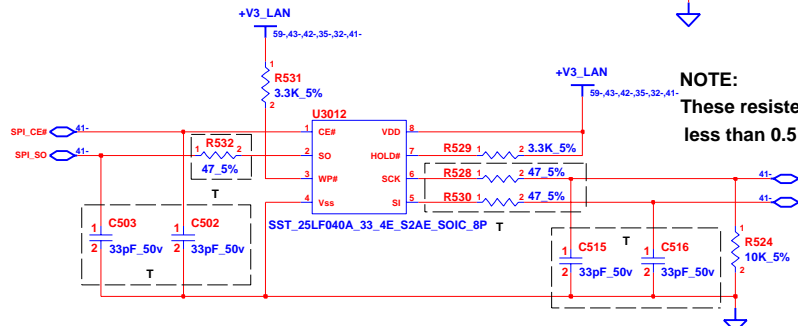

NOTE:  
 These caps should be placed less than 0.5" from the LAN Controller

NOTE:  
 These resistors should be placed less than 0.5" from the SPI Flash

**INVENTEC**

TITLE: San Antonio 10  
 LAN INTERFACE-1

SIZE	CODE	DOC. NUMBER	REV
A3	CS	TC8703	A03

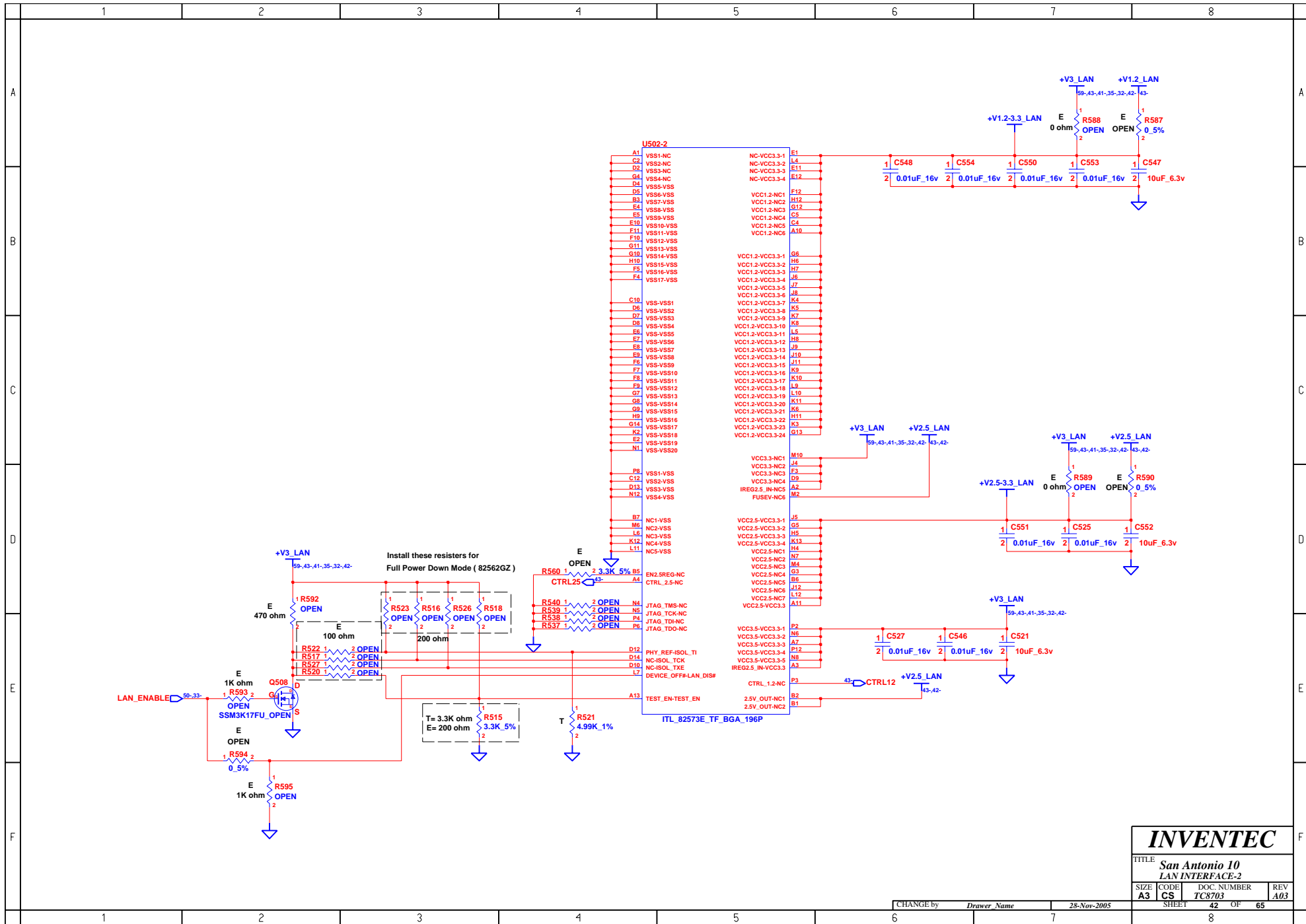

<b>INVENTEC</b>			
TITLE: San Antonio 10 LAN INTERFACE-2			
SIZE: A3	CODE: CS	DOC. NUMBER: TC8703	REV: A03
CHANGE by: Drawer Name		28-Nov-2005	SHEET 42 OF 65



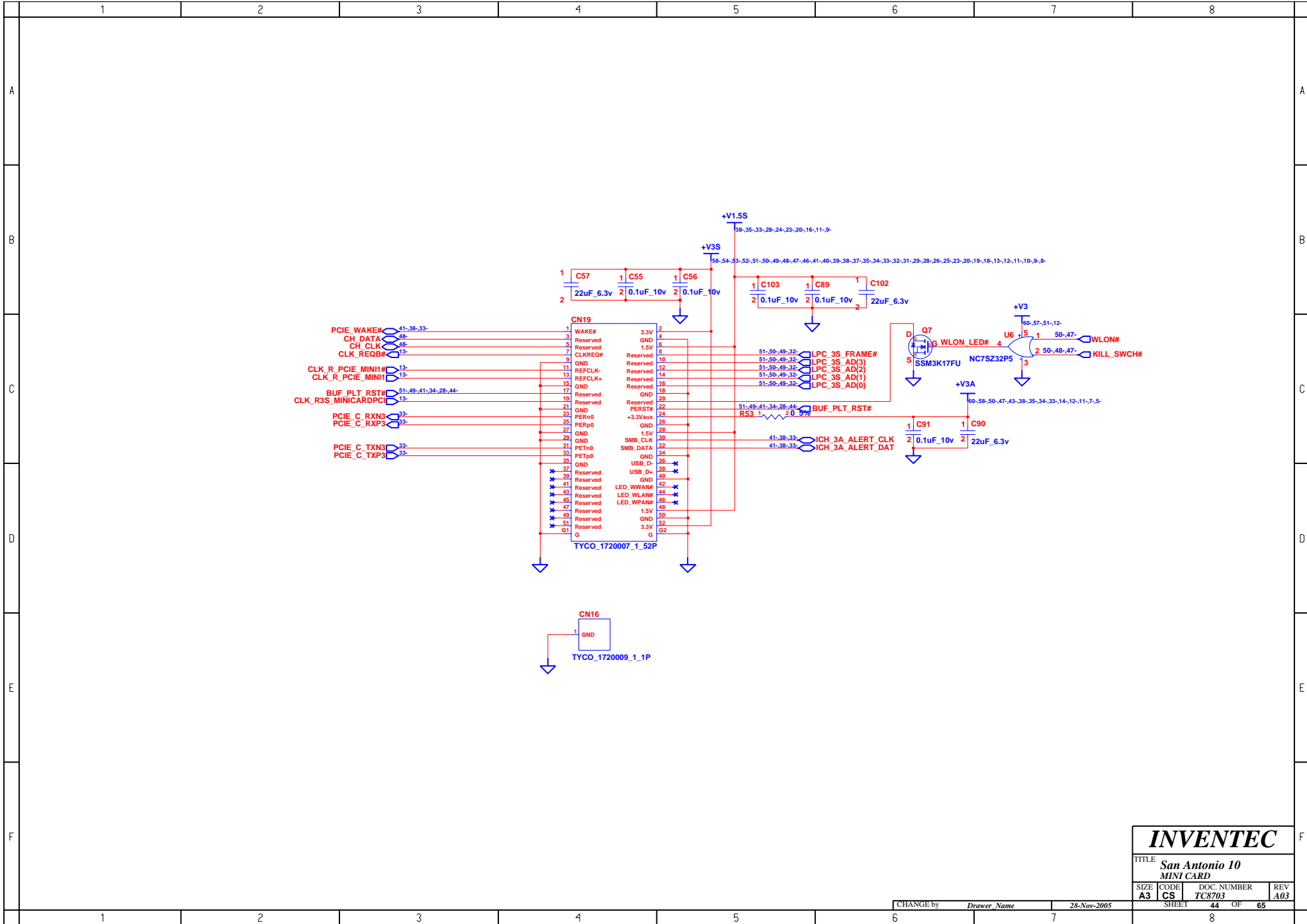

# INVENTEC

TITLE **San Antonio 10  
MINI CARD**

SIZE <b>A3</b>	CODE <b>CS</b>	DOC. NUMBER <b>TC8703</b>	REV <b>A03</b>
-------------------	-------------------	------------------------------	-------------------

CHANGE by *Drawer Name* 28-Nov-2005

SHEET 44 OF 65

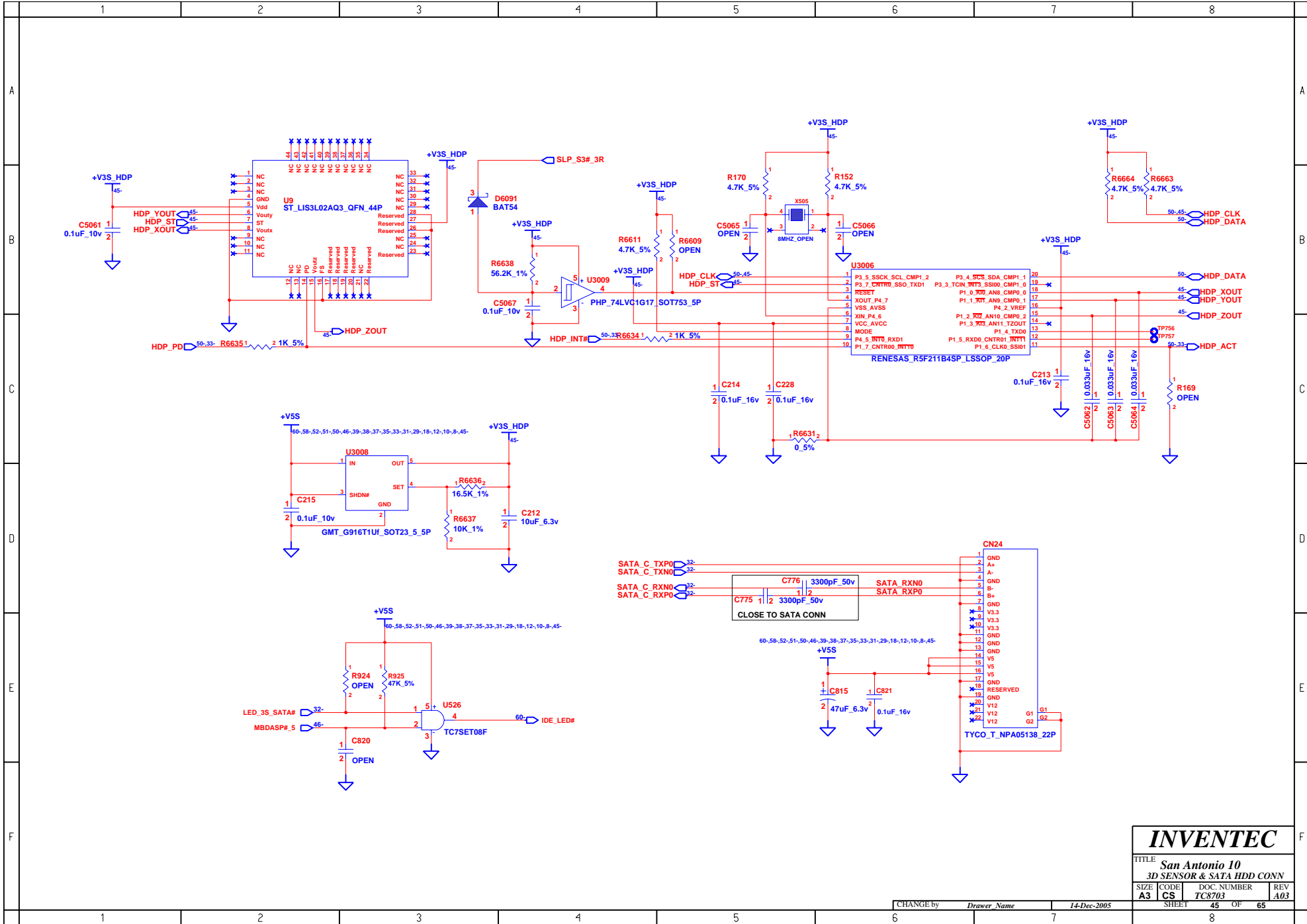

<b>INVENTEC</b>			
TITLE <b>San Antonio 10</b>			
3D SENSOR & SATA HDD CONN			
SIZE	CODE	DOC NUMBER	REV
A3	CS	TC8703	A03

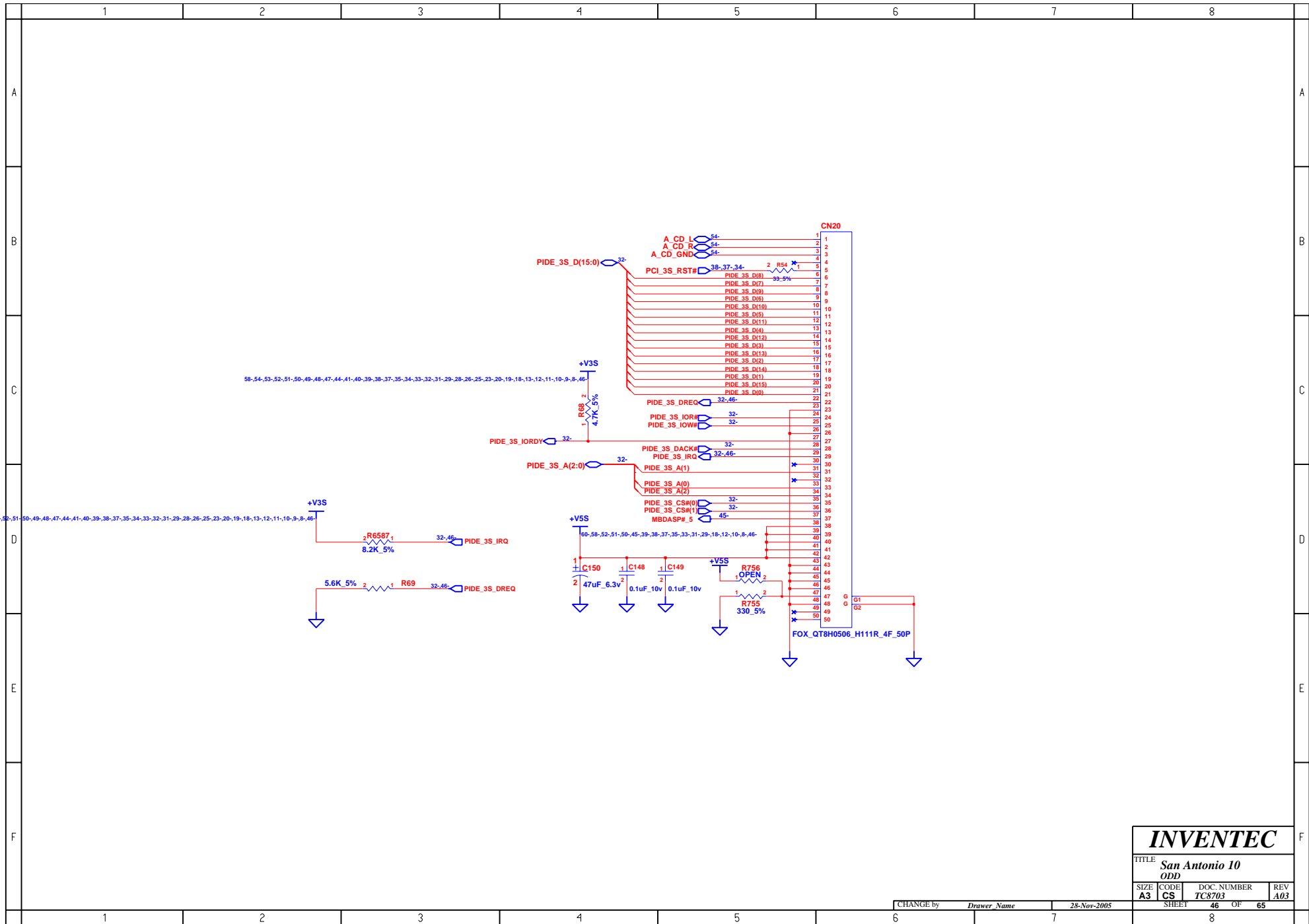

<b>INVENTEC</b>			
TITLE <i>San Antonio 10</i>			
ODD			
SIZE <b>A3</b>	CODE <b>CS</b>	DOC. NUMBER <i>TC8703</i>	REV <b>A03</b>
CHANGE by <i>Drawer Name</i>		28-Nov-2005	SHEET 46 OF 65

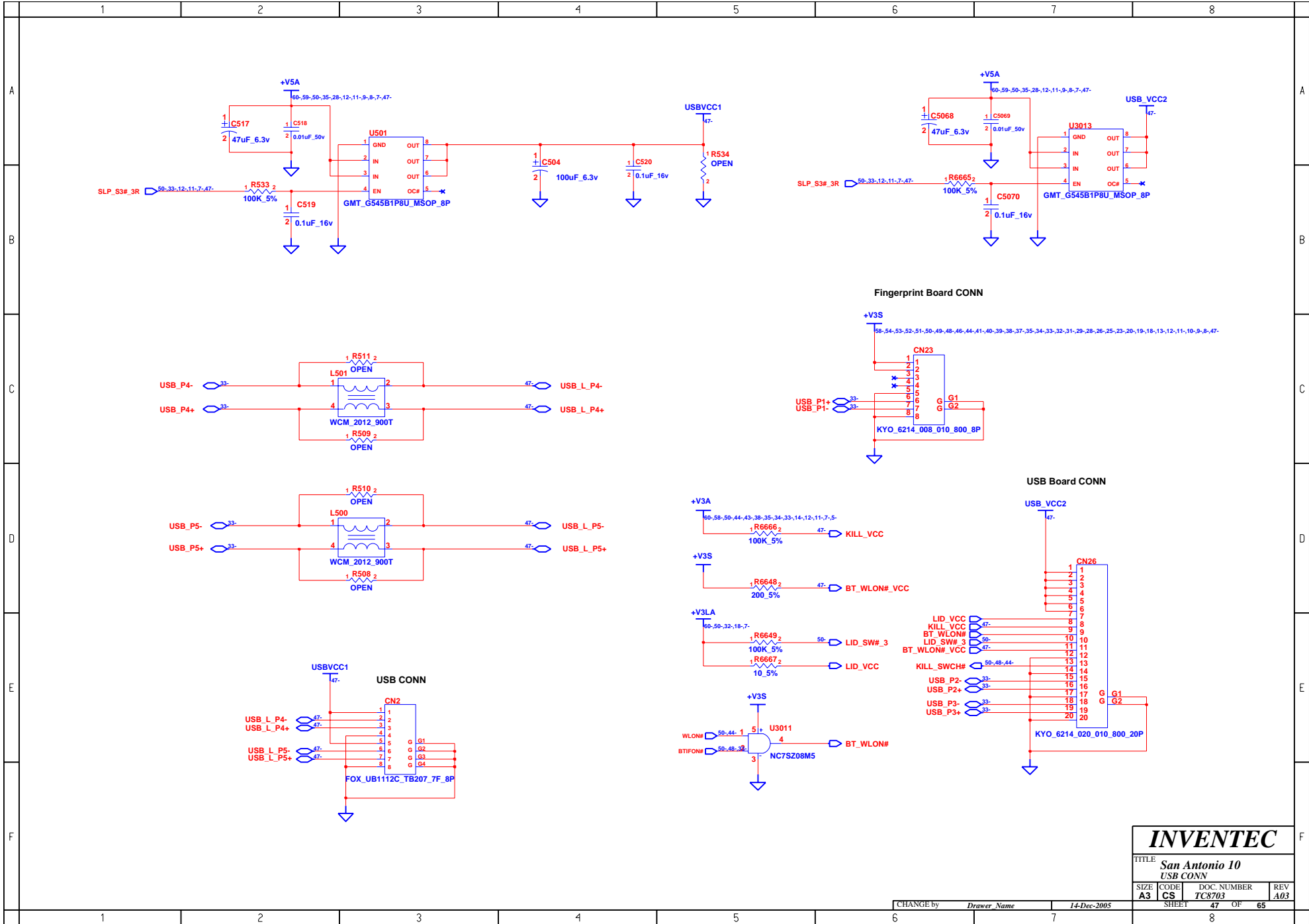

<b>INVENTEC</b>			
TITLE <b>San Antonio 10</b> USB CONN			
SIZE <b>A3</b>	CODE <b>CS</b>	DOC. NUMBER <b>TC8703</b>	REV <b>A03</b>
CHANGE by <i>Drawer Name</i>		14-Dec-2005	SHEET 47 OF 65

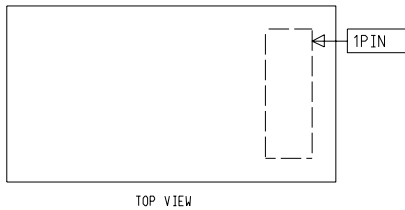
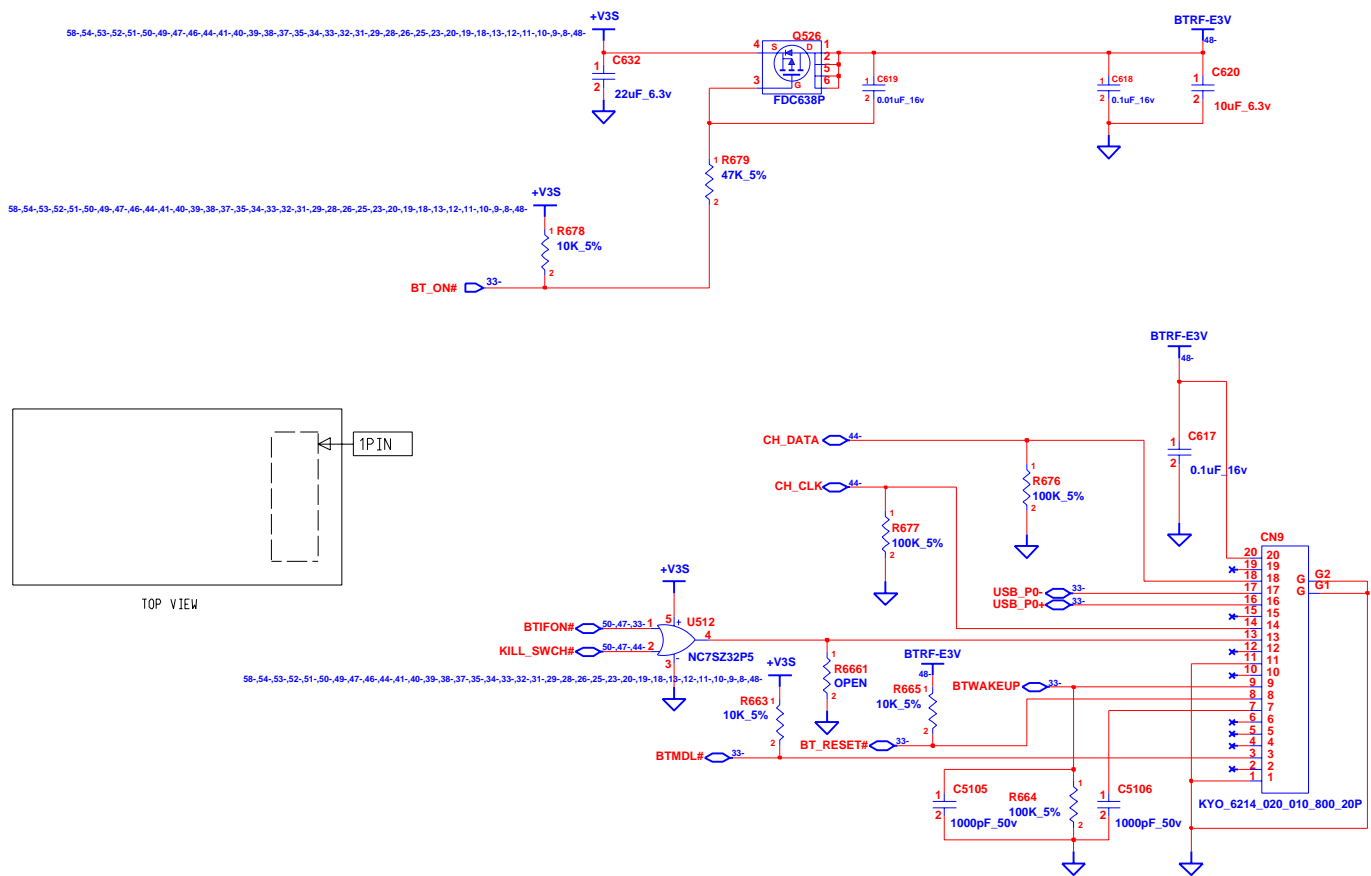

BTMDL #

L	HAVE BLUETOOTH MODULE
H	NO BLUETOOTH MODULE

**INVENTEC**

TITLE **San Antonio 10 BLUETOOTH**

SIZE <b>A3</b>	CODE <b>CS</b>	DOC. NUMBER <b>TC8703</b>	REV <b>A03</b>
----------------	----------------	---------------------------	----------------



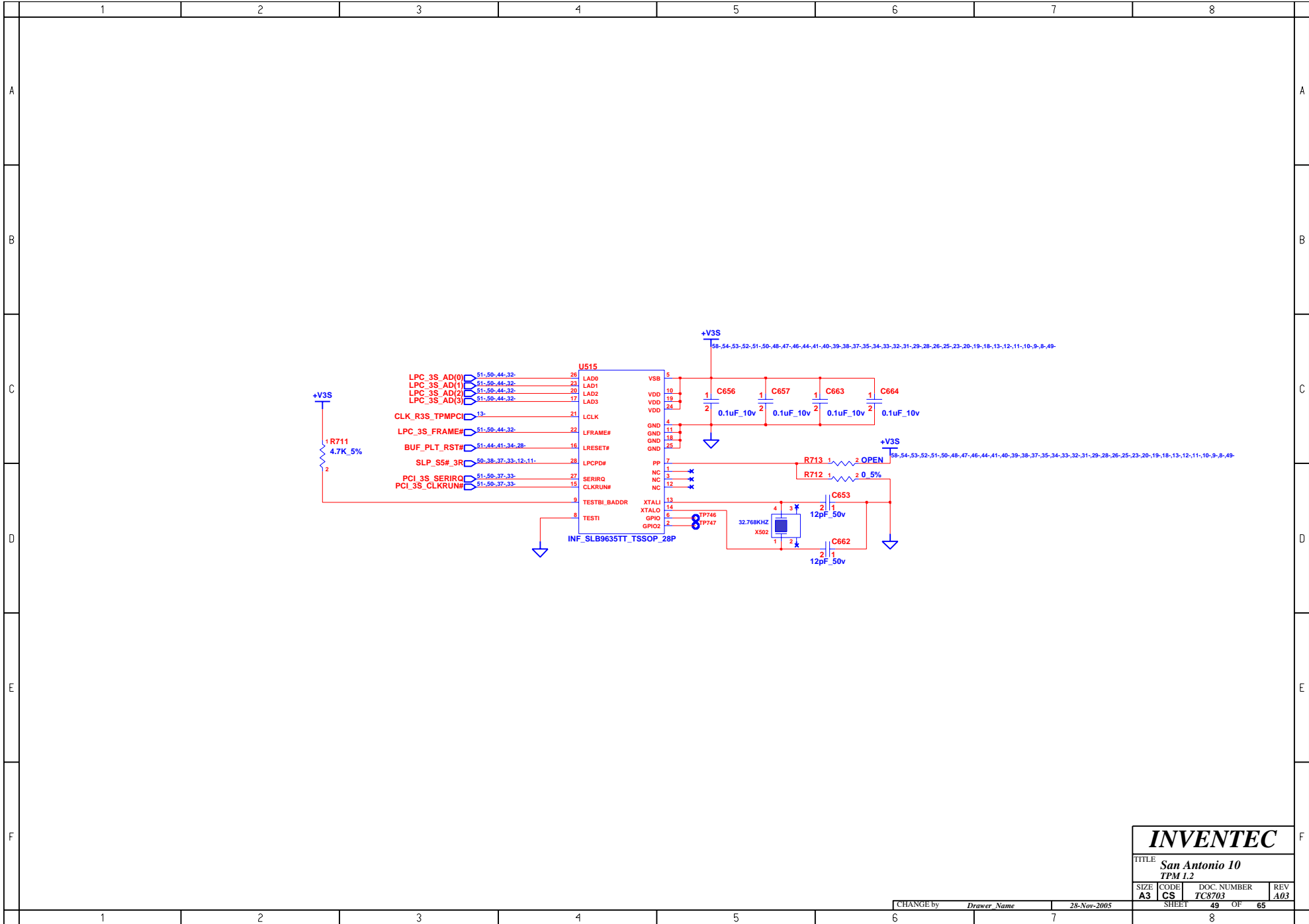

# INVENTEC

TITLE **San Antonio 10**  
**TPM 1.2**

SIZE <b>A3</b>	CODE <b>CS</b>	DOC. NUMBER <b>TC8703</b>	REV <b>A03</b>
----------------	----------------	---------------------------	----------------

CHANGE by *Drawer Name* 28-Nov-2005

SHEET 49 OF 65



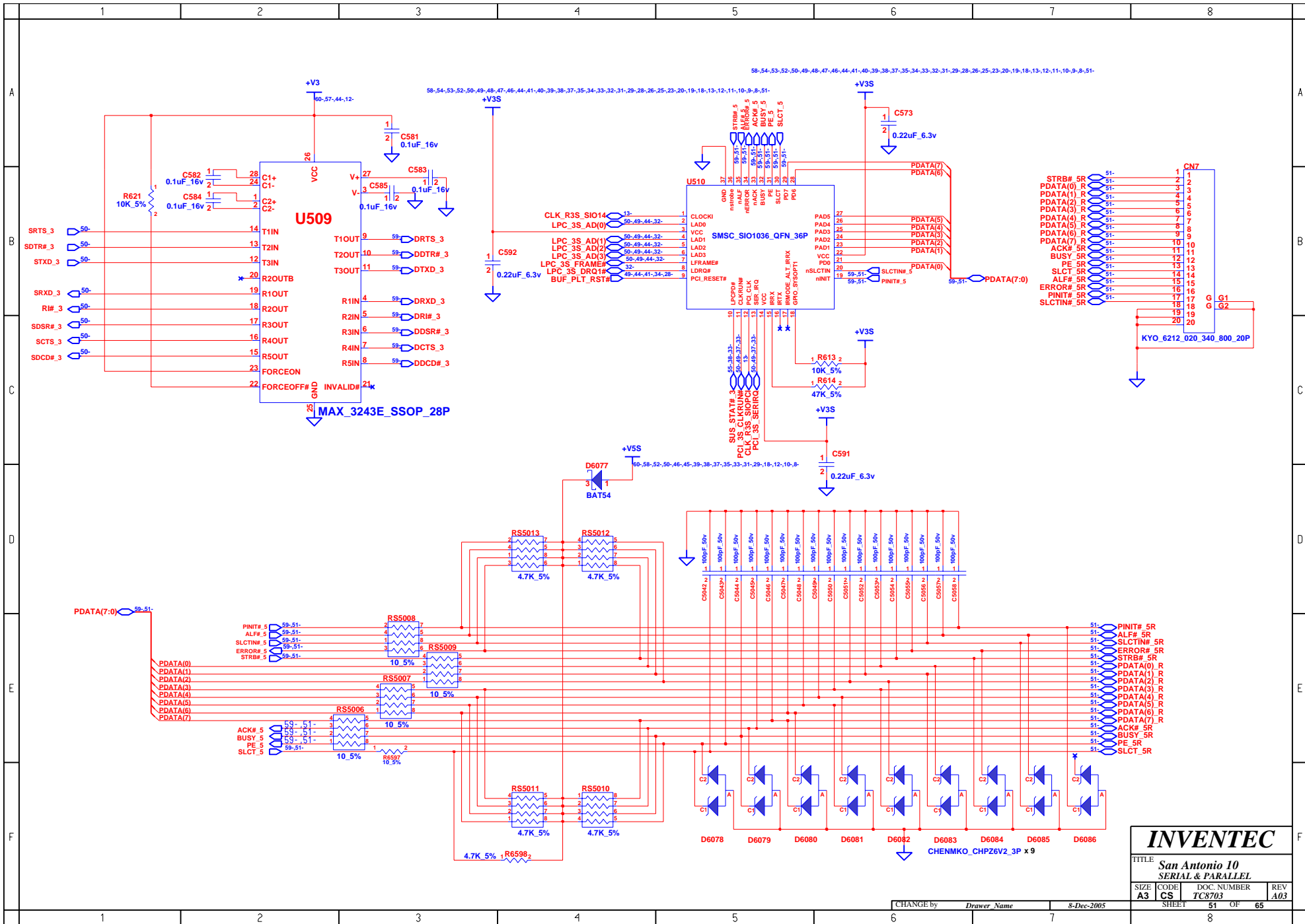

**INVENTEC**

TITLE: **San Antonio 10 SERIAL & PARALLEL**

SIZE	CODE	DOC NUMBER	REV
A3	CS	TC8703	A03

SHEET 51 OF 65

CHANGE by *Drawer Name* 8-Dec-2005

D6078 D6079 D6080 D6081 D6082 D6083 D6084 D6085 D6086  
 CHENMKO\_CHPZ6V2\_3P x 9

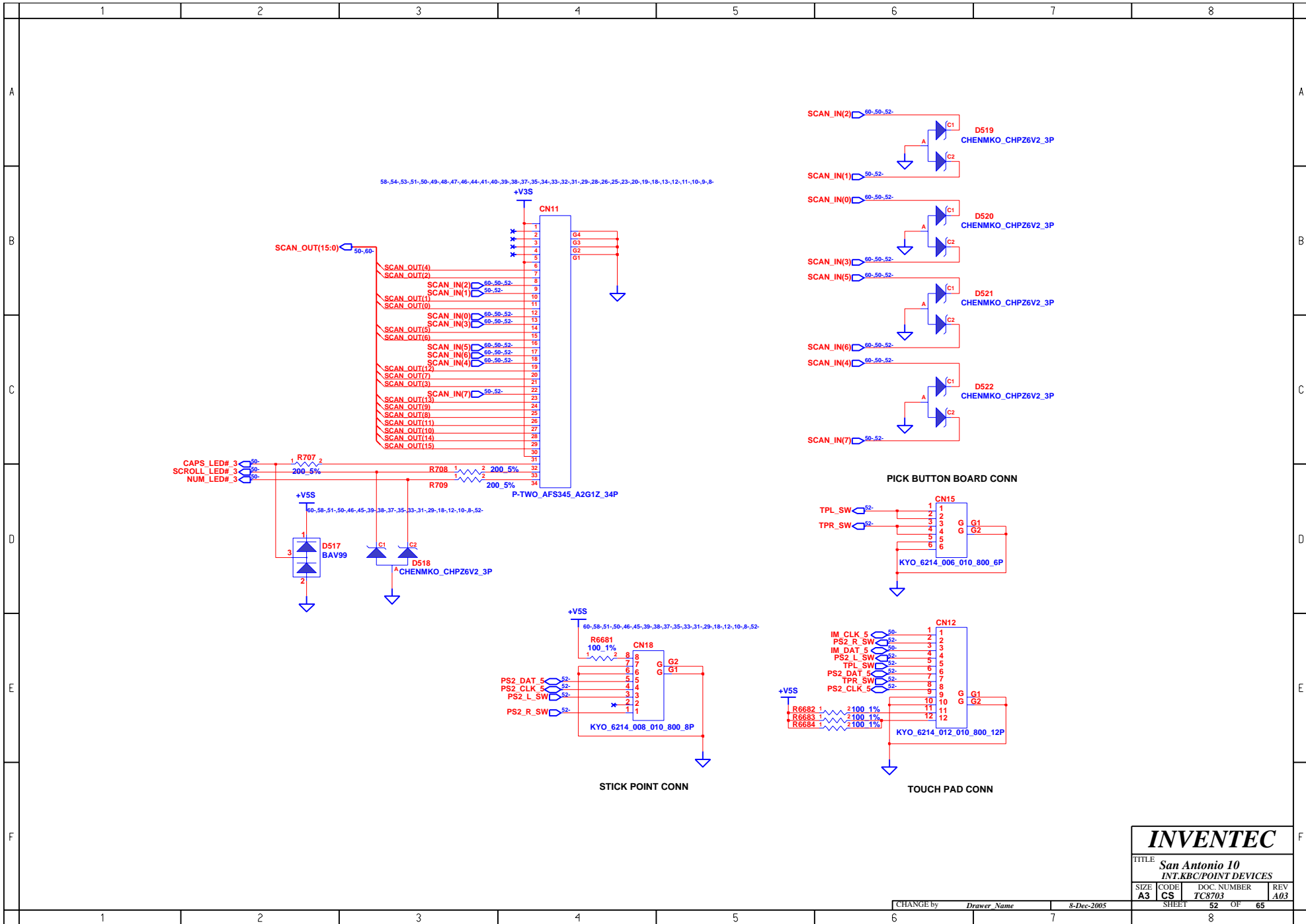

# INVENTEC

TITLE **San Antonio 10**  
INT.KBC/POINT DEVICES

SIZE <b>A3</b>	CODE <b>CS</b>	DOC. NUMBER <b>TC8703</b>	REV <b>A03</b>
-------------------	-------------------	------------------------------	-------------------

CHANGE by *Drawer Name* 8-Dec-2005

SHEET 52 OF 65

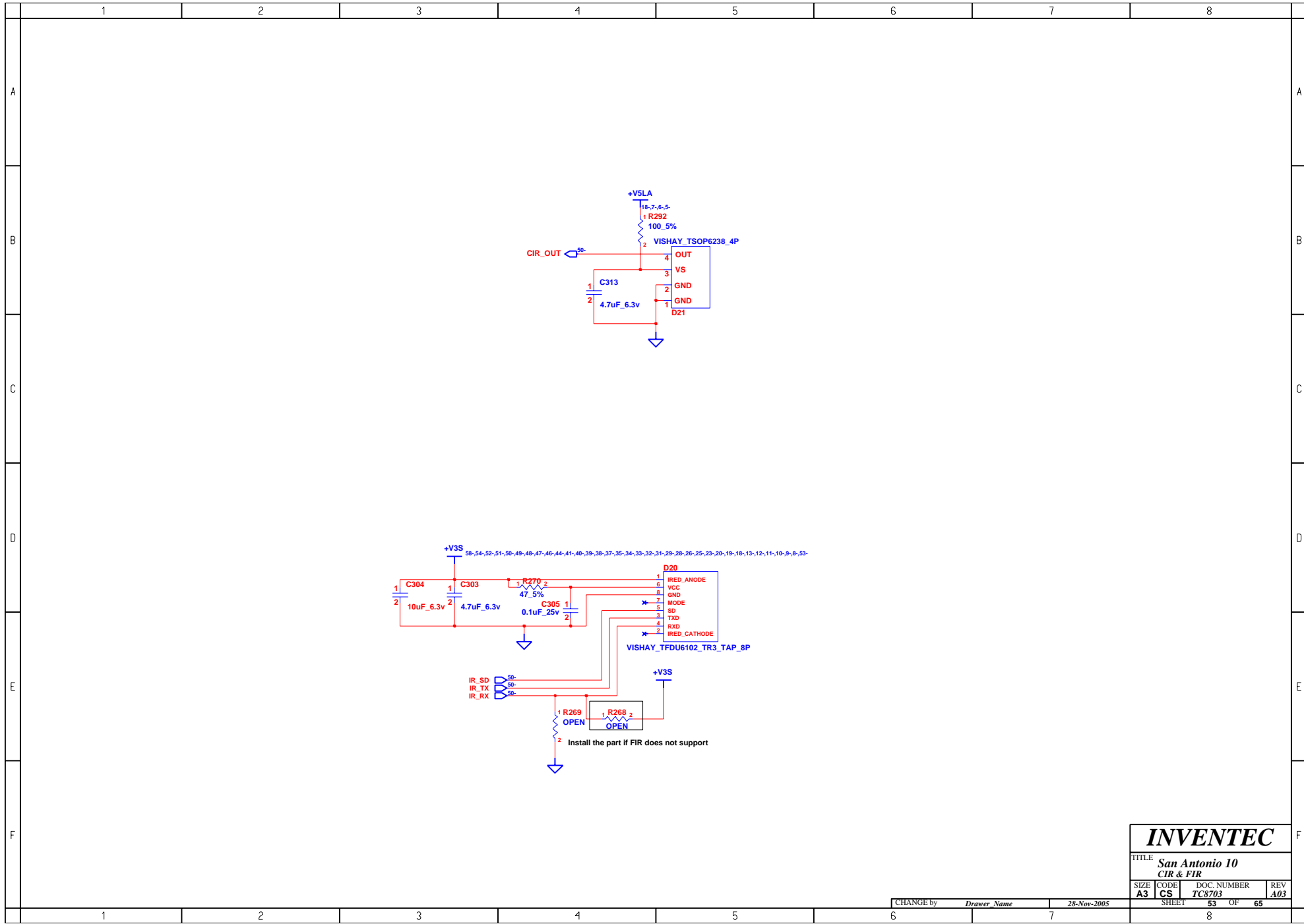

**INVENTEC**

TITLE *San Antonio 10*  
*CIR & FIR*

SIZE <b>A3</b>	CODE <b>CS</b>	DOC. NUMBER <b>TC8703</b>	REV <b>A03</b>
-------------------	-------------------	------------------------------	-------------------

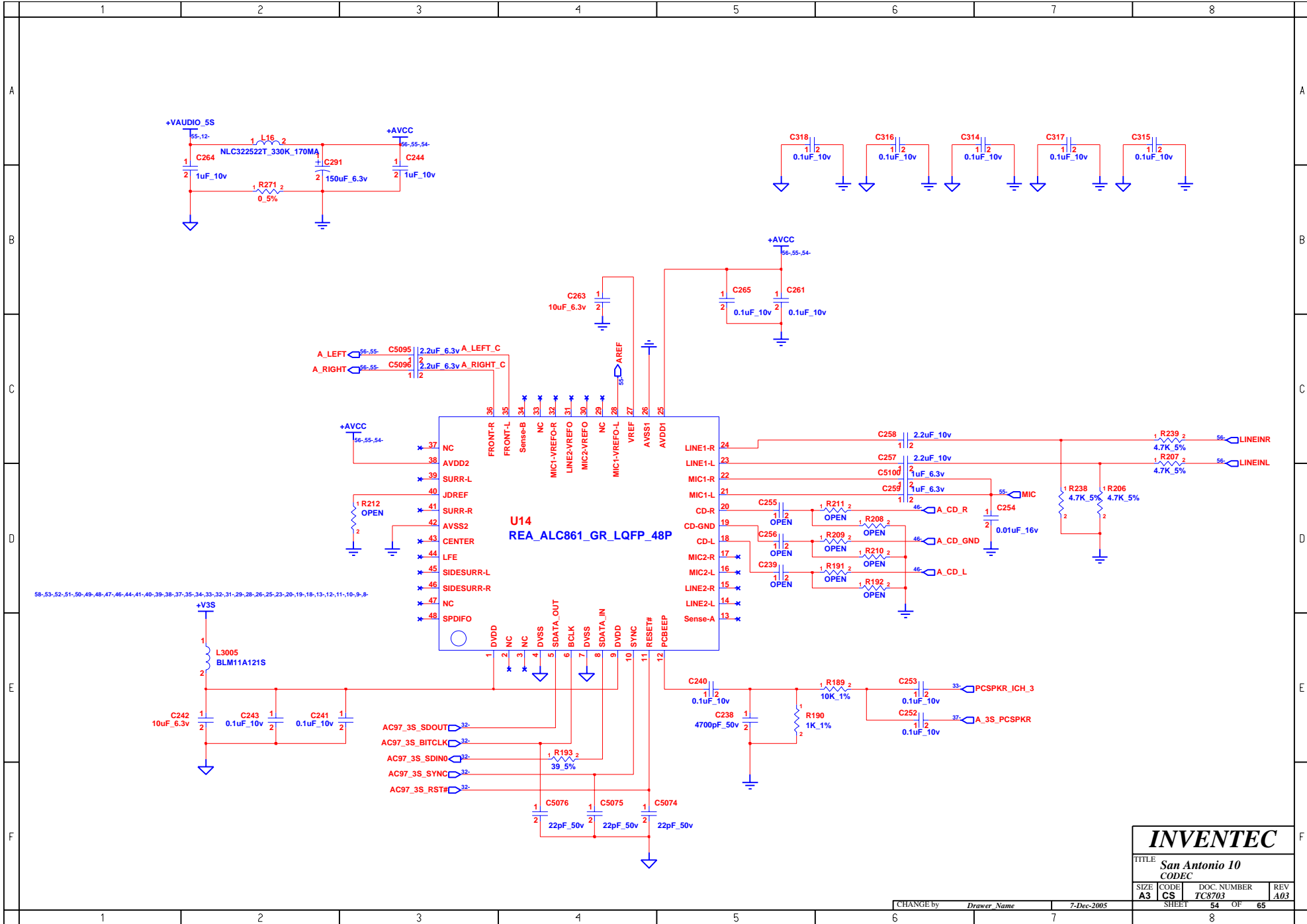

<b>INVENTEC</b>			
TITLE <b>San Antonio 10 CODEC</b>			
SIZE <b>A3</b>	CODE <b>CS</b>	DOC. NUMBER <b>TC8703</b>	REV <b>A03</b>
SHEET 54 OF 65			

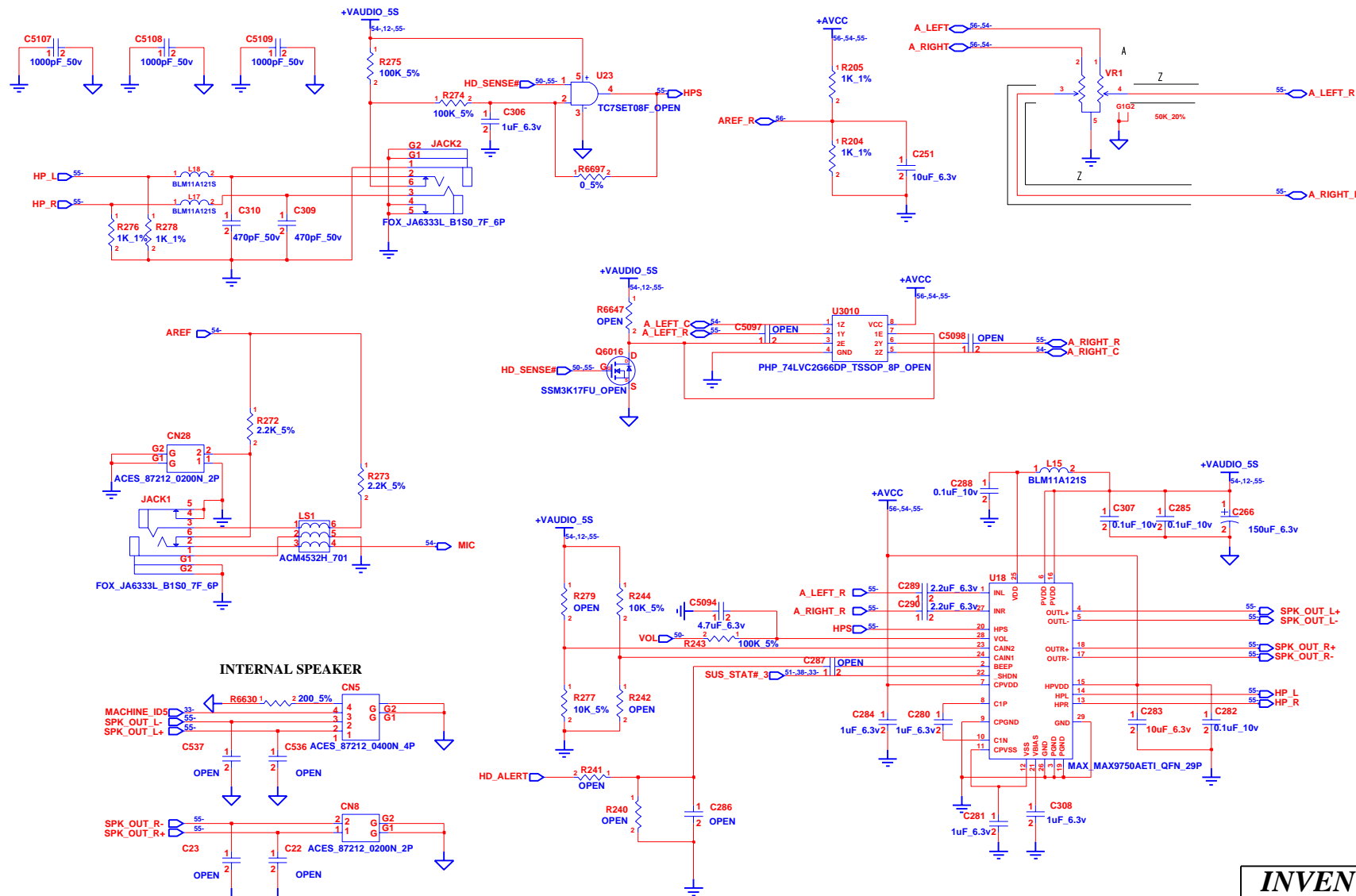

**INTERNAL SPEAKER**

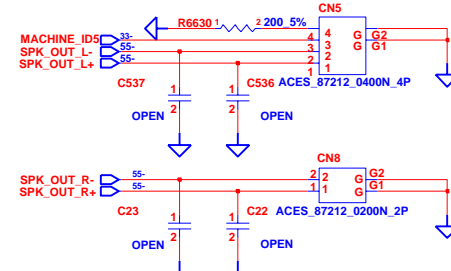

**INVENTEC**

TITLE: **San Antonio 10  
AMP & MIC & HP**

SIZE	CODE	DOC. NUMBER	REV
A3	CS	TC8703	A03

CHANGE: by *Drawer\_Name* 15-Dec-2005 SHEET 55 OF 65

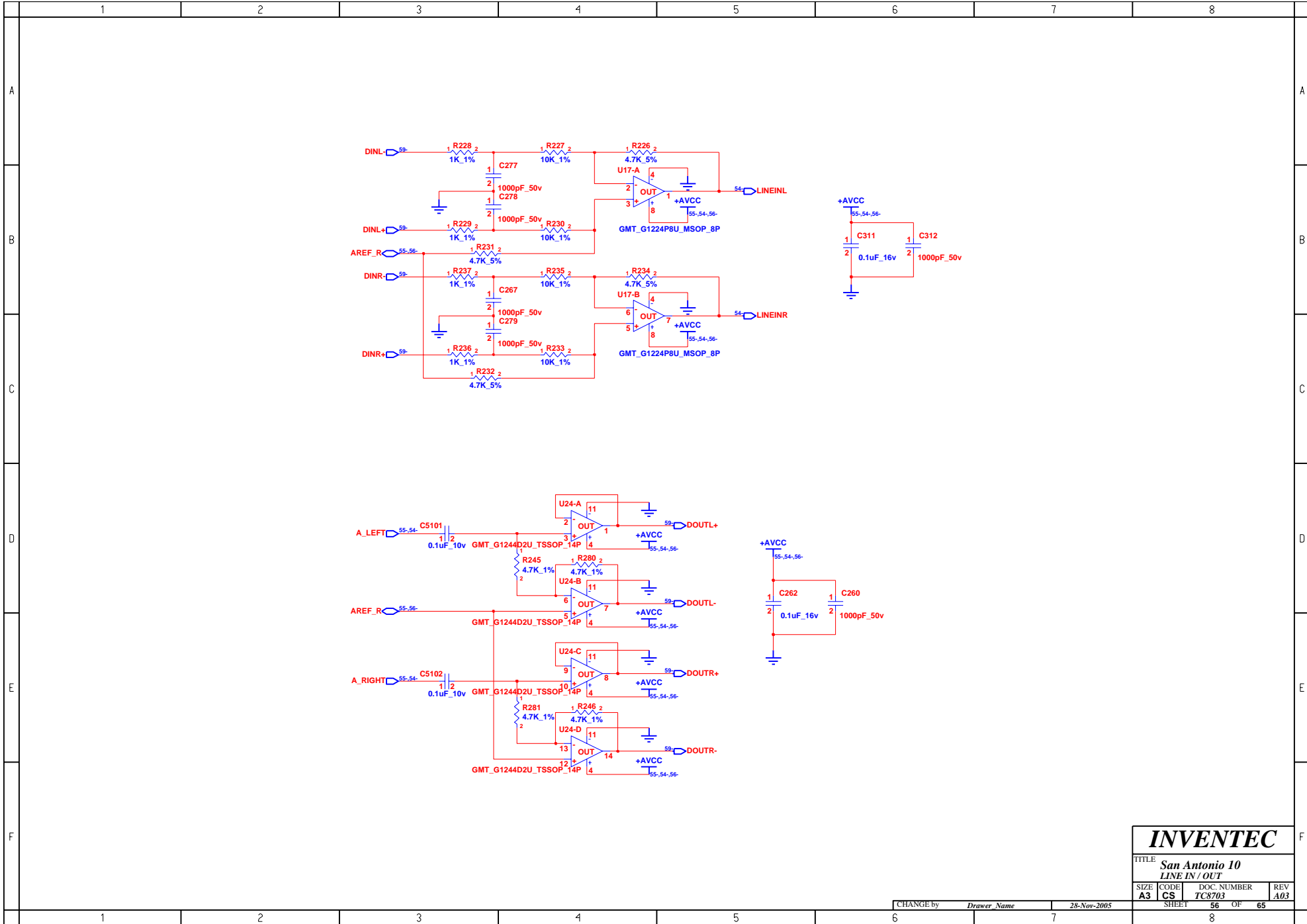

# INVENTEC

TITLE **San Antonio 10**  
**LINE IN / OUT**

SIZE <b>A3</b>	CODE <b>CS</b>	DOC. NUMBER <b>TC8703</b>	REV <b>A03</b>
-------------------	-------------------	------------------------------	-------------------



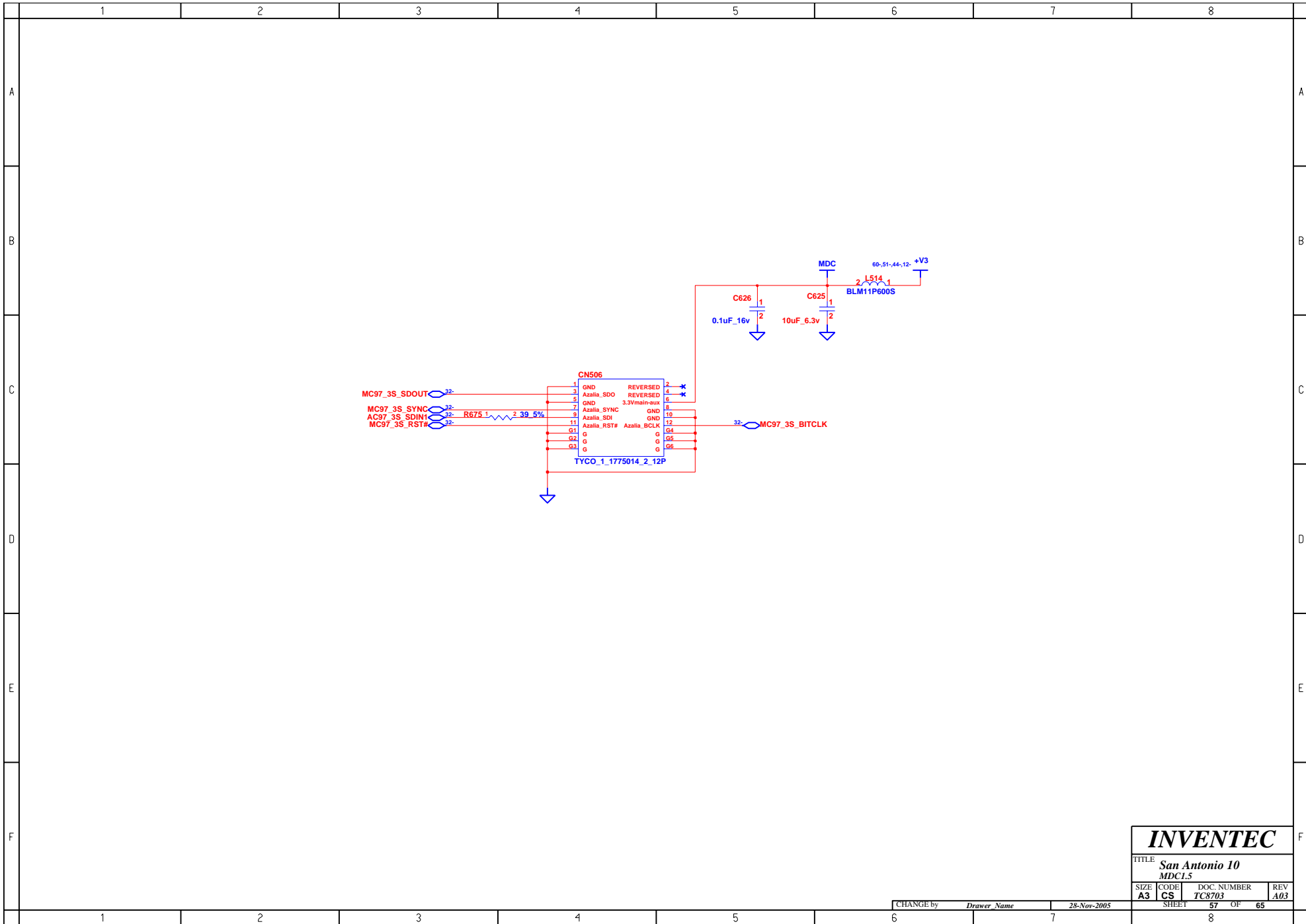

**INVENTEC**

TITLE *San Antonio 10*  
MDC1.5

SIZE	CODE	DOC. NUMBER	REV
A3	CS	TC8703	A03

CHANGE by *Drawer Name* 28-Nov-2005

SHEET 57 OF 65

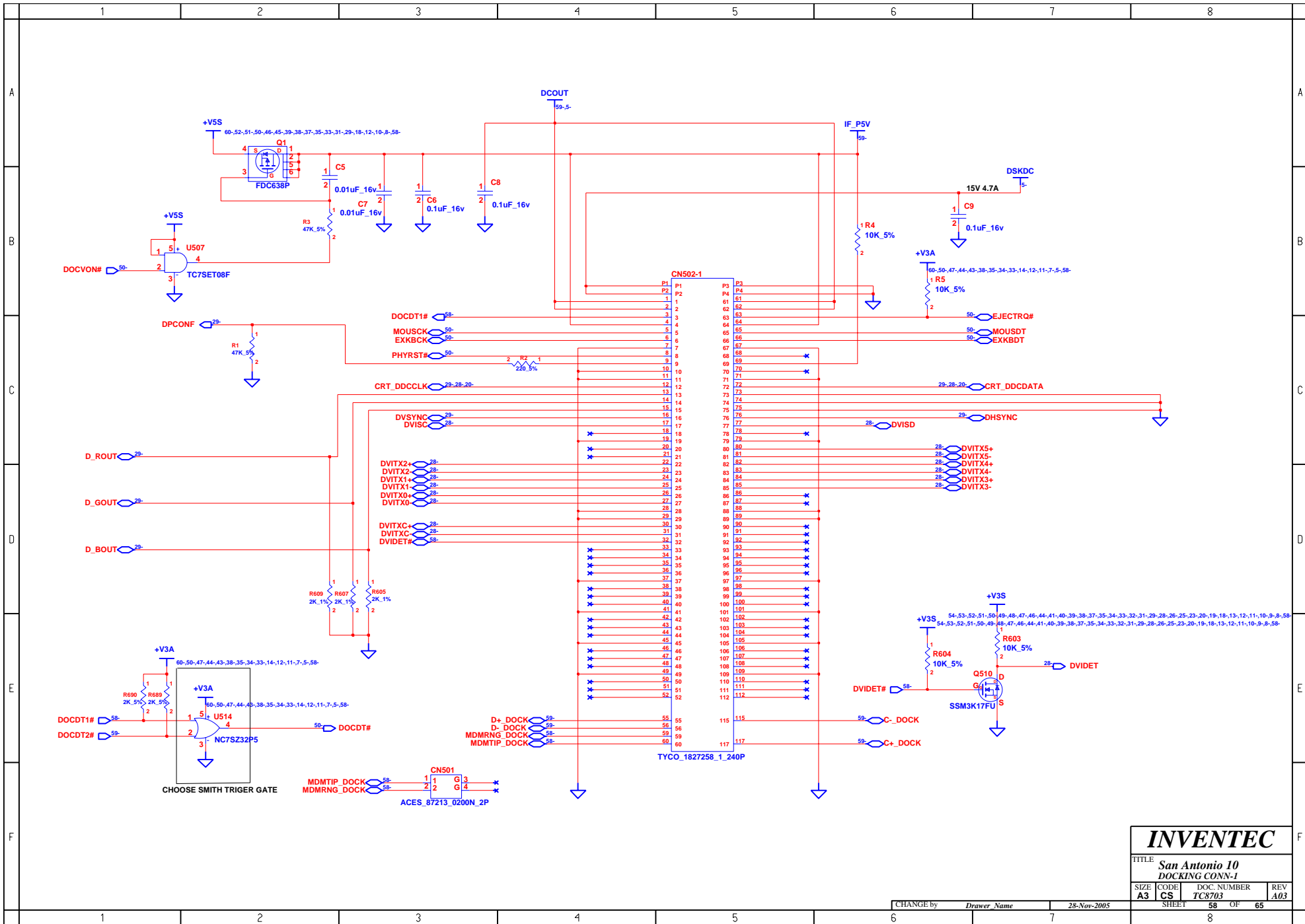

<b>INVENTEC</b>			
TITLE <b>San Antonio 10 DOCKING CONN-1</b>			
SIZE <b>A3</b>	CODE <b>CS</b>	DOC. NUMBER <b>TC8703</b>	REV <b>A03</b>
CHANGE by <i>Drawer Name</i>		28-Nov-2005	SHEET <b>58</b> OF <b>65</b>

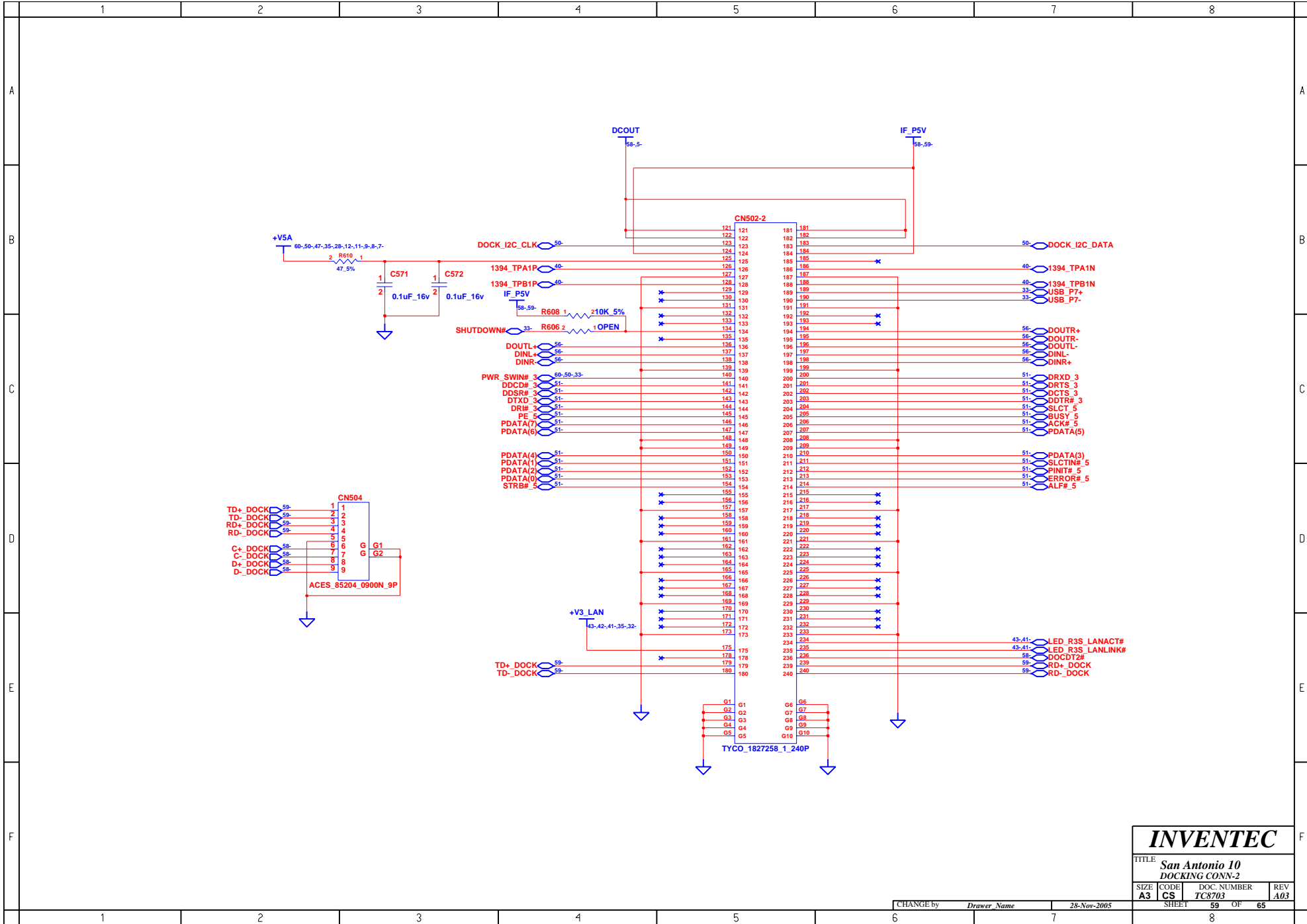

# INVENTEC

TITLE **San Antonio 10 DOCKING CONN-2**

SIZE	CODE	DOC. NUMBER	REV
A3	CS	TC8703	A03

CHANGE by *Drawer Name* 28-Nov-2005 SHEET 59 OF 65

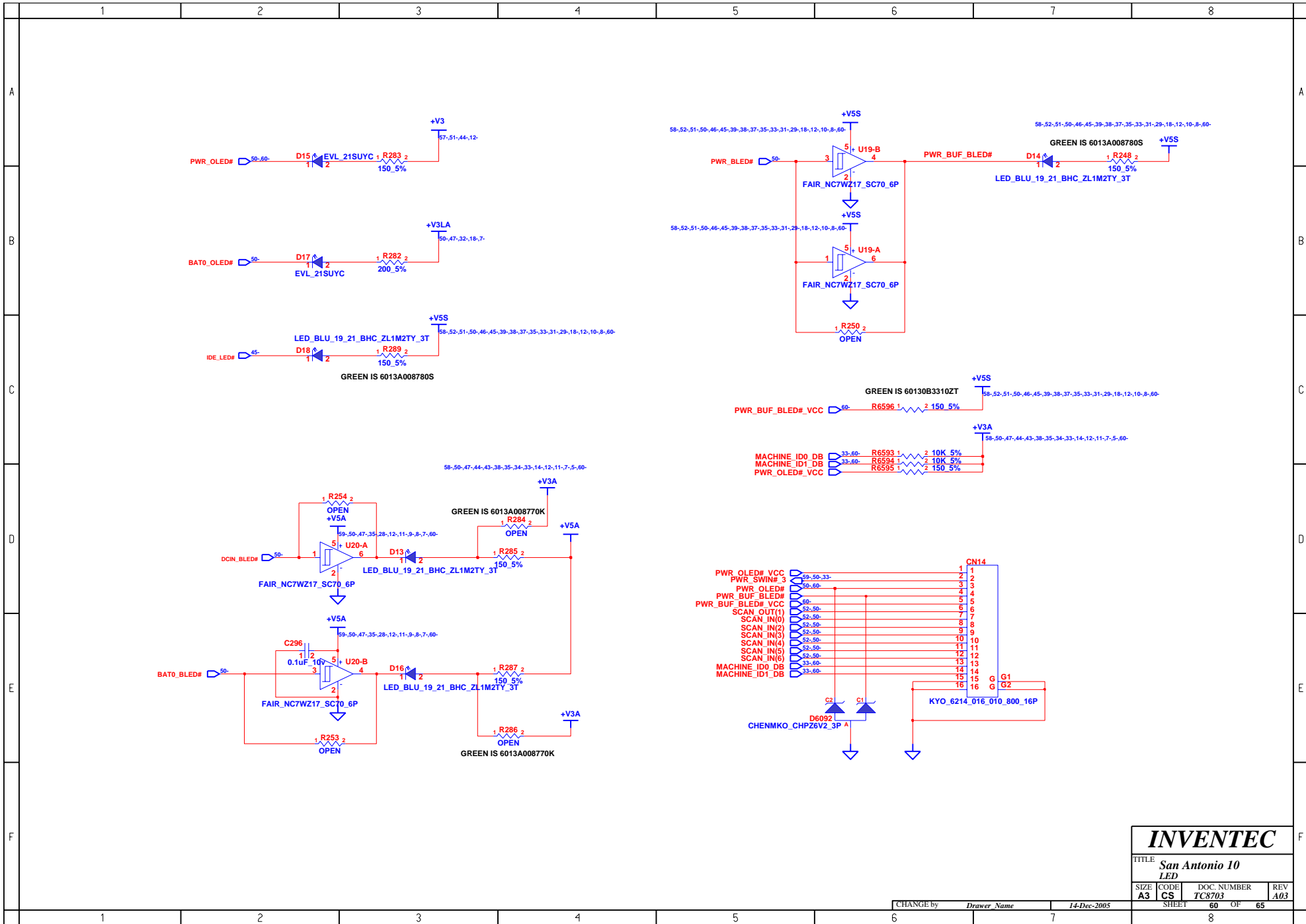

# INVENTEC

TITLE			
San Antonio 10			
LED			
SIZE	CODE	DOC. NUMBER	REV
A3	CS	TC8703	A03

CHANGE by *Drawer Name* 14-Dec-2005

SHEET 60 OF 65

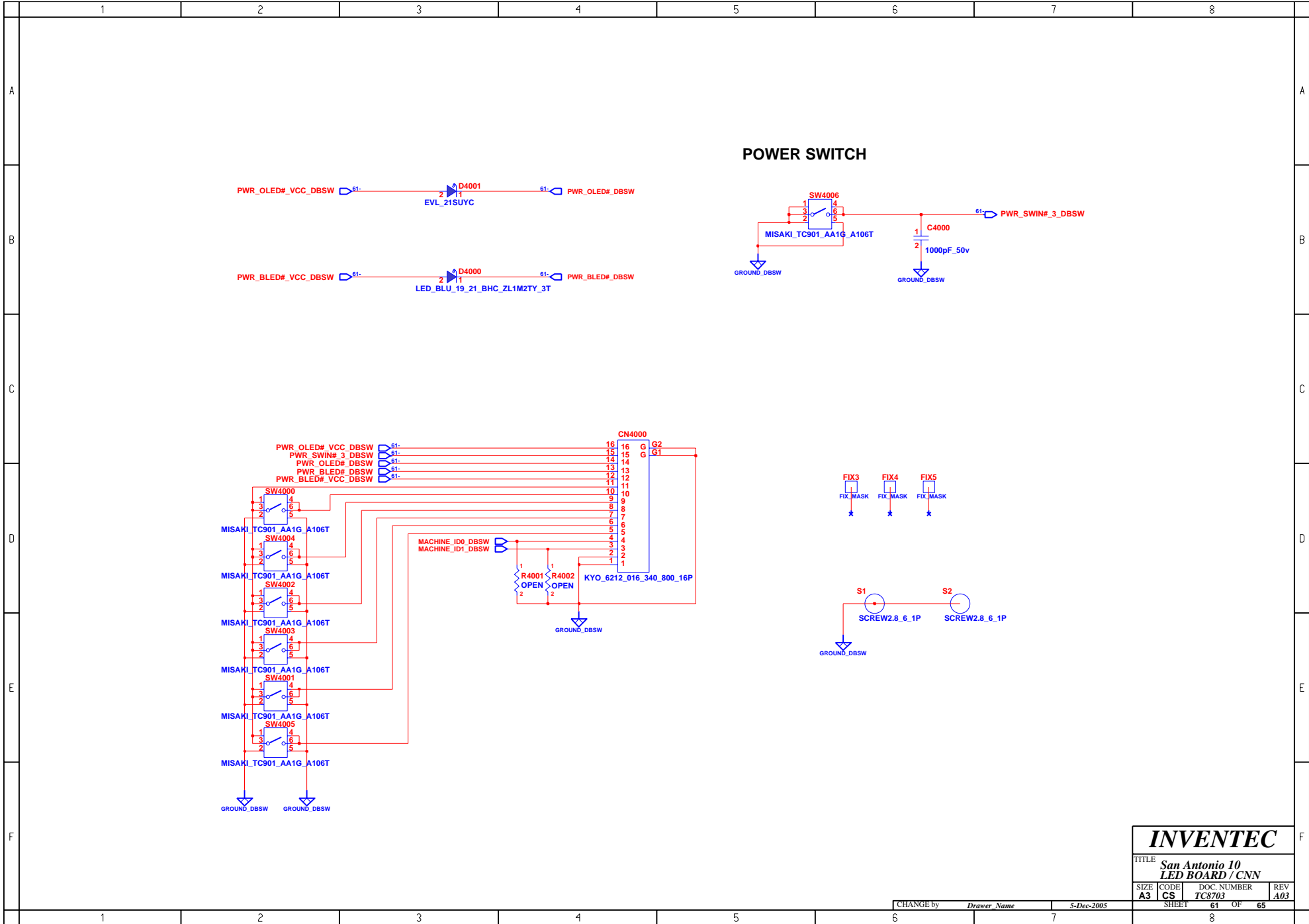

**POWER SWITCH**

**INVENTEC**

TITLE *San Antonio 10 LED BOARD / CNN*

SIZE <b>A3</b>	CODE <b>CS</b>	DOC. NUMBER <b>TC8703</b>	REV <b>A03</b>
-------------------	-------------------	------------------------------	-------------------

CHANGE by *Drawer Name* 5-Dec-2005

SHEET 61 OF 65

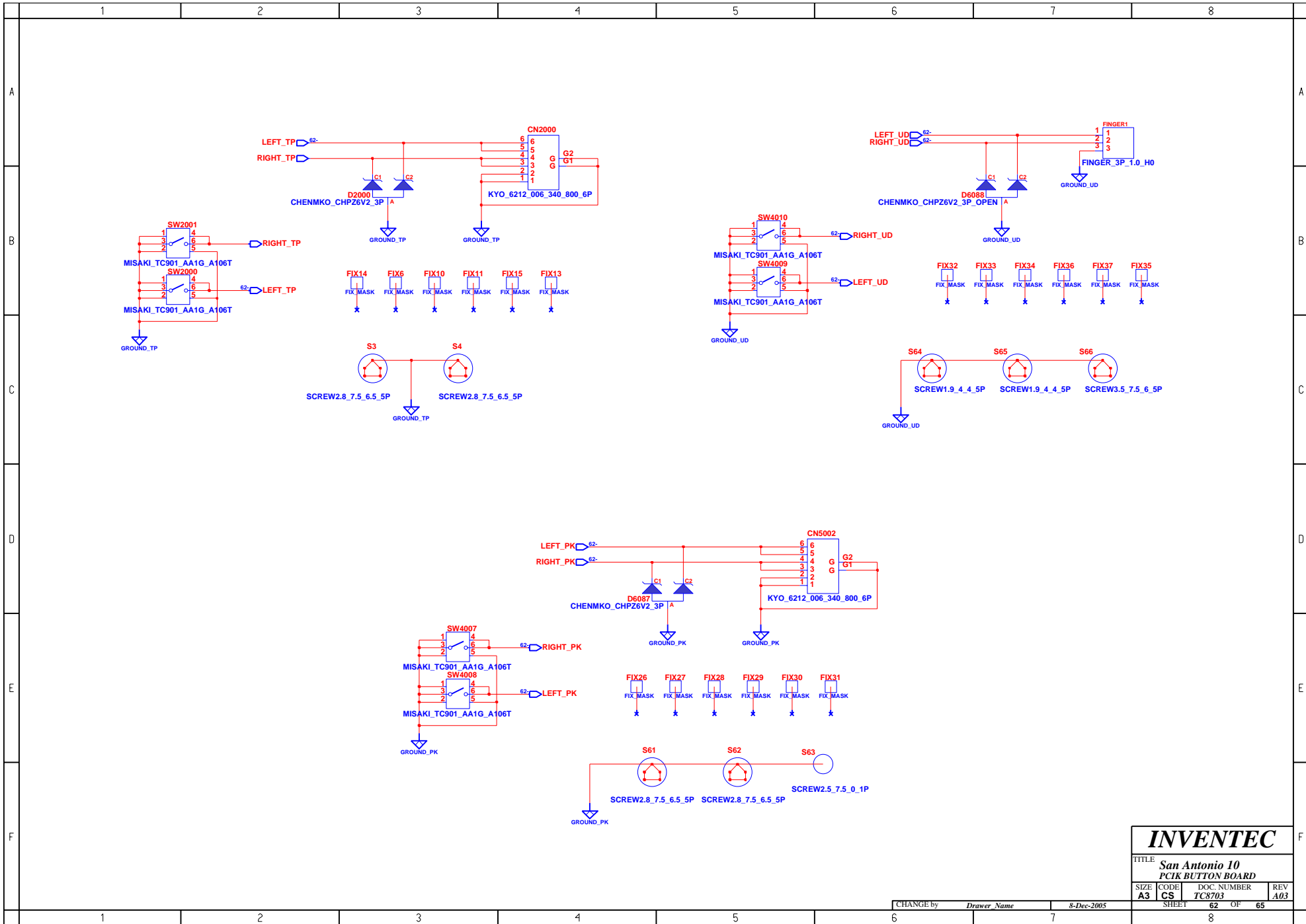

# INVENTEC

TITLE  
**San Antonio 10  
 PCIK BUTTON BOARD**

SIZE <b>A3</b>	CODE <b>CS</b>	DOC. NUMBER <b>TC8703</b>	REV <b>A03</b>
-------------------	-------------------	------------------------------	-------------------

CHANGE by *Drawer Name* 8-Dec-2005  
 SHEET 62 OF 65

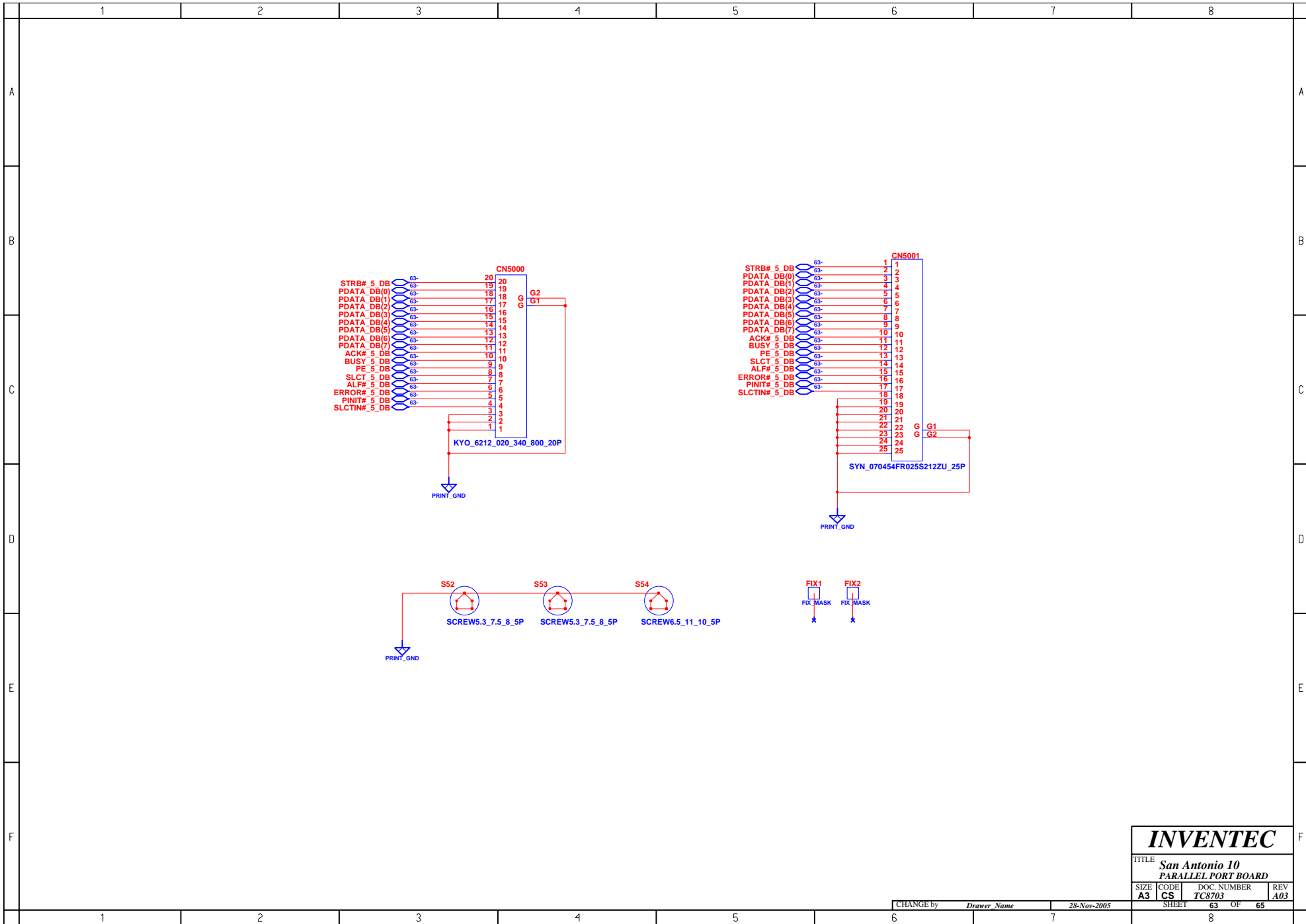

**INVENTEC**

TITLE **San Antonio 10  
PARALLEL PORT BOARD**

SIZE <b>A3</b>	CODE <b>CS</b>	DOC. NUMBER <b>TC8703</b>	REV <b>A03</b>
-------------------	-------------------	------------------------------	-------------------

CHANGE by *Drawer Name* 28-Nov-2005

SHEET 63 OF 65

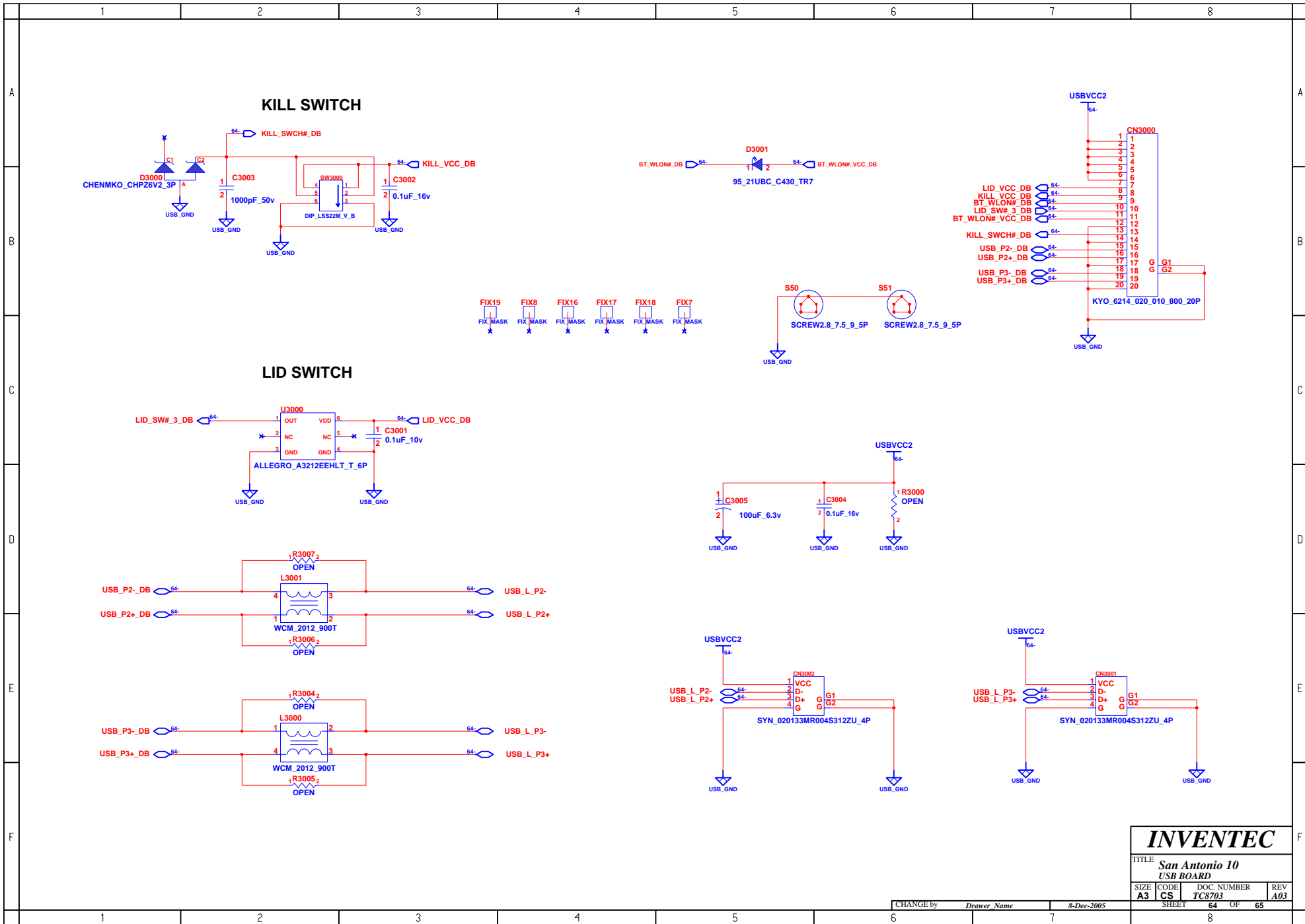

<b>INVENTEC</b>			
TITLE <b>San Antonio 10 USB BOARD</b>			
SIZE <b>A3</b>	CODE <b>CS</b>	DOC. NUMBER <b>TC8703</b>	REV <b>A03</b>
CHANGE by <i>Drawer Name</i>		8-Dec-2005	
SHEET <b>64</b>		OF <b>65</b>	



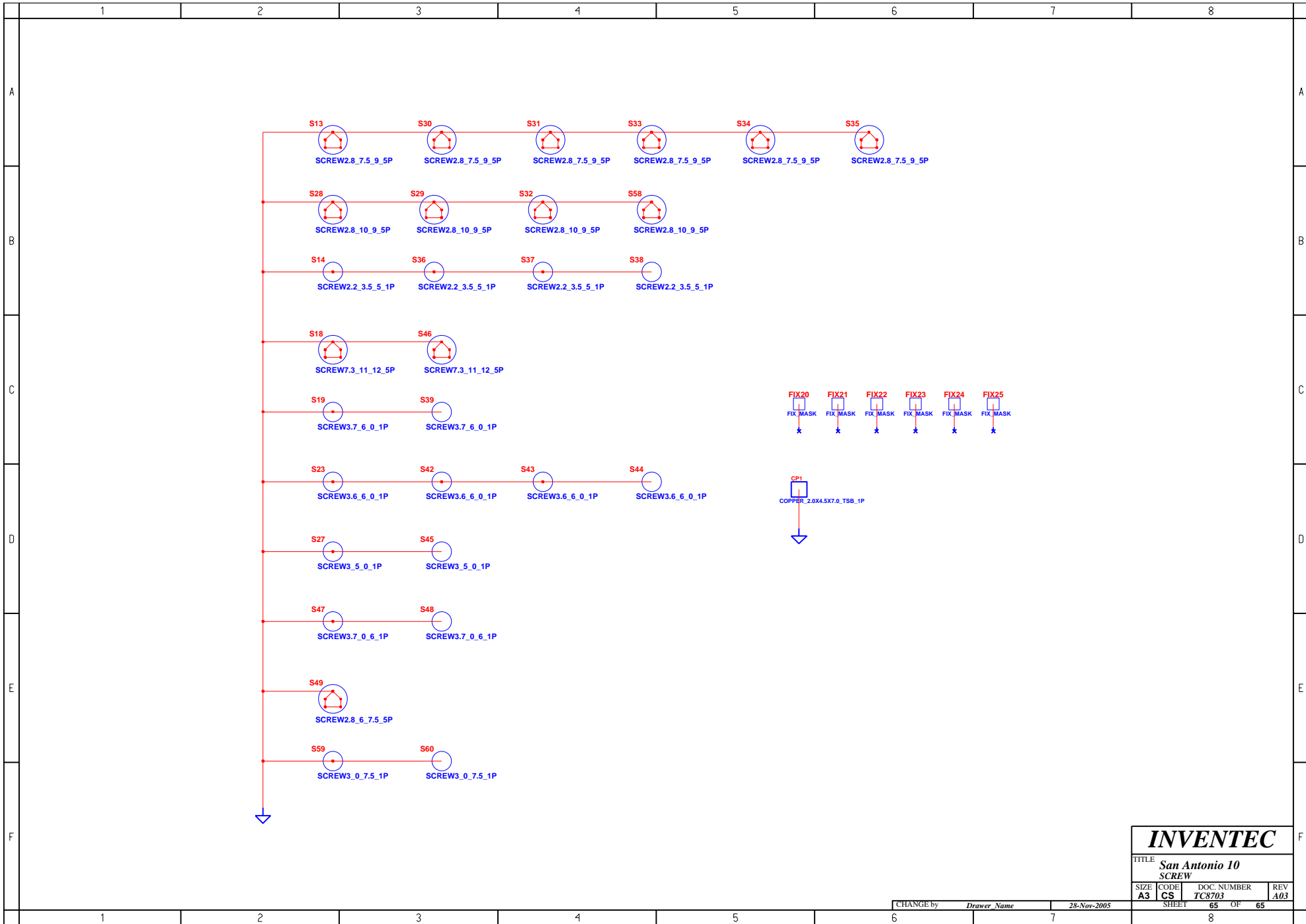

**INVENTEC**

TITLE **San Antonio 10  
SCREW**

SIZE <b>A3</b>	CODE <b>CS</b>	DOC. NUMBER <b>TC8703</b>	REV <b>A03</b>
-------------------	-------------------	------------------------------	-------------------

CHANGE by *Drawer Name* 28-Nov-2005

SHEET 65 OF 65